

Dynamic characterization of a heritage construction from 19th century

Caracterização dinâmica de uma edificação histórica do século XIX



F. BRANDÃO^a
eng.franciscobrandao@hotmail.com

E. MESQUITA^b
e.mesquita@fe.up.pt

A. DIÓGENES^a
aldeciragd@yahoo.com.br

P. ANTUNES^c
pantunes@ua.pt

H. VARUM^b
hvarum@fe.up.pt

Abstract

Heritage constructions presents high significance and importance for society. As way of contribution for the preservation of the heritage constructions, this paper presents a study on the dynamic behavior of a heritage construction, part of the historic center of Sobral city, located at the north region of Ceará State, namely the Nossa Senhora das Dores Church, a church from the beginning of the 19th century, built in clay brick walls. In this study, ambient vibration tests were performed aiming to obtainment of the natural frequencies of the building focusing the calibration of the numerical model and, from it, proceeding with modal analysis by Finite Element Method (FEM) with recurrence to software Ansys®. The results allowed the analysis of the structural dynamic behavior taking into account natural frequencies, modal shapes and directional displacements.

Keywords: dynamic characterization, heritage construction, environmental vibrational characterization, finite elements, sobral's historical heritage.

Resumo

As construções históricas possuem elevado significado e importância para a sociedade. Como contribuição à preservação do patrimônio histórico, o presente trabalho apresenta um estudo sobre o comportamento dinâmico de uma edificação histórica, inserida no âmbito do patrimônio histórico da cidade de Sobral, localizada na região norte do estado do Ceará, nomeadamente Igreja de Nossa Senhora das Dores, uma capela do início Século XIX, construída em alvenaria de tijolos maciços. Neste estudo foi realizado o ensaio de vibração ambiental com objetivo de obter as frequências naturais da edificação com foco à calibração do modelo numérico e, a partir dele, com recurso ao software Ansys®, realizar a caracterização modal via Método dos Elementos Finitos (MEF). Os resultados obtidos permitiram analisar o comportamento dinâmico da estrutura, no que se refere à obtenção das frequências naturais, modos de vibração e deslocamentos direcionais.

Palavras-chave: caracterização dinâmica, construções históricas, caracterização vibracional ambiental, elementos finitos, patrimônio histórico sobralense.

^a GEM, Department of Civil Engineering, State University of Vale Do Acaraú, Sobral, CE, Brazil;
^b CONSTRUCT-LESE, Department of Civil Engineering, Faculty of Engineering of the University of Porto, Porto, Portugal;
^c Telecommunications Institute and Department of Physics of the University of Aveiro, Aveiro, Portugal.

Received: 04 Aug 2016 • Accepted: 07 May 2017 • Available Online: 15 Feb 2018

 This is an open-access article distributed under the terms of the Creative Commons Attribution License

1. Introduction

Heritage constructions can be understood as structures with importance artistic, cultural, religious, documentary or aesthetics for a society. In other words, heritage constructions represent the cultural identity of a community.

Heritage constructions, as the other types of structures, are subject to several scenarios of degradation, among natural actions (thermal effects, chemical or physical attacks), anthropic actions, such as alterations in buildings architecture, interventions, and also dynamic actions such as wind and earthquakes. For that, and considering its high cultural value, this special class of structures need to be appropriately maintained as way to keep its structural safety conditions [1]. However, for efficient maintenance or retrofitting measures adoption, it is necessary to implement the current state of knowledge on structural characteristics and behavior of heritage constructions, once these structures may present different constructive methods and complex structural properties, such different from structures designed nowadays.

As highlighted by [2], exist a gap in the technical-scientific literature on structural characteristics of historical heritage and, considering the large interest on keep its structures in safety condition, as well considering its potential of contribution to regional tourism implementation, and also, by necessity to implement the current state-of-the-art in this field of engineering, it is evident that heritage constructions constitute topic of interest for scientific and technological development. Thus, studies essentially focused on non-destructive characterization of historical heritage have been recently developed by State University of Vale Do Acaraú, at Sobral, Brazil, with support by the Faculty of Engineering of the University of Porto and the University of Aveiro, in Portugal, in order of to contribute for field implementation, among some works can be seen in [3], [4], [5], [6].

To study the structural dynamic characteristics can be a fundamental step for structural behavior characterization, as well these information can be also used as support for implementation of monitoring systems, since dynamic properties are related with performance of the structural components and, consequently, with the structure integrity [7], [8] structural health monitoring is a fundamental tool to control the civil infrastructures lifetime. Raw earth masonry structures (as adobe, rammed earth, among other techniques. In the case of heritage constructions, the employment of dynamic characterization is relevant not only for the dynamic data collected, but because its non-destructive nature presents guarantees of repeatability without risk of to provoke damage emergence on assessed structure [9].

The employment of experimental methodologies for dynamic characterization, like the environmental vibration, can be an asserive tool in order of to provide accurate data to support the calibration of numerical models. Numerical simulations can also be employed with focus on obtaining the structural response to different damage scenarios and used as support tool for decision-making on maintenance and retrofitting measures [10].

This way, as contribution to the implementation of technical-scientific literature and, consequently, for the preservation of historical heritage, the present work proposes to study the dynamic characteristics of a heritage construction, namely, the Nossa Senhora das Dores Chuch, a chapel from the beginning of the 19th century placed in Sobral, built in solid bricks masonry.

2. Dynamic characterization of buildings

According to [11], dynamic actions can be characterized by the action of loads changing over time its magnitude, direction and point of application, and that can be characterized by the existence of oscillatory movement, designated by vibrations. Therefore, the structure response to these actions can be expressed in terms of displacements, speeds, acceleration or tensions. Essentially, the characterization of the dynamic behavior of the structures comprises the calculation of the natural frequencies, modal shape and also, the estimation of modal damping coefficients.

One of the strategies for dynamic properties characterization of a structure can be performed using *in situ* testing, collecting data on structure acceleration, where after the data be processed, dynamic parameters, such as natural frequencies and modal shapes, can be identified. These tests can be performed on new buildings and old buildings, such as in the case of heritage constructions that may require rehabilitation actions. Currently, for this type of characterization, the environmental vibration tests have been frequently employed (see [12], [13], [14], [15], [16]), due to the fact that they do not constitute an invasive technique, require less time, when compared with the traditional load tests.

According to [17], environmental vibration tests are based on the measurement of time series of acceleration at points in the structure previously chosen by simulating of the preliminary numerical model with initial mechanical properties. From these measurements, the modal parameters (natural frequencies, modal shapes and damping) are identified. In this type of test, the excitation force on the structure is the result of the environmental actions (wind or earthquake, for example) and operational actions (linked to the use of the structure), therefore, there are no control over excitation force.

The collection of structures acceleration data is usually performed using accelerometers. The piezoelectric accelerometers, for instance, employs materials able to generate a difference electrical potential when subjected to mechanical pressure. According to [18], piezoelectric accelerometers are essentially configured by an inertial mass positioned in contact with the surface of a piezoelectric material. When this accelerometer is subjected to a motion change, the inertial mass produces a mechanical stress in the piezoelectric material, and this, has as response an electric charge proportional to the applied voltage.

In terms of the processing of the data obtained by environmental vibration tests, these data can be processed by the application of consolidated methods, such as the application of Fast

Fourier Transform (FFT), described by Equation (1) that modifies the temporal function $f(t)$ in a function in the frequency domain $F(\omega)$, and which expresses the frequency content of $f(t)$. By the application of the FFT, the Fourier Spectrum is extracted, by which the dominant frequencies can be identified to the collected signal, and which indicate the natural frequencies of the structure [19].

$$F(\omega) = \int_{-\infty}^{\infty} f(t)e^{-i\omega t} dt \quad (1)$$

By itself, the results obtained by dynamic structural characterization through environmental vibration tests, provide a good understanding of the behavior of heritage constructions, but this approach can be complemented by a numerical simulation of the structure model using modal analysis using and the data obtained in the environmental vibration tests. In these cases, the numerical models are used to reproduce, the most closely possible, the dynamic behavior of the structure, according to the parameters collected during the environmental vibration tests. The numerical results (natural frequencies and modal shapes) are then compared to the values obtained experimentally, and by the adjustments in the properties of the model, particularly the modulus of elasticity, can guarantee similarity between the real behavior of the structure and the behavior of the numerical model. In this way, it's possible that the numerical model developed, is calibrated and it's used with confidence for the safety assessment of the structure in various risk scenarios [20].

For the modal analysis of a structure, considering it in a non-damped free vibration regime of linear behavior, the differential equation of motion has the following form:

$$M\ddot{u}(t) + Ku(t) = 0 \quad (2)$$

Where K represents the stiffness matrix of the structure, M represents the mass matrix of the structure, $u(t)$ represents the displacement and $\ddot{u}(t)$ represents the acceleration, of the structure. In considering that the structure presents a harmonic motion when it vibrates at a natural angular frequency ω_j , its displacement is expressed by:

$$u(t) = \hat{\varphi}_j \cos(\omega_j t - \theta_j) \quad (3)$$

Where $\hat{\varphi}_j$ is a vector named natural modal shape of the structure, ω_j is a magnitude named the natural frequency of vibration of the structure, and θ_j is the phase angle. Now, making the second-order derivative of Equation (2) with respect to time, gives the Equation (4), that represents the accelerations:

$$\ddot{u}(t) = -\omega_j^2 \hat{\varphi}_j \cos(\omega_j t - \theta_j) \quad (4)$$

Finally, substituting the Equations (3) and (4) into Equation (2) gets the following equation:

$$[K - \omega_j^2 M] \hat{\varphi}_j = 0 \quad (5)$$

From where are extracted ω_j^2 , that is an eigenvalue and square

of the j -th natural frequency, and $\hat{\varphi}_j$, that represents a j -th natural modal shape or non-damped mode. The Equation (5) expresses a generalized eigenvector problem and has nontrivial solutions $(\omega_j^2, \hat{\varphi}_j)$ only if the matrix of the coefficients $[K - \omega_j^2 M]$ is singular, that is:

$$\det[K - \omega_j^2 M] = 0 \quad (6)$$

With this, is possible to infer that for each solution of the eigenvalue ω_j^2 , there is an eigenvector corresponds $\hat{\varphi}_j$.

3. Case study

3.1 The Nossa Nossa Senhora das Dores's Church

The Nossa Senhora das Dores Church (Figure 1-A) is a heritage construction from historic center of the Sobral downtown, located near of Acaraú River (Figure 1-B). Sobral downtown is located in the north region of the Ceará State (Figure 1-D) over away 230 km from the capital of the State, Fortaleza. Sobral has one of the biggest Brazilian historical centers, including more than 1,200 buildings registered by the Instituto do Patrimônio Histórico e Artístico Nacional (IPHAN).

According to [11], the Nossa Senhora das Dores, dates from the decade of 1,810, and was built in the place where there was a set of old buildings located in the old Rua do Rio along the margins of the Acaraú River. It is not known when the church was built, but it is known that it already existed in 1,818. Its only and lateral tower does not follows the neoclassical rule of its elements of facades, because it was completed after 1,924. The Igreja das Dores was built in solid bricks masonry using local construction techniques. Its geometry (Figure 2) is characterized by one central nave of greater proportion (6.46x16.02m) and one lateral of smaller proportion (3.23x12.00m). In the same alignment of the central nave is located the altar, which is separated from this nave by one triumphal arch. After the altar there is a small sacristy and utilitarian dependencies of the Church. The access to the floor (choir) can be done by a staircase in the only lateral tower with 20.50 m of high.

In Figure 3- A is shown the interior of the building, where is possible to see in more details the lateral arches that separate the two nave, while the Figure 3-B shows the altar seen from the floor, where can be seen the low degree of ornamentation of this church.

3.2 Numerical simulation of Igreja das Dores

For the creation of the 3D model of the Nossa Senhora das Dores Church, was done a consultation of the building plans, provided by IPHAN-CE in CAD format. In addition, was done a visit to the church, that allowed the validation of the constant measures in the geometric registers. Based on these registers and the visit, a 3D model of the church was built using the AutoCAD® commercial software (Figure 4), where is possible to see that the wooden ceiling, the ceramic tile roof and the frontal façade, were not modeled, as a way to simplify



Figure 1
 (A) View of the Nossa Senhora das Dores's Church, (B) Location of said church in Sobral,
 (C) Location of the Ceará State in Brazil and (D) Location of the city of Sobral in the Ceará State

the model and also to minimize the occurrence of discontinuities, which would generate problems in the discretization of the finite element mesh.

The ornamental details of facades and doors were simplified, the walls were modeled with a constant thickness of 60 cm, except the highlighted walls in Figure 5, where the black rectangle indicates the wall behind the altar with a thickness of 35

cm, the yellow rectangle indicates the wall of the bathroom door with a thickness of 15 cm and the red rectangle indicates the walls of the lateral tower that was modeled with a thickness of 105 cm. These measurements were obtained according to the existing geometric records and confirmed in the *in situ* inspection that was performed.

The mechanical properties adopted of the masonry of numerical

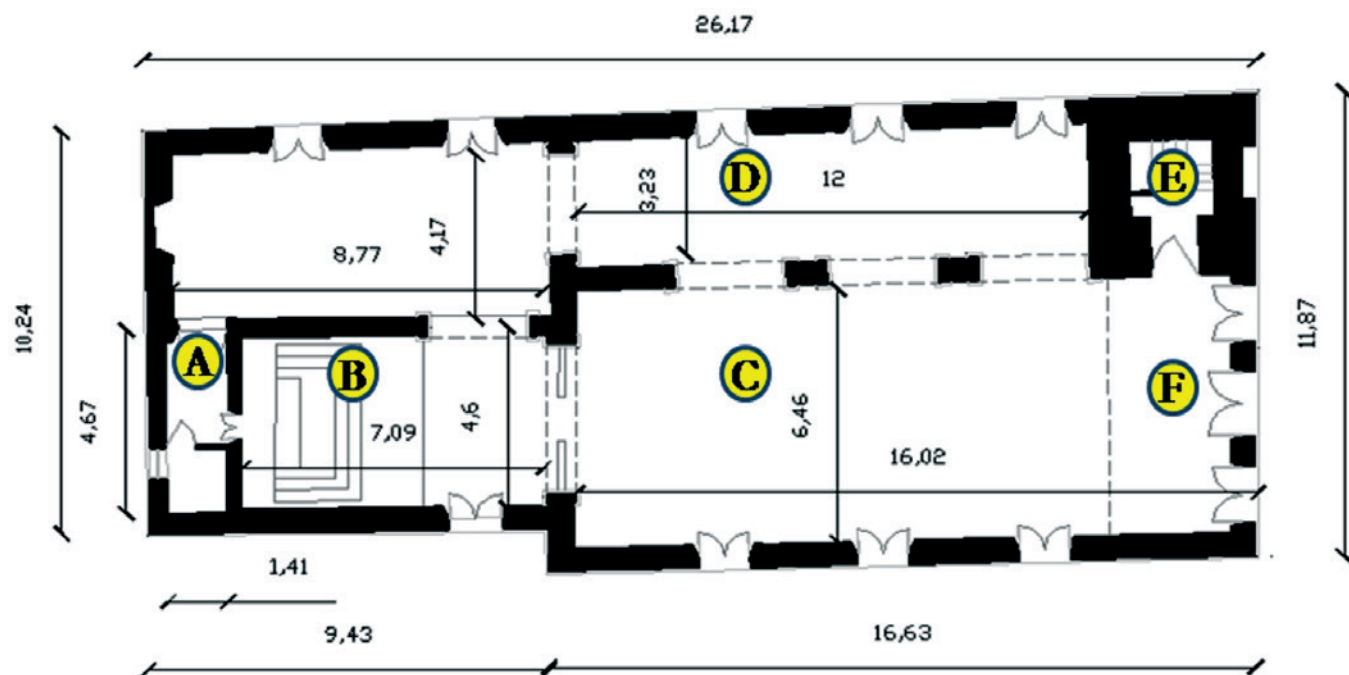

Figure 2
 Geometry of the Nossa Senhora das Dores's Church: (A) Sacristy; (B) Altar; (C) Central nave;
 (D) Lateral nave; (E) Lateral tower and (F) Floor [22, Adapted]



Figure 3
Interior of the Igreja das Dores: (A) view of the arches and (B) view of the altar

model was obtained on the existing literature in the field. Was decided to use the data on the Modulus of Elasticity (E), Specific Weight (W) and Compression Strength (f_c), of the Italian Regulation “*Norme Tecniche per le Costruzioni (NTC)*” of 2008 [23]. It should be noted that some Italian entities have even developed specialized calculation and analysis programs for masonry structures, such as 3DMacro and 3Muri, which use the NTC values for the elaboration of calculation models. The coefficient of Poisson (ν), was considered 0.2, value this is commonly adopted in studies in this field, as [24], [25], [26]. However, the tensile strength value of the masonry, (f_t), which is considered null in many calculation programs as 3muri, was considered 5% of the value adopted for the compressive strength (f_c). It should be noted that these values were obtained

through extensive bibliographical research, and are in accordance with the structural typology of the edification of the present study. The mechanical properties inserted in the model are shown in Table 1.

In the discretization of the numerical model in finite elements developed in the program Ansys® (version 17.1), was used a mesh of 500 mm side, it was generated 53,889 elements and 93,380 nodes. The element chosen was SOLID187, a tetrahedral element of 10 nodes with 3 degrees of freedom in each. This type of element is very flexible and compatible with irregular meshes and allows that curvilinear surfaces, arches, doors and windows, to be modeled more precisely without geometry losses. The Figure 6 shows the finite element mesh used.

3.3 Ambient vibration test

The obtaining of the experimental data related to modal properties of the Nossa Senhora das Dores’s Church was performed using the environmental vibration test that was executed on 04/28/2016 in the afternoon from 14:00h to 17:00h. However,

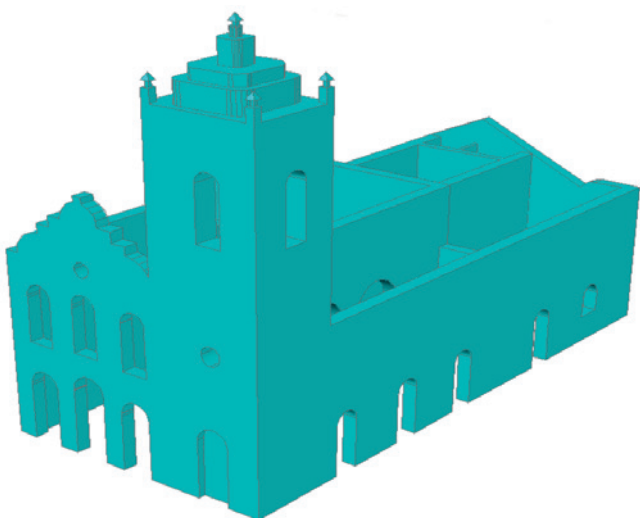

Figure 4
3D model of the Nossa Senhora das Dores's Church

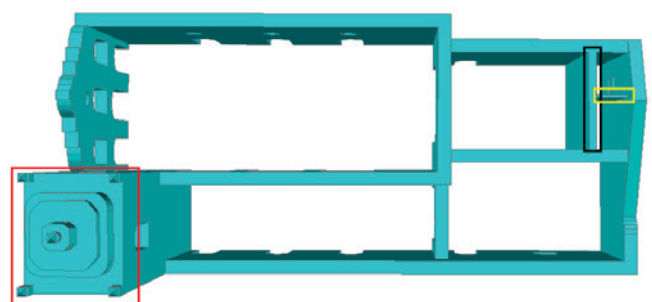

Figure 5
Details of wall thicknesses adopted in 3D Model of das Dores's Church

Table 1

Mechanical properties adopted in the numerical model

E (GPa)	W (kN/m ³)	f _m (MPa)	f _t (MPa)	v
1.5	18	3.2	0.16	0.2

before carrying out the experimental test, was performed a preliminary modal analysis of the model using the mechanical properties of the masonry indicates in Table 1, in order to obtain a first approximation of the values of the natural frequencies and the modal shapes of the structure and to identify the zones with the high displacements observed in the first modal shapes and more, in these zones, to position the accelerometers.

The equipment used in this test was a triaxial accelerometer of the piezoelectric type, with sampling frequency between 0 Hz and 100 Hz, configurable through a software developed in Labview by the Instituto de Telecomunicações de Aveiro, Portugal. The points where the accelerometer was positioned are indicated in Figure 7.

The accelerometer was fixed a time at each one of the three points and the data collection lasted 10 minutes. The accelerations were collected in the 3 axes (X, Y and Z), where the X axis was considered outside the plane of the walls, the Y axis in the plane of the walls and the Z axis in the vertical position.

3.4 Experimental identification of natural frequencies

The accelerograms collected in the test (Figure 8 and Figure 9)

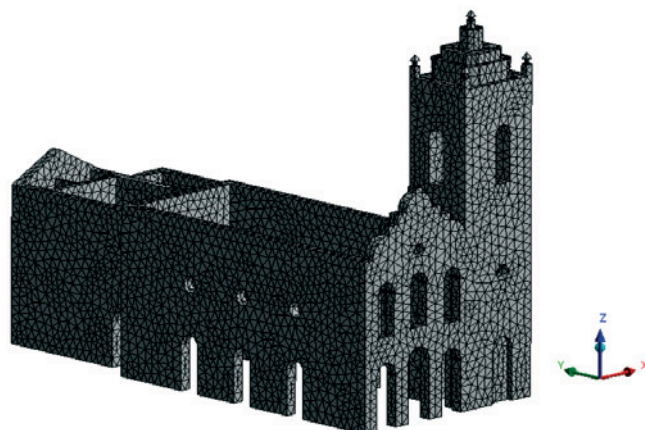

Figure 6
Finite element mesh used in the model

were processed using the Fast Fourier Transform (TRF), using 16,384 points, since the TRF requires samples whose size is the entire power of 2, in this case $2^{14} = 16,384$. The points were spaced at 0.001 s time intervals, which totaled 16.384 s of signal and the noise effects on the frequency signals were filtered with *SeismoSignal*[®] software.

From the accelerograms collected, were considered only the referring to the X axis and the Y axis, since the X axis refers to off-plane displacements of the walls and the Y axis in the plane of the walls in the longitudinal direction, and also because in the Z axis, the preliminary modal analysis of the model, finds very low displacements in relation the displacements in the other

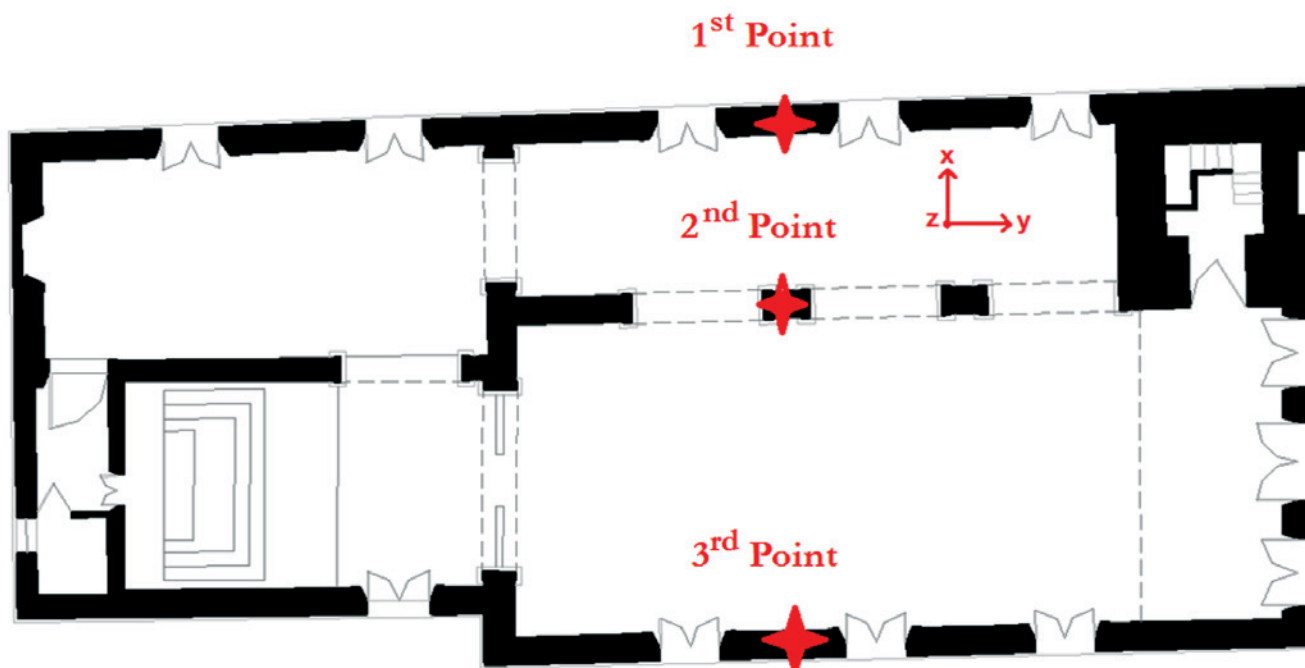

Figure 7
Location of the points of the building that was chosen for the environmental vibration test

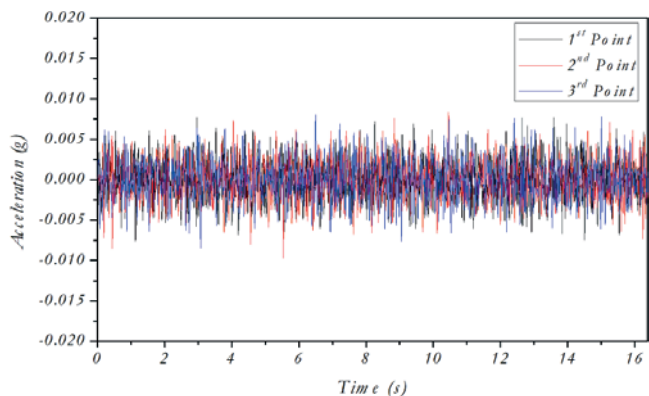

Figure 8
Accelerogram of 3 points on the X axis

axes (X and Y), in addition, the structure does not have pavements, so, there is no expressive participation of effective modal mass in the Z axis, that would lead to an increase in frequency. Applying the TRF to the accelerograms in X and Y axis, was possible to obtain the Fourier spectra in these two directions. Still in the preliminary modal analysis of the model, no frequencies lower than 1.50 Hz were found, therefore, for the building in study, a filter Lowpass and Bandpass from 1.00 Hz to 30.00 Hz was applied to the Fourier spectra to eliminate the external frequencies at this interval. It is further emphasized that the amplitude of the frequencies comprised between 0 Hz and 1.00 Hz before the application of the filter, were not greater than 0.01 Hz reason why the application of the filter is justified. With the application of the filter to the calculated Fourier spectra, the results obtained are shown in Figure 10, for the X direction and in Figure 11, for the Y direction. Is shown only the frequency range on the horizontal axis between 1 Hz and 7 Hz for a better visualization of the maximum amplitudes of each frequency and also because, the first three frequencies identified for the building are within this range, as indicated in the figures. By analyzing of the these two spectra, it can be inferred that the first 3 natural frequencies of the building are between 2.00 Hz and 4.00 Hz. Considering the frequencies with the highest

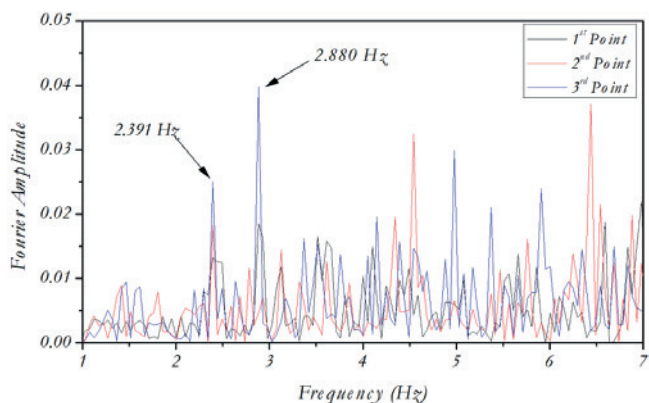

Figure 10
Fourier spectra in the X axis for the three points tested

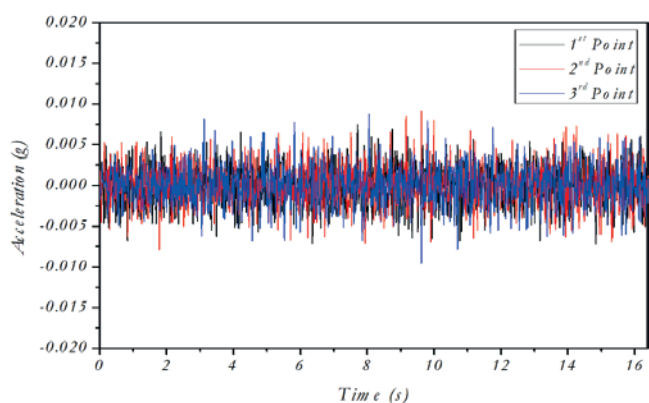

Figure 9
Accelerogram of 3 points on the Y axis

values of amplitude in relation to each axis, the first fundamental frequency of the building is 2.391 Hz in relation to the X axis, the second is 2.880 Hz also in the X direction, since the amplitude of the first two peaks in the X direction is greater than in the Y direction. The third natural frequency was obtained on the Y axis in the third peak of the spectrum of the Figure 11, whose value is 3.125 Hz, because in this direction its amplitude much larger than the third peak of the spectrum of Figure 10. The values of the first three natural frequencies of the das Dore's Church are indicates in Table 2. Only the first three natural frequencies of the das Dore's Church are identified, because these were considered sufficient for the calibration of the model in finite elements, in addition, the most important of all is the first, because it has the longest period.

3.5 Calibration of the model

The calibration of the numerical model was done using the natural frequencies obtained in the experimental test, keeping the specific weight constant and adjusting only the modulus of elasticity adopted for the masonry, having as limit the maximum value imposed by the Italian technical norm, 1.8 GPa . The modulus of elasticity was adjusted in the Ansys® program to

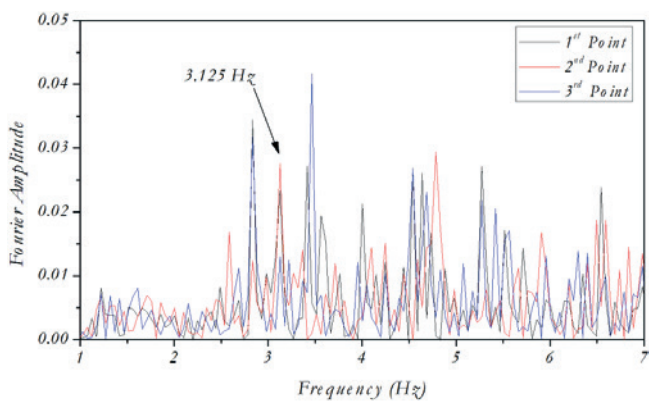

Figure 11
Fourier spectra in the Y axis for the three points tested

Table 2

First 3 natural frequencies of the das Dores's Church

Mode	Frequency (Hz)
1	2.391
2	2.880
3	3.125

that the natural frequency of the first modal shape of the model arrived as close as possible to the value obtained in the experimental test, and the other frequencies, of the second and third modes, would be adjusted by the first frequency. The modulus of elasticity of 1.50 GPa, the first value used, was varied to 1.75GPa, to that the values of the frequencies obtained by the numerical simulation presented values close to the experimental values. The closest value of the natural frequency of the first mode of vibration was obtained by adjusting the modulus of elasticity to $E = 1.70$ GPa. The results, as well as the error associated with each of the frequencies, are shown in Table 3.

The differences between the dynamic parameters obtained numerically and those obtained by the experimental test, may be related to the structural modeling process and to the mechanical properties adopted. Is common practice to correct these models to use information obtained from ambient vibration tests, were the natural frequencies can be used for the correction of the elastic properties and inertia of the numerical model, and incorporate the damping characteristics obtained experimentally [27].

An error of up to 5% is acceptable, and in this calibration, the largest error value obtained from the difference between the natural frequency of the structure extracted by ambient vibration test and the natural frequency extracted by numerical analysis, was 2.637 %, which is well below this value. The mechanical properties adopted in the numerical model, now calibrated, are shown in Table 4.

From the mechanical properties of Table 4 inserted in the model, the natural frequencies were obtained for the first 20 modal shape of the building, with respective percentages of mass participation in each mode.

4. Results and discussions

From the modal analysis of the numerical model of the Nossa

Table 3

Comparative between the experimental and numerical frequencies of the building

Mode	Experimental frequency (Hz)	Ansys frequency (Hz)	Error (%)
1	2.391	2.403	0.502
2	2.880	2.806	2.637
3	3.125	3.084	1.329

Senhora das Dores's Church, were extracted the first 20 vibration modes, considering the linear-elastic regime of the materials. The natural frequencies, periods and percentages of participation of the masses for each of these 20 modes, are indicated in Table 5.

The percentage of mass participation for the first 20 modes of vibration in the X, Y and Z directions are respectively; 72.930%, 61.675% and 0.151%. Is observed that the X direction presents the higher percentage of mass participation, which causes high displacements in this axis, which can be confirmed through the first natural frequency, which was also identified in the direction of the said axis.

The Y direction also shows significant mass participation, more than 50% of the total mass of the church. The direction Z is the direction that presented the lowest percentages of modal participation, which indicates a tendency to obtain values of very low displacements in this axis, almost null. And it is precisely what is observed in Figure 12, where all the values of the directional displacements in each of the three axes are indicated.

The displacements shown in the negative direction of the horizontal axis indicate that the structure has moved in the negative direction of the reference axis system adopted in the analysis. The most expressive directional displacements are in the X direction, while the least expressive are found in the Z direction.

The first three modal shapes of the building are shown in Figure 13, where can be seen that the first mode is a local mode and presents flexion of the lateral left wall, that is the part of the structure that presents the biggest value of modal deformation, 0.215 mm, indicated by the red color of this figure. The second and third modal shapes are also flexion modes in the X direction, were in the second mode it is observed that the biggest modal displacement occurs at the top of the lateral tower; 0.108 mm. In the third mode, the biggest modal displacement occurs in the arcs that separate the two nave, which is 0.133 mm.

In Figure 14, are indicated the modal shapes that excite the major number of parts of the building, that is the global modes, were the 6th Mode and the 13th Mode, are flexion modes while that the 18th Mode is a torsion mode, that can be observed in the lateral tower.

Analyzing the Figures 13 and 14, can be inferred that the lateral left wall and the region of the central arcs, are the zones of the edification that are most requested in the modal shapes. For the lateral left wall, this fact may be related to non-continuity of the same, as it can be observed in the Figure 2, as this, a local modal shape was generated resulting in large modal

Table 4

Mechanical properties adopted in the calibrated numerical model

E (GPa)	W (kN/m ³)	f _m (MPa)	f _t (MPa)	v
1.70	18.00	3.20	0.16	0.20

Table 5
Results of the modal analysis

Mode	Frequency	Period	Mass participation		
	f (Hz)	T (s)	m _x (%)	m _y (%)	m _z (%)
1	2.403	0.416	13.533	0.219	0.000
2	2.806	0.356	20.969	3.020	0.003
3	3.084	0.324	7.241	16.007	0.010
4	3.342	0.299	0.022	4.951	0.008
5	3.796	0.263	3.031	0.008	0.000
6	4.925	0.203	3.571	0.211	0.000
7	5.547	0.180	7.051	2.271	0.001
8	6.229	0.161	0.581	2.311	0.001
9	6.753	0.148	0.628	0.558	0.001
10	7.247	0.138	0.019	4.143	0.003
11	7.867	0.127	3.864	0.147	0.000
12	8.192	0.122	0.993	0.013	0.001
13	8.591	0.116	1.437	0.212	0.000
14	8.763	0.114	0.943	0.729	0.003
15	8.924	0.112	0.950	0.001	0.001
16	9.275	0.108	0.720	4.703	0.001
17	9.463	0.106	1.851	13.502	0.049
18	9.907	0.101	0.526	8.546	0.026
19	10.341	0.097	4.412	0.062	0.027
20	10.835	0.092	0.588	0.060	0.017

displacements. For the region of the arches, this behavior was already expected, because generally in the region, for this type of buildings, these zones are very propitious to the appearance of fissures, due to tensions or to elevated displacements. The results obtained in this work are useful for the structural

monitoring of the building, because indicated the zones where accelerometers and displacement sensors can be installed, in addition, they make possible the comprehension of the global behavior of the structure and verification of the regions which, in the necessity of a retrofiting plan must be prioritized. This work has generated information that may be useful in simulations of various damage scenarios, such as the incidence of earthquakes, and can be used as a tool to support the structural safety of the Nossa Senhora das Dores's Church.

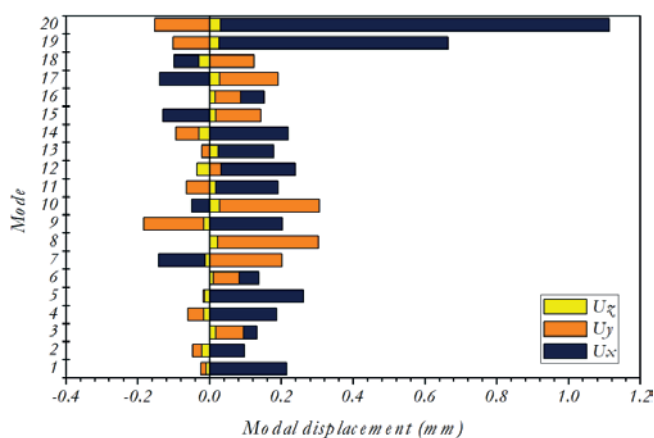

Figure 12
Comparison between the modal directional displacements of each mode

5. Conclusions

The Nossa Senhoras das Dores's Chcuch is an important heritage construction form the historic center of Sobral, in this work was defined a numerical model that represents this structure of the best way possible, in order to guarantee precision in the results of the modal analysis. By the ambient vibration test, it was possible to identify the first three natural frequencies of the building, necessary for the calibration of the numerical model, for to study the dynamic behavior by the modal analysis using the Finite Element Method.

The first three natural frequencies of the building are indentified in the range of 2.00 Hz to 4.00Hz, the first being 2.403 Hz, that differs 0.502% from the value obtained experimentally

(2.391 Hz). Was verified that the biggest displacements of the building, occur in the X direction, the axis with major participation of effective modal mass. The smallest displacements, occur in the Z direction, axis with more low mass participation. The first modal shapes of the building, were characterized by being

modes of flexion, among which some are local modes. From the sixth, the modes are global, being that, the 18th mode is characterized by twisting mode. Was also observed that, the region of the central arches is a much sought after zone, because its deformations are show in almost all the 20 modal shapes

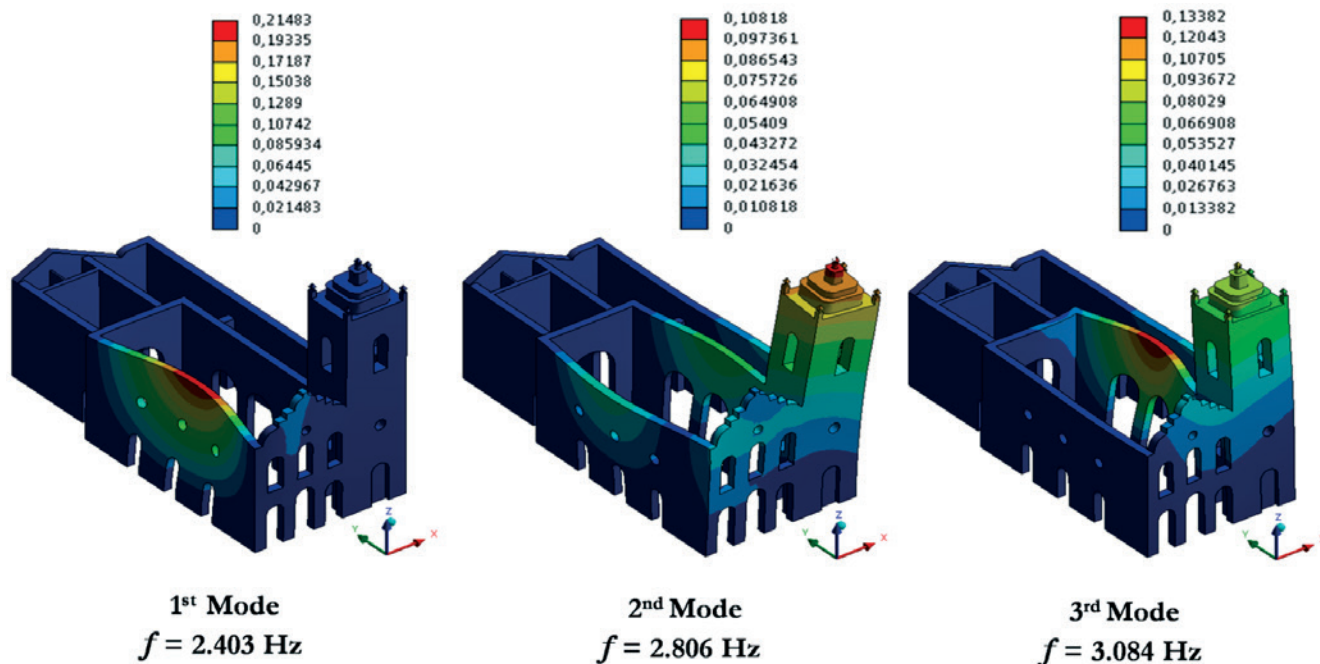

Figure 13
Three first modal shapes of the das Dores's Church

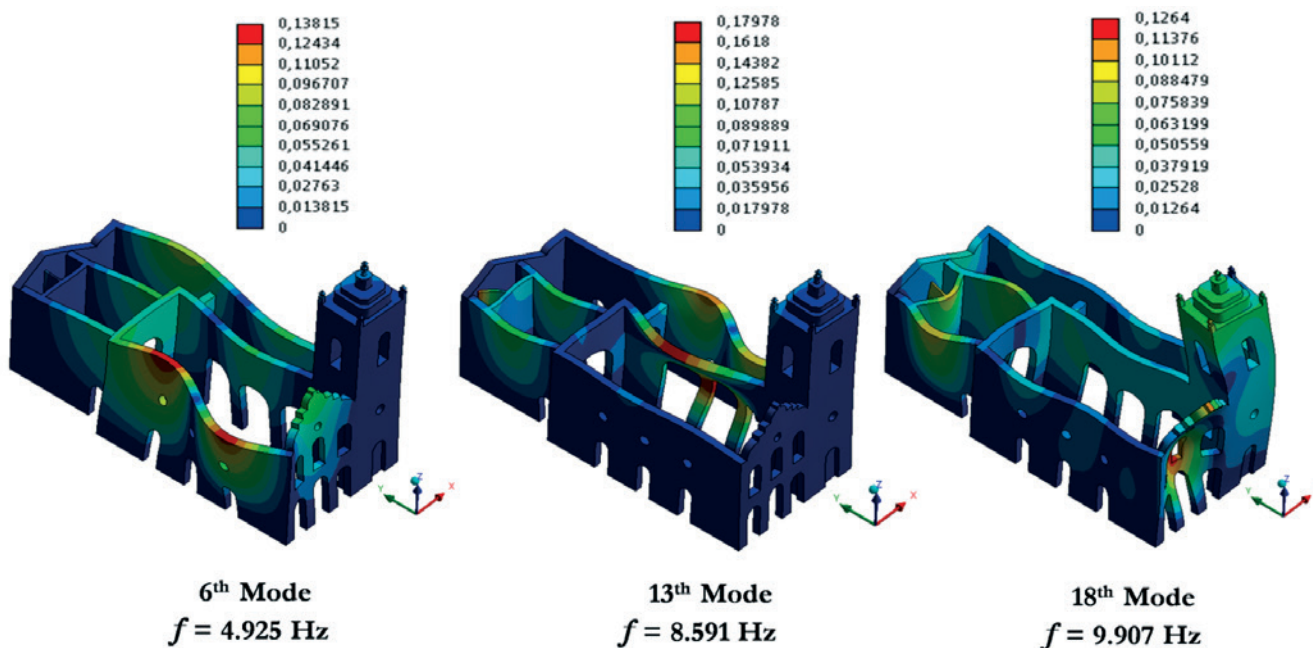

Figure 14
Modal shapes with larger parts of the building excited

extracted, and still, in many of these, it presents values of considerable displacements, mainly due to its geometry which directly influences its rigidity properties. In this way it can be inferred that this zone is one of the most propitious to the appearance of fissures.

This type of study, applied to heritage constructions, contribute to the implementation of knowledge about the global behavior and vulnerability of these structures, constituting important tools to support decision making on interventions focused on the preservation and maintenance of structural safety and valorization of the heritage.

6. Acknowledgments

The authors acknowledge the Instituto do Patrimônio Histórico e Artístico Nacional (IPHAN), for the files and information granted, to the Paróquia de Nossa Senhora da Conceição in Sobral for the support during the realization of the experimental tests and useful informations for development of this work. Francisco Brandão acknowledges the Acaraú Valley State University by the research fellowship of the PIC/PBU/UVA program and Esequiel Mesquita acknowledges the CAPES Foundation, Brazilian Ministry of Education for the full doctorate fellowship number 10023/13-5.

7. References

- [1] Roca, P. et al. Structural Analysis of Masonry Historical Constructions. Classical and Advanced Approaches. Archives of Computational Methods in Engineering, v. 17, n. 3, 2010; p. 299–325.
- [2] Mesquita, E. et al. Structural reliability assessment based on optical monitoring system: case study. IBRACON Structures and Materials Journal, v. 9, n.2, 2016;p. 297–305.
- [3] Alves, A. et al. Estimativa do módulo de elasticidade global de uma edificação histórica de alvenaria de tijolos maciços pelo método ultrassônico. In: Congresso Brasileiro de Patologia das Construções-CBPAT 2016, 2º, Belém, 2016, Anais, Belém, p. 1005-1015.
- [4] Cavalcante, A. et al. Caracterização dos danos em construções históricas de alvenaria vernacular: casos de estudo. In: Congresso Brasileiro de Patologia das Construções-CBPAT 2016, 2º, Belém, 2016, Anais, Belém, p. 757-765.
- [5] Mota, L. et al. Avaliação da vulnerabilidade sísmica à escala urbana: o centro histórico sobralense. In: Congresso Brasileiro de Patologia das Construções-CBPAT 2016, 2º, Belém, 2016, Anais, Belém, p. 559-569.
- [6] SANTOS, F. et al. Análise estrutural de uma edificação histórica do século XVIII. In: Congresso Brasileiro de Patologia das Construções- CBPAT 2016, 2º, Belém, 2016, Anais, Belém, p. 317-327.
- [7] Antunes, P. et al. Optical fiber sensors for static and dynamic health monitoring of civil engineering infrastructures: Abode wall case study. Measurement, v. 45, n.7, 2012; p.1695–1705.
- [8] Mesquita, E. et al. (2016). Global overview on advances in structural health monitoring platforms. Journal of Civil Structural Health Monitoring, v. 6, n.3, 2016; p. 461–475.
- [9] Boscato, G. et al. Optimized procedures and strategies for the dynamic monitoring of historical structures. Journal of Civil Structural Health Monitoring, v. 6, n. 2, 2016; p. 265–289.
- [10] Di Paola, M. et al. L'identificazione dinamica delle caratteristiche modali e meccaniche della struttura della cupola del Teatro Massimo. Meccanica dei Materiali e delle Strutture, v.3, n.2, 2012; p.94-107.
- [11] CARVALHO, A. F. C. Estudo numérico e experimental sobre o comportamento dinâmico de um edifício, Lisboa, 2013, Dissertação (Mestrado em Engenharia Civil/Estruturas)- Instituto Superior de Engenharia de Lisboa, 111 p.
- [12] Brownjohn, J. M. W. et al. Ambient vibration re-testing and operational modal analysis of the Humber Bridge. Engineering Structures, v. 32, n. 8, 2010; p. 2003–2018.
- [13] Magalhães, F. (2010). Operational modal analysis for testing and monitoring of bridges and special structures. Faculty of Engineering of University of Porto.
- [14] Martínez, G. et al. Determinación experimental y analítica de las propiedades dinámicas para la Catedral de Mallorca. Intersections/Intersección- Structural Engineering, v. 4, n. 2, 2007; p. 65-74.
- [15] Rinaldis, D.; Clemente, P.; Buffarini, G. Dynamic Behavior of a Historical Building. Advanced Materials Research, Vols. 133-134, 2010; p. 659-664.
- [16] Ceroni, F. et al. SSI on the Dynamic Behaviour of a Historical Masonry Building: Experimental versus Numerical Results. Buildings, v. 4, n. 3, 2012; p. 978-1000.
- [17] RODRIGUES, J. Identificação Modal Estocástica- Métodos de análise e aplicações em estruturas de Engenharia Civil, Porto, 2004, Tese (Doutorado em Engenharia Civil)- Faculdade de Engenharia, Universidade do Porto, 484 p.
- [18] RODRIGUES, J. R. et al. Identificação das principais componentes de incertezas de calibração de acelerômetro piezoelétrico pelo método da comparação: Uma revisão atual. In: VI Simpósio Brasileiro de Engenharia Inercial, 6º, Rio de Janeiro, 2010, Anais, Rio de Janeiro, p.1-7.
- [19] Grose, J; Sawicki, W.; Wójcicki, Z. Vibration measurements in analysis of historical structures Pomiary i analizy drgań obiektów historycznych. Wiadomości Konserwatorskie- Journal of Heritage Conservation , 32, 2012; p. 157-154.
- [20] Lopes, V. et al. Identificação dinâmica de estruturas. In: Congresso Património, Porto, 2010, Anais, Porto, p.1-21.
- [21] PINTO, J. J. de S. Os novos palácios da velha princesa: Intervenções arquitetônicas contemporâneas no sítio histórico de Sobral, Natal, 2009, Dissertação (Mestrado em Arquitetura e Urbanismo), Universidade Federal do Rio Grande do Norte, 129 p.
- [22] INSTITUTO DO PATRIMÔNIO HISTÓRICO E ARTÍSTICO NACIONAL (IPHAN). Inventário Nacional de Bens Arquitetônicos – IBA Sobral, 2005.
- [23] MINISTERO DELLE INFRASTRUTTURE E DEI TRASPORTI. Norme Tecniche per le Costruzioni (NTC 2008) D.M. del 14/01/2008. Roma, 2008.
- [24] BRANCO, M. E. M. Reforço Sísmico de Edifícios de Alvenaria- Aplicação a edifícios "Gaioleiros", 2007, Dissertação (Mestrado em Engenharia Civil), Instituto Superior Técnico, 98 p.

- [25] DELGADO, J. L. Avaliação sísmica de um edifício crítico em alvenaria. 2013, Lisboa, Dissertação (Mestrado em Engenharia Civil), Instituto Superior Técnico de Lisboa, 122 p.
- [26] FRAZÃO, M. T. de B. R. F. Modelação de um edifício “Gaioleiro” para Avaliação e Reforço Sísmico. 2013, Lisboa, Dissertação (Mestrado em Engenharia Civil), Instituto Superior Técnico de Lisboa, 117 p.
- [27] Simón, G. W. E. Identificación de modos cercanos de vibración de una estructura cuasi-axisimétrica: estudio complementario. Ingeniería Investigación y Tecnología, v. XIV, n.2), 2013; p. 207-222.