



FEDERAL UNIVERSITY OF CEARÁ  
DEPARTMENT OF TELEINFORMATICS ENGINEERING  
POST-GRADUATE PROGRAM IN TELEINFORMATICS ENGINEERING

CARLOS FILIPE MOREIRA E SILVA

CONTEMPORARY ELECTROMAGNETIC SPECTRUM REUSE TECHNIQUES:  
TV WHITE SPACES AND D<sub>2</sub>D COMMUNICATIONS

DOCTOR OF PHILOSOPHY THESIS

**SUPERVISOR:** PROF. DR. FRANCISCO RODRIGO PORTO CAVALCANTI  
**CO-SUPERVISOR:** PROF. DR. TARCISIO FERREIRA MACIEL

FORTALEZA/CEARÁ

DECEMBER 2015

CARLOS FILIPE MOREIRA E SILVA

TÉCNICAS CONTEMPORÂNEAS DE REUSO DO ESPECTRO  
ELECTROMAGNÉTICO: TV *WHITE SPACES* E COMUNICAÇÕES D2D

Tese apresentada à Coordenação do Programa de Pós-Graduação em Engenharia de Teleinformática da Universidade Federal do Ceará como requisito parcial para a obtenção do título de Doutor em Engenharia de Teleinformática.

**Área de Concentração:** Sinais e Sistemas.

**ORIENTADOR:** PROF. DR. FRANCISCO RODRIGO PORTO CAVALCANTI

**CO-ORIENTADOR:** PROF. DR. TARCISIO FERREIRA MACIEL

UNIVERSIDADE FEDERAL DO CEARÁ  
DEPARTAMENTO DE ENGENHARIA DE TELEINFORMÁTICA  
PROGRAMA DE PÓS-GRADUAÇÃO EM ENGENHARIA DE TELEINFORMÁTICA

FORTALEZA/CEARÁ

DEZEMBRO 2015

Dados Internacionais de Catalogação na Publicação  
Universidade Federal do Ceará  
Biblioteca de Pós-Graduação em Engenharia - BPGE

- 
- S579c Silva, Carlos Filipe Moreira e.  
Contemporary electromagnetic spectrum reuse techniques: tv white spaces and D2D communications / Carlos Filipe Moreira e Silva. – 2015.  
146 f. : il. color. , enc. ; 30 cm.
- Tese (doutorado) – Universidade Federal do Ceará, Centro de Tecnologia, Departamento de Engenharia de Teleinformática, Programa de Pós-Graduação em Engenharia de Teleinformática, Fortaleza, 2015.  
Área de concentração: Sinais e Sistemas.  
Orientação: Prof. Dr. Francisco Rodrigo Porto Cavalcanti.  
Coorientação: Prof. Dr. Tarcisio Ferreira Maciel.
1. Teleinformática. 2. Espectro eletromagnético. 3. Análise SWOT. I. Título.

**CARLOS FILIPE MOREIRA E SILVA**

**CONTEMPORARY ELECTROMAGNETIC SPECTRUM REUSE TECHNIQUES:  
TV WHITE SPACES AND D2D COMMUNICATIONS**

Tese submetida à Coordenação do Curso de Pós-Graduação em Engenharia de Teleinformática, da Universidade Federal do Ceará, como requisito parcial para a obtenção do grau de Doutor em Engenharia de Teleinformática, área de concentração Sinais e Sistemas.

Aprovada em 15/12/2015.

**BANCA EXAMINADORA**

  
Prof. Dr. FRANCISCO RODRIGO PORTO CAVALCANTI (Orientador)  
Universidade Federal do Ceará – UFC

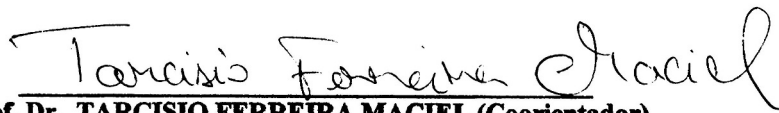
  
Prof. Dr. TARCÍSIO FERREIRA MACIEL (Coorientador)  
Universidade Federal do Ceará – UFC

  
Prof. Dr. YURI CARVALHO BARBOSA SILVA  
Universidade Federal do Ceará – UFC

  
Prof. Dr. JOSÉ F. DE REZENDE  
Universidade Federal do Rio de Janeiro – UFRJ

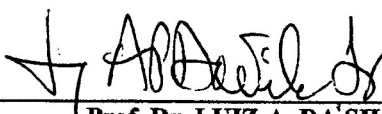
  
Prof. Dr. LUIZ A. DA SILVA  
Trinity College Dublin – TC



*To my Family, Friends, Lovers, Professors, and  
Unknowns that taught me valuable lessons that  
raised me as I am today.*

—Carlos Filipe Moreira e Silva

*“But the real way to get happiness is by giving out happiness to other people. Try and leave this world a little better than you found it and when your turn come to die, you can die happy in feeling that at any rate you have not wasted your time but have done your best.”*

—Robert Smith Baden Powell

*«Fare una tesi significa divertirsi e la tesi è come il maiale, non se ne butta via niente.»*

—Umberto Eco

---

# Acknowledgments

---

I am thankful to everyone who directly or indirectly have collaborated and helped me in the work throughout the Doctor of Philosophy (PhD) period that gives the basis for this thesis.

First of all, I must express my gratitude to Prof. Dr. Francisco Rodrigo Porto Cavalcanti who has accepted to be my supervisor even when I was still in Portugal and did not know me personally, and also for his support, guidance, trust, and advises during the supervision of my studies. Without him my travel to Brazil would not be possible. I am also grateful to my co-supervisor Prof. Dr. Tarcisio Ferreira Maciel for his knowledge, teachings, profitable discussions, and incentive during my participation in the research projects in partnership with Ericsson.

For all my co-workers and colleagues in both sides of the Atlantic Ocean from the University of Aveiro and Telecommunications Institute (Instituto de Telecomunicações, IT)-Aveiro in Portugal, and from the Federal University of Ceará and Wireless Telecommunications Research Group (Grupo de Pesquisa em Telecomunicações Sem Fio, GTEL) in Brazil, with whom I had profitable discussions and their advices, suggestions, and, especially, friendship were essential for the materialization of the thesis.

Everyone needs a spot, thus I am thankful to IT-Aveiro and more recently to GTEL research groups, not only for giving me a spot and infrastructure where I could work, but also for the welcoming during the studies, scholarship, and travelling financial support. Likewise to Post-Graduation Program in Teleinformatics Engineering (Programa de Pós-Graduação em Engenharia Teleinformática, PPGETI) for the teaching courses and for the travelling financial support that helped me to attend a conference during the PhD period.

The work that gives the basis for the thesis was assisted by the European Commission, Seventh Framework Programme (FP7), under the project 248560, ICT-COGEU, and by the Innovation Center, Ericsson Telecomunicações S.A., Brazil, under EDB/UFC.33 and EDB/UFC.40 technical cooperation contracts. I must also acknowledge the Coordenação de Aperfeiçoamento de Pessoal de Nível Superior (CAPES) for the scholarship.

Last but not least, I grateful for everything to every single member of my family that missed me (and I missed them) during this period, especially my mother, my father, my sister, my bother in law, my nice and nephew. Finally, to all my friends (they know who they are) in Portugal and Brasil that gave part of their time to spend with me, listening and advising, eating and drinking, playing or just walking around, and with whom I shared valuable moments of my life.

As someone said, “What if today, we were just grateful for everything?”

This thesis is for you all, thanks!

---

## Abstract

---

Over the last years, the wireless broadband access has achieved a tremendous success. With that, the telecommunications industry has faced very important changes in terms of technology, heterogeneity, kind of applications, and massive usage (virtual data tsunami) derived from the introduction of smartphones and tablets; or even in terms of market structure and its main players/actors. Nonetheless, it is well-known that the electromagnetic spectrum is a scarce resource, being already fully occupied (or at least reserved for certain applications). Traditional spectrum markets (where big monopolies dominate) and static spectrum management originated a paradoxical situation: the spectrum is occupied without actually being used!

In one hand, with the global transition from analog to digital Television (TV), part of the spectrum previously licensed for TV is freed and geographically interleaved, originating the consequent Television White Spaces (TVWS); on the other hand, the direct communications between devices, commonly referred as Device-to-Device (D2D) communications, are attracting crescent attention by the scientific community and industry in order to overcome the scarcity problem and satisfy the increasing demand for extra capacity. As such, this thesis is divided in two main parts: (a) Spectrum market for TVWS: where a SWOT analysis for the use of TVWS is performed giving some highlights in the directions/actions that shall be followed so that its adoption becomes effective; and a tecno-economic evaluation study is done considering as a use-case a typical European city, showing the potential money savings that operators may reach if they adopt by the use of TVWS in a flexible market manner; (b) D2D communications: where a neighbor discovery technique for D2D communications is proposed in the single-cell scenario and further extended for the multi-cell case; and an interference mitigation algorithm based on the intelligent selection of Downlink (DL) or Uplink (UL) band for D2D communications underlying cellular networks.

A summary of the principal conclusions is as follows: (a) The TVWS defenders shall focus on the promotion of a real-time secondary spectrum market, where through the correct implementation of policies for protection ratios in the spectrum broker and geo-location database, incumbents are protected against interference; (b) It became evident that an operator would recover its investment around one year earlier if it chooses to deploy the network following a flexible spectrum market approach with an additional TVWS carrier, instead of the traditional market; (c) With the proposed neighbor discovery technique the time to detect all neighbors per Mobile Station (MS) is significantly reduced, letting more time for the actual data transmission; and the power of MS consumed during the discovery process is also reduced because the main processing is done at the Base Station (BS), while the MS needs to ensure that D2D communication is possible just before the session establishment; (d) Despite being a simple concept, band selection improves the gains of cellular communications and limits the gains of D2D communications, regardless the position within the cell where D2D communications happen, providing a trade-off between system performance and interference mitigation.

**Keywords:** Electromagnetic Spectrum Management, Television, TV, TVWS, White Spaces, SWOT Analysis, Tecno-Evaluation, Device-to-Device Communications, D2D, Neighbor Discovery, Co-Channel Interference, Band Selection.

---

## Resumo

---

**N**os últimos anos, o acesso de banda larga atingiu um grande sucesso. Com isso, a indústria das telecomunicações passou por importantes transformações em termos de tecnologia, heterogeneidade, tipo de aplicações e uso massivo (*tsunami* virtual de dados) em consequência da introdução dos *smartphones* e *tablets*; ou até mesmo na estrutura de mercado e os seus principais jogadores/atores. Porém, é sabido que o espectro electromagnético é um recurso limitado, estando já ocupado (ou pelo menos reservado para alguma aplicação). O mercado tradicional de espectro (onde os grandes monopólios dominam) e o seu gerenciamento estático contribuíram para essa situação paradoxal: o espectro está ocupado mas não está sendo usado!

Por um lado, com a transição mundial da Televisão (TV) analógica para a digital, parte do espectro anteriormente licenciado para a TV é libertado e geograficamente multiplexado para evitar a interferência entre sinais de torres vizinhas, dando origem a «espaços em branco» na frequência da TV ou *Television White Spaces* (TVWS); por outro lado, as comunicações diretas entre usuários, designadas por comunicações diretas Dispositivo-a-Dispositivo (D2D), está gerando um crescente interesse da comunidade científica e indústria, com vista a ultrapassar o problema da escassez de espectro e satisfazer a crescente demanda por capacidade extra. Assim, a tese está dividida em duas partes principais: (a) Mercado de espectro eletromagnético para TVWS: onde é feita uma análise SWOT para o uso dos TVWS, dando direções/ações a serem seguidas para que o seu uso se torne efetivo; e um estudo tecno-econômico considerando como cenário uma típica cidade Europeia, onde se mostram as possíveis poupanças monetárias que os operadores conseguem obter ao optarem pelo uso dos TVWS num mercado flexível; (b) Comunicações D2D: onde uma técnica de descoberta de vizinhos para comunicações D2D é proposta, primeiro para uma única célula e mais tarde estendida para o cenário multi-celular; e um algoritmo de mitigação de interferência baseado na seleção inteligente da banda Ascendente (DL) ou Descendente (UL) a ser reusada pelas comunicações D2D que acontecem na rede celular.

Um sumário das principais conclusões é o seguinte: (a) Os defensores dos TVWS devem-se focar na promoção do mercado secundário de espectro electromagnético, onde através da correta implementação de políticas de proteção contra a interferência no *broker* de espectro e na base de dados, os usuários primário são protegidos contra a interferência; (b) Um operador consegue recuperar o seu investimento aproximadamente um ano antes se ele optar pelo desenvolvimento da rede seguindo um mercado secundário de espectro com a banda adicional de TVWS, em vez do mercado tradicional; (c) Com a técnica proposta de descoberta de vizinhos, o tempo de descoberta por usuário é significativamente reduzido; e a potência consumida nesse processo é também ela reduzida porque o maior processamento é feito na Estação Rádio Base (BS), enquanto que o usuário só precisa de se certificar que a comunicação direta é possível; (d) A seleção de banda, embora seja um conceito simples, melhora os ganhos das comunicações celulares e limita os das comunicações D2D, providenciando um compromisso entre a performance do sistema e a mitigação de interferência.

**Palavras-Chave:** Gestão de Espectro Electromagnético, Televisão, TV, TVWS, *White Spaces*, Análise SWOT, Avaliação Tecno-Econômica, Comunicações Diretas Dispositivo-a-Dispositivo, D2D, Descoberta de Vizinhos, Interferência de Co-Canal, Seleção de Banda.

---

# Figures

---

1.1.	Spectrum allocations chart for USA in 2011 .....	2
1.2.	Spectrum allocation after the digital switchover in UK .....	3
1.3.	D2D communication underlying a cellular network .....	5
1.4.	RRM procedures for D2D communications and link establishment .....	6
1.5.	Block diagram for thesis organization .....	8
2.1.	Model for the use of TVWS .....	14
2.2.	General SWOT matrix .....	16
2.3.	Practical SWOT matrix .....	16
2.4.	Money flows for the secondary spectrum market .....	18
2.5.	Kiviat diagram for the SWOT analysis: Model .....	36
2.6.	Kiviat diagram for the SWOT analysis: COM reference scenario .....	37
2.7.	Kiviat diagram for the SWOT analysis: MKT reference scenario .....	38
2.8.	Kiviat diagram for the SWOT analysis: PRIO reference scenario .....	39
3.1.	Munich area under consideration .....	44
3.2.	Munich area with the geographical classification per zone .....	51
3.3.	LTE network with additional TVWS entities for a more flexible spectrum market ..	52
3.4.	EPC area with star topology for the network under evaluation .....	57
3.5.	Total NPV and balance per year .....	59
3.6.	Contribution of each geographical area for the total NPV .....	60
3.7.	Cumulative total revenues and costs per year .....	61
3.8.	Contribution for the total CAPEX of each parameter .....	62
3.9.	Contribution for the total OPEX of each parameter .....	62
3.10.	Total NPV variation by reducing the number of clients .....	63
3.11.	Total NPV variation by increasing the price of devices .....	64
3.12.	Total NPV variation by increasing the device subsidies .....	64
3.13.	Total NPV variation by reducing the ARPU .....	65
3.14.	Total NPV variation by increasing the price of spectrum .....	65
3.15.	Proportion of spectrum costs in the total CAPEX .....	66
3.16.	Total NPV variation by increasing the cost of optical fiber .....	66
3.17.	Total NPV and balance per year .....	67
3.18.	Cumulative total revenues and costs per year for deployment scenario 1 .....	69
3.19.	Cumulative total revenues and costs per year for deployment scenario 3 .....	70
3.20.	Contribution for the total costs of each parameter .....	71
3.21.	Total NPV variation by increasing the price of spectrum (additional TVWS) .....	71
3.22.	Total NPV variation by increasing the number of paid TVWS hours .....	72
3.23.	Normalized average NPV sensitiveness .....	74
4.1.	Messages exchange between the serving BS and D2D-capable MSs .....	81
4.2.	Simulation scenario .....	84

---

4.3.	Stochastic two-state Markov channel . . . . .	85
4.4.	Total number of tries to detect all neighbors . . . . .	87
4.5.	Comparison between power vectors, semi-blind, and blind methods . . . . .	88
4.6.	Messages exchange between BSs and D2D-capable MSs . . . . .	89
4.7.	Multi-cell scenario . . . . .	90
4.8.	Iterative process for building the neighborhood matrix . . . . .	93
5.1.	Band selection technique for LTE networks . . . . .	99
5.2.	Simplified scenario illustrating the urban-microcell environment with hotspot . . .	100
5.3.	Variation of eNB threshold according the band factor . . . . .	102
5.4.	Set threshold for band selection based on received power . . . . .	102
5.5.	RRM simulation procedure . . . . .	104
5.6.	Average system spectral efficiency . . . . .	107
5.7.	SINR when hotspot is near eNB . . . . .	109
5.8.	Average cellular outage probability . . . . .	110
6.1.	The 5G multi-tier network vision . . . . .	114

---

# Tables

---

1.1.	Number of publications per type .....	10
2.1.	Reference scenarios .....	13
2.2.	Characteristics of each reference scenario .....	13
2.3.	Scale of weights for SWOT analysis .....	34
2.4.	Description of parameters for the weighting of SWOT components.....	35
2.5.	Weights of SWOT components .....	36
2.6.	Relevance of each quadrant in SWOT matrix .....	36
2.7.	The weights of variables per SWOT component .....	40
3.1.	Characterization of the area under consideration .....	45
3.2.	Number of BSs in Munich (center) for the first year .....	56
3.3.	Reference values for traditional spectrum market deployments .....	58
3.4.	Reference values for flexible spectrum market deployment .....	58
3.5.	Summary of the sensitivity analysis regarding the variation of parameters .....	73
4.1.	Simulation parameters .....	86
4.2.	Total number of tries to detect all neighbors for different percentiles .....	87
5.1.	Simulation parameters .....	105
5.2.	Average system spectral efficiency .....	106
5.3.	Average cellular outage probability .....	108



---

# Abbreviations

---

3GPP	3rd Generation Partnership Project
4G	Fourth Generation
5G	Fifth Generation
AHP	Analytic Hierarchy Process
ANACOM	Autoridade Nacional de Comunicações
ANATEL	Agência Nacional de Telecomunicações
ARPU	Average Return Per User
BS	Base Station
CAPES	Coordenação de Aperfeiçoamento de Pessoal de Nível Superior
CAPEX	Capital Expenditure
CBR	Constant Bit Rate
CCL	Common Cell List
CDF	Cumulative Distribution Function
CEPT	European Conference of Postal and Telecommunications Administrations
COGEU	Cognitive radio systems for efficient sharing of TV white spaces in EUropean context
CR	Cognitive Radio
D2D	Device-to-Device
DL	Downlink
DMRS	Demodulation Reference Signal
DTT	Digital Terrestrial TV
DVB-H	Handled Digital Video Broadcast
DVB-T	Terrestrial Digital Video Broadcast
DySPAN-SC	IEEE DySPAN Standards Committee
E-UTRAN	Evolved Universal Terrestrial Radio Access Network
EIRP	Equivalent Isotropically Radiated Power
eNB	Evolved Node B
EPA	Equal Power Allocation
EPC	Evolved Packet Core
ETSI	European Telecommunications Standards Institute
FCC	Federal Communications Commission
FDD	Frequency Division Duplex
FP7	Seventh Framework Programme
GPS	Global Positioning System
GTEL	Wireless Telecommunications Research Group
HetNet	Heterogeneous Network
HSPA	High Speed Packet Access
ICT	Information and Communication Technologies
ID	Identity
IEEE	Institute of Electrical and Electronics Engineers
IRR	Internal Rate of Return

---

ISM	Industrial, Scientific and Medical
IT	Telecommunications Institute
ITU	International Telecommunications Union
LAN	Local Area Network
LOS	Line of Sight
LTE	Long Term Evolution
M2M	Machine-to-Machine
MAC	Medium Access Control
MCS	Modulation and Coding Scheme
MIMO	Multiple Input, Multiple Output
MME	Mobility Management Entity
MR	Maximum Rate
MS	Mobile Station
MTC	Machine Type Communication
MVNO	Mobile Virtual Network Operator
NCL	Neighbor Cell List
NLOS	Non-Line of Sight
NP	Nondeterministic Polynomial Time
NPV	Net Present Value
NRA	National Regulator Authority
O&M	Operational & Maintenance
OFCOM	Office of Communications
OFDM	Orthogonal Frequency Division Multiplexing
OPEX	Operational Expenditure
P-GW	Packet Gateway
P2P	Peer to Peer
PCI	Physical-layer Cell ID
PCRF	Policy and Charging Rules Function
PDF	Probability Density Function
PF	Proportional Fair
PhD	Doctor of Philosophy
PHY	Physical
PMSE	Programme Making and Special Events
PPGETI	Post-Graduation Program in Teleinformatics Engineering
PRB	Physical Resource Block
QoE	Quality of Experience
QoS	Quality of Service
RRM	Radio Resource Management
RRS	Reconfigurable Radio Systems
RSRP	Reference Signal Received Power
RSRQ	Reference Signal Received Quality
RSSI	Received Signal Strength Indicator
S-GW	Service Gateway
SCM	Spatial Channel Model
SDR	Software Defined Radio
SINR	Signal to Interference-plus-Noise Ratio
SISO	Single Input Single Output
SLA	Service Level Agreement

---

SNR	Signal to Noise Ratio
SWOT	Strengths, Weaknesses, Opportunities, and Threats
TDD	Time Division Duplex
TETRA	Trans European Trunked Radio Access
TTI	Transmission Time Interval
TV	Television
TVWS	Television White Spaces
UE	User Equipment
UHF	Ultra High Frequency
UK	United Kingdom
UL	Uplink
USA	United States of America
USP	Unique Selling Point
WG	Working Group
Wi-Fi	Wireless Fidelity
WiMAX	Worldwide Interoperability for Microwave Access
WLAN	Wireless Local Area Network
WRC	World Radiocommunication Conference
WSD	White Space Device

---

## Symbols

---

$\alpha$	Band factor
$\mathbf{B}$	Binary matrix for BSs neighborhood relationships in a multi-cell scenario
CF	Cash flow
$P_{\text{TH}}$	Correlation or detection threshold
DCF	Discounted cash flow
$\Omega$	Neighborhood matrix
$\rho$	Normalized cross correlation metric
$\mathbf{p}$	Power vector
$R_{yz}$	Prevalent quadrant in the SWOT matrix, where $y \in A' = \{S, W\}$ and $z \in A'' = \{O, T\}$
$P$	Probability
$\mathbf{M}$	Probability transition matrix in Markov chain
$pr$	Received power
$\mathbf{P}$	Received power matrix
$Pr_{\text{TH}}$	Received power threshold
$\sigma_{\text{sh}}$	Shadowing lognormal standard deviation
$\boldsymbol{\pi}$	Steady-State vector in Markov chain
$\mathcal{B}$	Universe of CCLs
$R_x$	Weight of component $x$ in SWOT analysis, where $x \in A = \{S, W, O, T\}$

---

# Contents

---

<b>Abbreviations</b>	<b>xii</b>
<b>Symbols</b>	<b>xv</b>
<b>1. Thesis Introduction</b>	<b>1</b>
1.1. Motivation	1
1.1.1. Television White Spaces	2
1.1.2. Device-to-Device Communications	4
1.2. Objectives	6
1.3. Thesis Organization	6
1.4. Scientific Production	8
1.4.1. Main Publications	8
1.4.2. Related Publications	9
1.4.3. Publications Summary	10
<b>I. Spectrum Market for TVWS</b>	<b>11</b>
<b>2. SWOT Analysis for TVWS</b>	<b>12</b>
2.1. Introduction	12
2.2. SWOT Analysis Concept	15
2.3. Strengths	17
2.3.1. Flexible Spectrum Usage According to Regular User Needs	17
2.3.2. Incumbent Users Are Able to Resell Their Unused Spectrum	17
2.3.3. Interference Protection for Incumbent Users with Double Check	18
2.3.4. QoS with Interference Protection for Secondary Users	19
2.3.5. Prioritized Services and Interconnection	19
2.3.6. The Implementation and Management of Geo-Location Database	19
2.3.7. Competition and Innovation	19
2.3.8. Transparent Market with Real-Time Information	20
2.3.9. Flexibility in Building <i>on Demand</i> Networks	20
2.3.10. A Better Management of Costs: CAPEX Becomes OPEX	20
2.3.11. Support from Broadcasters Due to Interference Limitation	21
2.4. Weaknesses	21
2.4.1. Effective Real-Time Market: Pricing and Auction Modes	21
2.4.2. Traditional Spectrum Market Is Easier to Implement	22
2.4.3. Low Market Liquidity	22
2.4.4. Rules Against Monopolization and Market Abuse	22
2.4.5. Security: Authentication, Validation, and Blacklisting of Players	23
2.4.6. Compute the TVWS Maps	23

2.4.7.	Cross Border Issues in Interference Control and Spectrum Harmonization . . . . .	23
2.4.8.	<i>Hidden Node Problem</i> . . . . .	24
2.4.9.	Communication With the Geo-Location Database and Location Accuracy . . . . .	24
2.5.	Opportunities . . . . .	25
2.5.1.	TVWS Stability . . . . .	25
2.5.2.	Geographical Dependence of TVWS . . . . .	25
2.5.3.	Service Availability and Broadband Services in Remote Areas . . . . .	25
2.5.4.	Coverage and Enhanced Indoor Services . . . . .	26
2.5.5.	Simplifying Spectrum Trading and Positive Examples from Other Countries . . . . .	26
2.5.6.	Super Wi-Fi Concept Proposed by FCC . . . . .	26
2.5.7.	Backhaul over TVWS . . . . .	27
2.5.8.	The Needs of Bandwidth over the Next Years . . . . .	27
2.5.9.	More Efficient Use of Electromagnetic Spectrum . . . . .	28
2.5.10.	Technological Flexibility: Duplex Mode, Carrier Aggregation, and Femtocells . . . . .	28
2.5.11.	Standardization Bodies . . . . .	29
2.6.	Threats . . . . .	30
2.6.1.	Inertia in the Adoption of New Solutions . . . . .	30
2.6.2.	Low Availability of TVWS . . . . .	30
2.6.3.	Interference Negative Impact . . . . .	30
2.6.4.	Recent Auctions for 450 MHz, 800 MHz, and 900 MHz Bands . . . . .	31
2.6.5.	Delays Caused by Regulators and National Authorities . . . . .	31
2.6.6.	Dispute Resolution Mechanisms . . . . .	32
2.6.7.	Price of Spectrum and Profitability . . . . .	32
2.6.8.	Expected Price for WSDs . . . . .	33
2.6.9.	Possibility of a Second Digital Dividend . . . . .	33
2.7.	Weighting Process . . . . .	33
2.7.1.	The Formulation . . . . .	34
2.7.2.	Extraction Procedure . . . . .	35
2.8.	Conclusions . . . . .	41
<b>3.</b>	<b>Techno-Economic Evaluation for TVWS</b>	<b>42</b>
3.1.	Methodology for Network Techno-Economic Evaluation . . . . .	42
3.1.1.	Scenario Description . . . . .	43
3.2.	Network Infrastructure . . . . .	53
3.2.1.	Radio Link Budget . . . . .	54
3.2.2.	Coverage and Capacity Analysis . . . . .	54
3.2.3.	Required Number of BSs . . . . .	55
3.2.4.	Core and Transport Network Dimensioning . . . . .	56
3.3.	Deployment Costs . . . . .	57
3.4.	Results and Discussion . . . . .	59
3.4.1.	NPV, CAPEX, and OPEX for Deployment Scenarios 1 and 2 . . . . .	59
3.4.2.	Sensitivity Analysis for Deployment Scenarios 1 and 2 . . . . .	60
3.4.3.	NPV, CAPEX, and OPEX for Deployment Scenario 3 . . . . .	67
3.4.4.	Sensitivity Analysis for Deployment Scenario 3 . . . . .	68
3.5.	Conclusion . . . . .	72

<b>II.</b>	<b>D2D Communications</b>	<b>75</b>
<b>4.</b>	<b>Neighbor Discovery Using Power Vectors for D2D Communications</b>	<b>76</b>
4.1.	Introduction . . . . .	76
4.1.1.	Neighbor Discovery . . . . .	77
4.1.2.	Decentralized vs. Network-Assisted Discovery . . . . .	79
4.2.	Power Vectors and Neighborhood Matrix . . . . .	80
4.2.1.	Collecting Power Measurements from Neighbor Cell List . . . . .	80
4.2.2.	Sorting Power Measurements into Power Vectors . . . . .	81
4.2.3.	Building the Neighborhood Matrix . . . . .	82
4.2.4.	Storage and Exchange of Neighborhood Matrix . . . . .	83
4.3.	System Model and Simulation Framework . . . . .	83
4.3.1.	Cellular Scenario . . . . .	83
4.3.2.	Device-to-Device Channel . . . . .	85
4.4.	Results and Discussion . . . . .	86
4.5.	Power Vectors and Neighborhood Matrix: Multi-Cell Scenario . . . . .	88
4.5.1.	Scenario . . . . .	88
4.5.2.	Preliminary Step: Building Common Cell Lists . . . . .	90
4.5.3.	Collecting Power Measurements from Common Cell List . . . . .	91
4.5.4.	Building the Neighborhood Matrix . . . . .	92
4.5.5.	Storage and Exchange of Neighborhood Matrix . . . . .	94
4.6.	Conclusion . . . . .	95
<b>5.</b>	<b>Band Selection for D2D Communications</b>	<b>97</b>
5.1.	Introduction . . . . .	97
5.2.	Band Selection . . . . .	98
5.2.1.	Overview . . . . .	98
5.2.2.	The Underlying Concept . . . . .	98
5.2.3.	Setting the Threshold . . . . .	101
5.3.	System Model and Simulation Framework . . . . .	103
5.4.	Results and Discussion . . . . .	106
5.5.	Conclusion . . . . .	110
<b>6.</b>	<b>Thesis Conclusion</b>	<b>112</b>
6.1.	Future Perspectives . . . . .	113
	<b>References</b>	<b>116</b>

# CHAPTER 1

---

## Thesis Introduction

---

### 1.1. Motivation

Over the last years the tremendous success of smartphones and tablets along with the massive consuming of rich data applications, such as video streaming, social networking, and online gaming (just to name few) are struggling the capacity of wireless systems. Unaware of this situation, users keep demanding more and more mobile broadband data, being (conservatively) expected a growth of more than 50 % each year [1].

While the worldwide deployment of Fourth Generation (4G) cellular (especially Long Term Evolution (LTE)) and Wireless Fidelity (Wi-Fi)-private networks are making a significant effort to keep up with this demand, and even the ongoing standardization activities for LTE release 12 [2], the expectation is that they will fall short of the required capacity. Hence, the first thoughts about future Fifth Generation (5G) systems are now arising [3].

There exists a common belief that these systems will be essentially heterogeneous, following a multi-tier architecture [4], and the move to very high central carrier frequencies (30 to 300 GHz) seems to be inevitable due to the lack of available spectrum at lower frequencies, namely Ultra High Frequency (UHF)/microwave bands. As such, current research topics include, e.g., massive Multiple Input, Multiple Output (MIMO) [5], millimeter wave bands [6], Machine Type Communications (MTCs) [7], [8], Heterogeneous Networks (HetNets) [9], and spectrum sharing [10]. Nonetheless, 5G systems are only expected to be standardized around the year 2020 and it is very well-known the resistance of operators to changes.

Moreover, it is not new that the electromagnetic spectrum is a scarce resource, being already fully occupied (or at least reserved for a certain kind of applications), see figure 1.1<sup>1</sup>. Traditional spectrum markets and static spectrum management originated a paradoxical situation: the spectrum is occupied without actually being used! Long-term licenses (for 15 years or longer)—intended to prevent the various radio licensees from harmfully interfering with each other—caused that in many areas the spectrum is being underutilized.

In fact, according to some measurement campaigns [11]–[13] in the range of 30 MHz to 3 GHz, the maximum spectrum utilization is in general around 25 %, and the average use stays really below that number. Thus, traditional markets cannot guarantee the efficient and flexible spectrum allocation.

---

<sup>1</sup> [http://www.ntia.doc.gov/files/ntia/publications/spectrum\\_wall\\_chart\\_aug2011.pdf](http://www.ntia.doc.gov/files/ntia/publications/spectrum_wall_chart_aug2011.pdf)



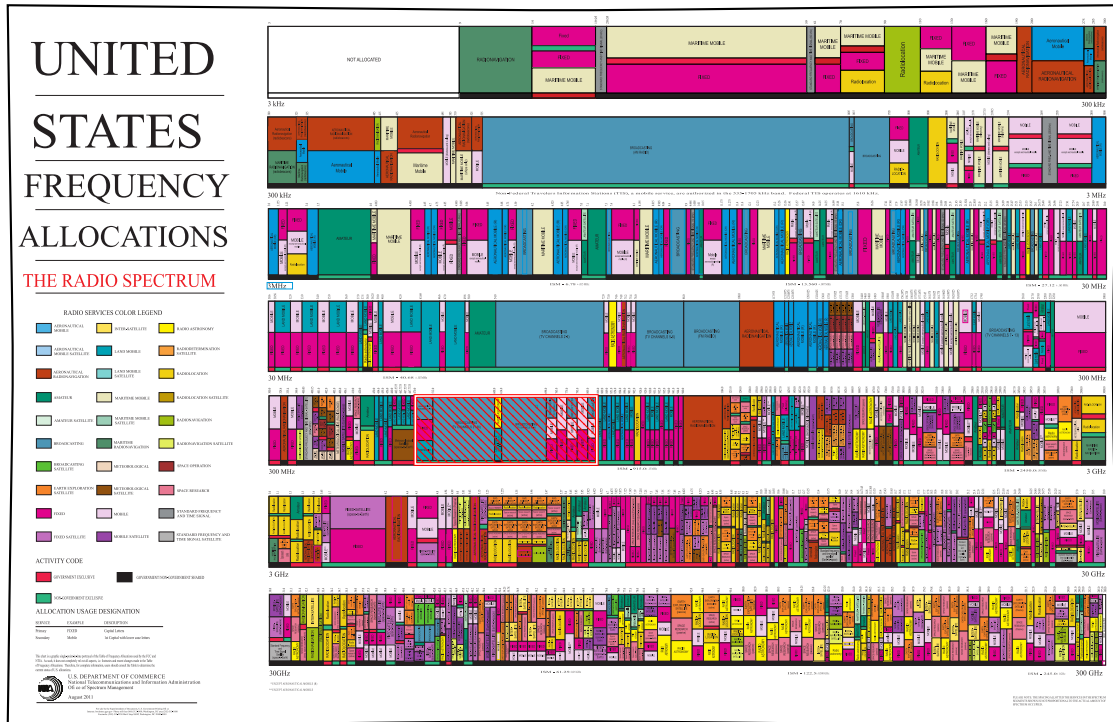

Figure 1.1: Spectrum allocations chart for USA in 2011. The red patterned square represents the TV band.

### 1.1.1. Television White Spaces

Recently, the global move from analog towards digital Television (TV) opened a wide range of new spectrum management opportunities. Since the digital TV is more spectrally efficient, the TV band (470 to 862 MHz) has been cleared (790 to 862 MHz)<sup>2</sup> for cellular use and refurbished (470 to 790 MHz) in slots of 6 or 8 MHz (USA or Europe, respectively) TV channels, which is called the digital dividend [15]. Due to the need of managing interference in TV broadcast network from neighbor towers, channels are interleaved both in frequency and space.

The vacant/unused channels are known as Television White Spaces (TVWS), or more formally, European Conference of Postal and Telecommunications Administrations (CEPT) in [16] identifies white spaces as “a part of the spectrum, which is available for a radiocommunication application (service, system) at a given time in a given geographical area on a non-interfering/non-protected basis with regard to other services with a higher priority on a national basis”.

More especially, the interleaved spectrum or TVWS arises because in a multiple frequency network any television channel is carried on a number of different frequency channels around the service area. On any given frequency channel there will be a geographical zone where the use of high-power broadcasting is not possible because of the interference it would cause, but the use of low/moderate power applications is possible, provided these are carefully designed to be compatible with the primary TV users and other secondary users (e.g., Programme Making and Special Events (PMSE) or wireless microphones) [17].

<sup>2</sup> The actual range of frequencies within the TV band depends on the country. For example, in United Kingdom (UK) that range is from 470 to 862 MHz [14], while in United States of America (USA) it is from 475 to 806 MHz [11]. In the same manner, in UK the band from 790 to 862 MHz has been cleared for cellular use, while in USA its is from 698 to 806 MHz.

For example, figure 1.2 shows the interleaved (TVWS) or retained (digital terrestrial TV) spectrum after the digital switchover in UK, where by the hand of its National Regulator Authority (NRA), Office of Communications (Ofcom), has led Europe in creating a digital dividend.

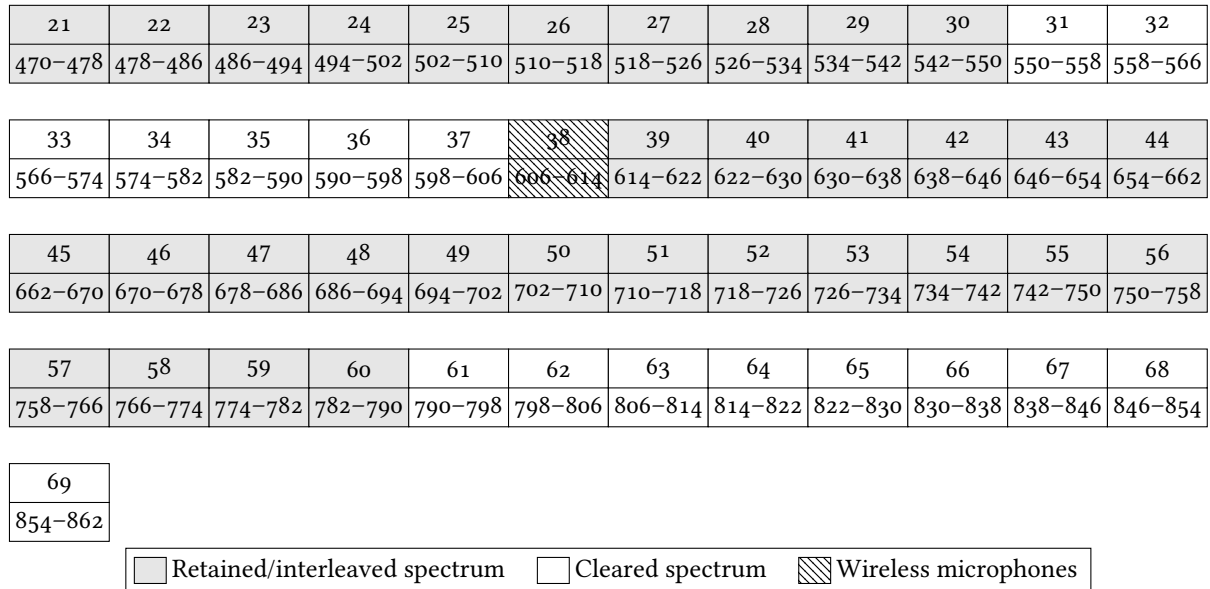

Figure 1.2: Spectrum allocation after the digital switchover in UK. The upper part of each square represents the channel number, while the bottom shows the frequency range in MHz.

In the beginning of 2015, Ofcom gave green light to TVWS [18], while in USA, Federal Communications Commission (FCC) has already authorized few TVWS database administrators [19], [20] and some of them were also granted the right to provide service to White Space Devices (WSDs) (see, .e.g., the *Public Notice*, DA 14-1309, from FCC to Google [21]).

At the time that in Europe and USA the regulation rules for the use of TVWS have already been established or are in the final stages, in Brazil and other countries in the region these initiatives have been almost non-existent. While the full transition to digital TV in Brazil is expected to be completed only after 2020, the use of TVWS would be possible right now, depending only on regulatory decisions; but the Brazilian regulator Agência Nacional de Telecomunicações (ANATEL) is more focused in licensing mobile services for LTE networks in the range of 698 to 806 MHz<sup>3</sup>.

The TV portion of spectrum is famous for its advantageous properties: signal waves travel further and penetrate in buildings easily; which are qualities already exploited by TV broadcasters. As such, the implementation of a flexible secondary spectrum market for the use of TVWS becomes a desirable fact. However, primary (licensed or incumbent) users are reluctant because they fear strong and unpredictable interference from secondary systems.

As a side note, TVWS may not always be recommended. For example, in indoor scenarios due to the extended coverage range, the congestion and self-interference rapidly limits the system capacity. In such cases, radar bands that exhibits low spectrum utilization, added by their propagation characteristics (higher propagation/penetration losses than in TVWS), are seen as ideal candidates for providing additional capacity [23].

<sup>3</sup> An interesting discussion about the digital dividend and TVWS in Brazil may be found in [22].

Despite that, in a secondary spectrum market where channels, spectrum rights, and obligations are traded in a real-time manner (and clearly stated by the NRA) along with (possible) WSDs' sensing capabilities, geo-location database [18], [19], and spectrum broker [17], [24] should limit that fear of interference. Moreover, such market is also envisioned for other bands of the spectrum [13].

### 1.1.2. Device-to-Device Communications

The scarcity of electromagnetic spectrum has also motivated the research of technologies able to increase the capacity of wireless systems without requiring additional spectrum. In this context, Device-to-Device (D2D) communication (or broadly speaking, MTC) represents a promising technology.

D2D communication<sup>4</sup> is a type of direct wireless communication between two or more network nodes, similar to direct-mode operation in professional mobile radio systems (colloquially, walkie talkies)<sup>5</sup> or the bluetooth technology, that has attracted increasing attention of scientific community in the last couple of years, mostly because of its deployment flexibility [26]. D2D communications can be implemented in Industrial, Scientific and Medical (ISM) bands for the unlicensed spectrum use, such as Wireless Local Area Networks (WLANs), or in cellular networks for a licensed use [27].

Particularly, for communications happening in a cellular network (see figure 1.3), it is evidently resource inefficient (both in terms of energy and bandwidth) to communicate via a 3rd entity (cell tower) when nature provides a direct path between closely located network nodes [28]. Therefore, the main principle that underlays each D2D communication is to exploit the proximity of devices, which provides the hop gain (direct path), reducing energy consumption, while allowing very high throughputs and low delays [27]. Moreover, the network operator does not need to be involved in the actual data transport (except for session setup signaling, charging, and policy enforcement) [29], which offloads the core network; and at cell boundaries, D2D links may be used as relays to extend the coverage area [26], [30].

Reuse gain implies that radio resources can simultaneously be used by cellular and D2D links, tightening the reuse factor (even for reuse-1 systems). The hop gain refers to the use of a single link in D2D mode rather than using Downlink (DL) and Uplink (UL) bands (in Frequency Division Duplex (FDD) systems) or different time slots (in Time Division Duplex (TDD) systems) like in cellular mode [26]. As a result, the overall system capacity and especially the spectral efficiency is increased without requiring extra power from the battery of devices.

Thereby, due to their deployment flexibility and aforementioned advantages, D2D communications are currently being considered inside 3rd Generation Partnership Project (3GPP) to facilitate MTC/proximity aware services, and security/public safety applications, becoming part of LTE standards [31]. In this context, conventional cellular and D2D communications may be respectively referred as primary and secondary communications.

However, the existence of D2D communication pose a new challenge: nodes and network must cope with new interference situations. For example, in cellular networks, the D2D links can reuse some of the already allocated physical resources [32]; and, in such case, the in-band (or co-channel) interference is no longer negligible because the orthogonality between links is

<sup>4</sup> Sometimes also referred as Peer to Peer (P2P) communication.

<sup>5</sup> See the Trans European Trunked Radio Access (TETRA) standard [25].

lost [33]. Moreover, the undesirable proximity of D2D and cellular transmitters/receiver may bring new types of inter-cell interference.

In figure 1.3 a simplified cellular network with a D2D communication is presented. The nodes 3 and 4 are in cellular mode, i.e., if node 3 tries to communicate with node 4, it first needs to send a session request to the Base Station (BS). After the permission is granted, the BS mediates the whole session setup and forwards the traffic to the respective node.

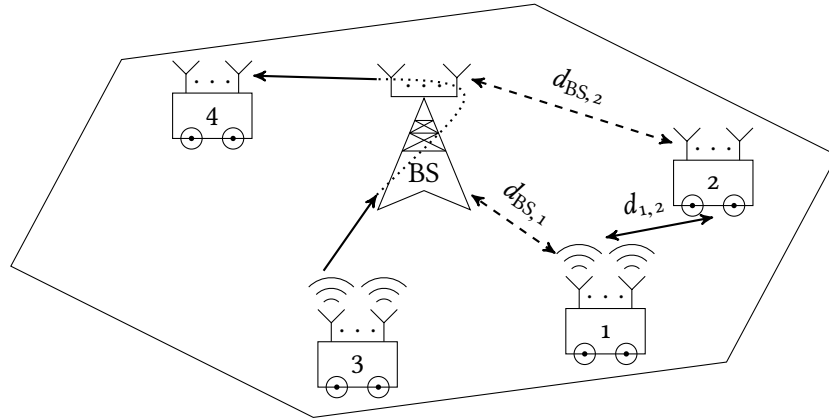

Figure 1.3: D2D communication underlying a cellular network.

Nodes 1 and 2 are in D2D mode;  $d_{BS,1}$  and  $d_{BS,2}$  denote the distance between each D2D node and BS, while  $d_{1,2}$  denotes D2D link distance, where usually  $d_{1,2} \ll \{d_{BS,1}, d_{BS,2}\}$ . When node 1 attempts to communicate with node 2 (or vice-versa), interference may happen in the UL direction towards the BS or in surrounding nodes that are in cellular mode (intra-cell interference). If the D2D communication happens at cell-edge, the interference may be caused in the BSs or nodes in the vicinity cells (inter-cell interference).

Summarizing, in order to realize the potential gains of D2D communications as a secondary network of the cellular (primary) one, some key issues must be controlled. First, at each transmission request for a D2D-capable device, it is necessary to determine its neighbors, i.e., other D2D-capable devices that are in the vicinity of the latter and may establish a D2D communication. Then, once neighbors are discovered and the target device is determined to be in the poll of neighbors, the actual link (channel) conditions must be evaluated. And, if found beneficial, Radio Resource Management (RRM) techniques are employed so that the co-channel interference caused in cellular devices is mitigated. The proposed solutions to deal with this problem include: band selection, grouping and scheduling [34], mode selection [34], [35], spatial diversity [36], power control [37]–[39], interference coordination [40], [41], or advanced coding schemes [42]. Additional references can be found in [7], [32], [43], [44].

In figure 1.4 the solutions listed above are presented in a possible simulation chain before the link establishment, which are generally designed as RRM for D2D communications. The gray blocks are the ones treated in this thesis.

The remaining sections of the chapter are organized as follows: in section 1.2 the principal and specific objectives are presented, section 1.3 depicts the thesis organization and interconnection between the main parts and chapters, and in section 1.4 the published publications during the Doctor of Philosophy (PhD) period are listed.

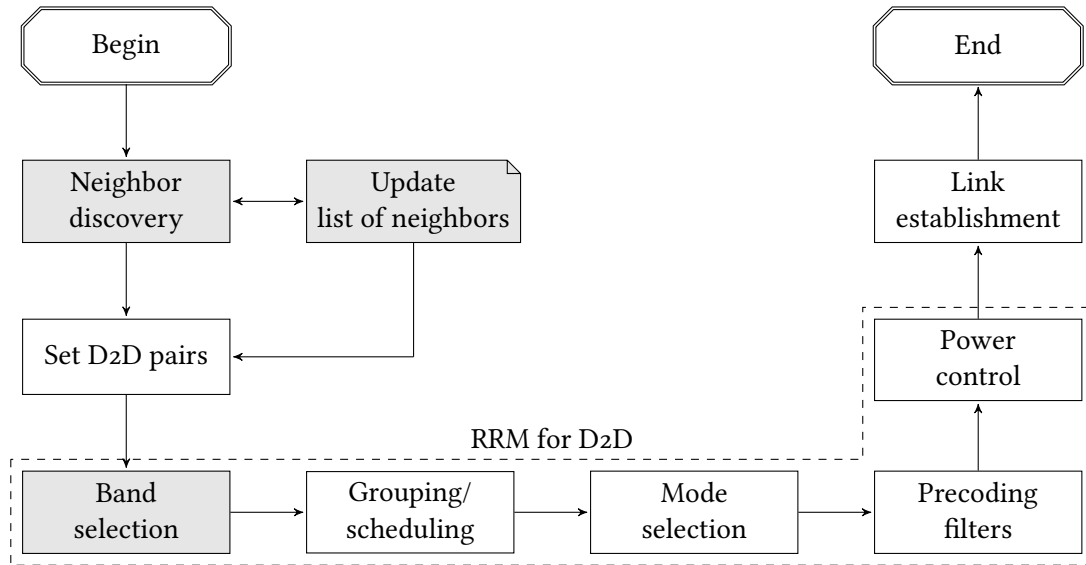

Figure 1.4: RRM procedures for D2D communications and link establishment.

## 1.2. Objectives

The principal objectives and contributions of the work presented in this thesis may be summarized as follows:

- Study techniques to overcome the spectrum scarcity in nowadays heterogeneous mobile communication systems;
- Promote solutions for the limitations that exist in state of the art solutions for mobile system, and also propose new algorithms/techniques that result in superior quality for those systems in terms of capacity, energy savings, and service quality objectives.

Particularly, the specific objectives are:

- Study the most relevant aspects for the adoption of a flexible spectrum market approach motivated by the appearance of TVWS;
- Perform a techno-economic evaluation comparing the traditional and flexible spectrum markets employing the adoption of TVWS;
- Propose an efficient neighbor discovery technique for D2D communications while being network-assisted;
- Study the co-channel interference due to the in-band spectrum sharing of cellular and D2D communications, and evaluate the effectiveness of an interference mitigation technique.

## 1.3. Thesis Organization

The rest of the thesis is organized as follows:

- Part I. Spectrum Market for TVWS:
  - Chapter 2. SWOT Analysis for TVWS: in this chapter a Strengths, Weaknesses, Opportunities, and Threats (SWOT) analysis is performed for the use of TVWS in a flexible spectrum market approach. With such analysis, it is possible to

identify the relevant aspects that may trigger the global adoption of TVWS and, as a consequence, foresee strategies to combat the resistance and promote this new market model;

- Chapter 3. Techno-Economic Evaluation for TVWS: in this chapter a detailed techno-economic evaluation for the use of TVWS is explained. As use-case examples three deployment scenarios are presented, considering the traditional and flexible market manners (2.60 GHz and 700 MHz carriers, and 2.60 GHz with additional TVWS carrier, respectively) of a LTE network around a typical European city. Results show the potential money savings that operators may reach if they adopt to use the TVWS in a flexible market approach.
- Part II. D2D Communications:
  - Chapter 4. Neighbor Discovery Using Power Vectors for D2D Communications: in this chapter it is proposed a network-assisted technique to discover D2D-capable neighbors of a first Mobile Station (MS) based on the power measurements already available in the network. Results show that with the network help, the time to detect all neighbors per MS is significantly reduced, leaving more time available for actual data transmission;
  - Chapter 5. Band Selection for D2D Communications: in this chapter a novel co-channel interference mitigation algorithm is investigated. The algorithm selects the DL or UL band to be reused by the D2D communication using a radio distance metric. Results proved that interference is mitigated in both communication directions, allowing the coexistence of cellular and D2D communication modes, which extends the common recommendation of just reusing the UL band for the D2D links.
- Chapter 6. Thesis Conclusion: this chapter gathers the most relevant conclusions of the thesis. At the end of the chapter some future works/research directions are highlighted.

Figure 1.5 shows a block diagram with the interconnection between the main parts and chapters of the thesis.

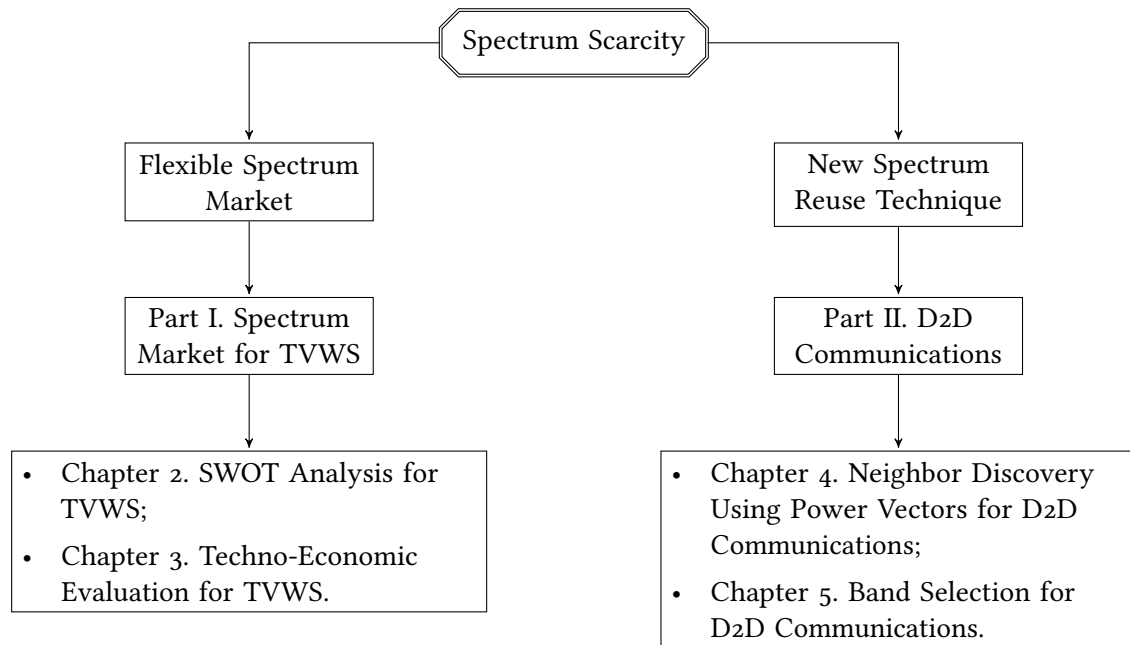

Figure 1.5: Block diagram for thesis organization.

## 1.4. Scientific Production

During the PhD period a few publications were issued as listed below. Those publications may be divided in two general categories: main and related publications. The main publications served as the basis for this thesis, while the related ones were written about correlated topics in collaboration with colleagues.

### 1.4.1. Main Publications

These are the publications that served as the basis for the thesis:

1. **C. F. Silva**, H. Alves, and Á. Gomes, “Extension of LTE operational mode over TV white spaces”, in *Future Network and Mobile Summit 2011 Conference Proceedings*, Warsaw, Poland, Jun. 2011, pp. 1–13. [Online]. Available: [http://www.ict-cogeu.eu/pdf/publications/Y2/FUNEMS\\_2011\\_COGEU\\_paper\\_n2.pdf](http://www.ict-cogeu.eu/pdf/publications/Y2/FUNEMS_2011_COGEU_paper_n2.pdf) (visited on 10/2015);
2. C. Dosch, J. Kubasik, and **C. F. M. Silva**, “TVWS policies to enable efficient spectrum sharing”, in *22nd European Regional Conference of the International Telecommunications Society (ITS 2011)*, Budapest, Hungary, Sep. 2011, pp. 1–26. [Online]. Available: <http://hdl.handle.net/10419/52145> (visited on 10/2015);
3. **C. F. M. Silva**, F. R. P. Cavalcanti, and Á. Gomes, “SWOT analysis for TV white spaces”, *Transactions on Emerging Telecommunications Technologies*, vol. 26, no. 6, pp. 957–974, Jun. 2015, Published online: Dec. 2013, ISSN: 2161-3915. DOI: [10.1002/ett.2770](https://doi.org/10.1002/ett.2770);
4. **C. F. M. Silva**, J. M. B. Silva Jr., and T. F. Maciel, “Radio resource management for device-to-device communications in long term evolution networks”, in *Resource Allocation and MIMO for 4G and Beyond*, F. R. P. Cavalcanti, Ed., New York, USA: Springer Science+Business Media, 2014, pp. 105–156, ISBN: 978-1-4614-8056-3. DOI: [10.1007/978-1-4614-8057-0\\_3](https://doi.org/10.1007/978-1-4614-8057-0_3);

5. **C. F. M. e Silva** and R. L. Batista, “Methods, nodes and user equipments for finding neighboring user equipments with which a first user equipment may be able to communicate directly”, P43774WO, Jul. 2014;
6. **C. F. M. e Silva**, T. F. Maciel, R. L. Batista, L. Elias, A. Robson, and F. R. P. Cavalcanti, “Network-assisted neighbor discovery based on power vectors for D2D communications”, in *IEEE 81st Vehicular Technology Conference (VTC 2015-Spring)*, May 2015, pp. 1–5, ISBN: 978-1-4799-8088-8;
7. **C. F. M. e Silva**, R. L. Batista, J. M. B. Silva Jr., T. F. Maciel, and F. R. P. Cavalcanti, “Interference mitigation using band selection for network-assisted D2D communications”, in *IEEE 81st Vehicular Technology Conference (VTC 2015-Spring)*, May 2015, pp. 1–5, ISBN: 978-1-4799-8088-8;
8. **C. F. M. e Silva** and G. Fodor, “Method and system of a wireless communication network for detecting neighbouring UEs, of a first UE”, P47887WO, Nov. 2015.

#### 1.4.2. Related Publications

These are the related publications that were written in collaboration with colleagues:

9. R. L. Batista, **C. F. M. e Silva**, J. M. B. da Silva Jr., T. F. Maciel, and F. R. P. Cavalcanti, “Impact of device-to-device communications on cellular communications in a multi-cell scenario”, in *XXXI Telecommunications Brazilian Symposium (SBrt2013)*, Fortaleza, Brazil, Sep. 2013. DOI: 10.14209/sbrt.2013.241;
10. R. L. Batista, **C. F. M. e Silva**, J. M. B. da Silva Jr., T. F. Maciel, and F. R. P. Cavalcanti, “What happens with a proportional fair cellular scheduling when D2D communications underlay a cellular network?”, in *IEEE WCNC 2014 - Workshop on Device-to-Device and Public Safety Communications (WCNC’14 - WDPC Workshop)*, Istanbul, Turkey, Apr. 2014, pp. 260–265;
11. R. L. Batista, **C. F. M. e Silva**, T. F. Maciel, and F. R. P. Cavalcanti, “Method and radio network node for scheduling of wireless devices in a cellular network”, P42550WO, Apr. 2014;
12. R. L. Batista, **C. F. M. e Silva**, J. M. B. da Silva Jr., T. F. Maciel, and F. R. P. Cavalcanti, “Power prediction prior to scheduling combined with equal power allocation for the OFDMA UL”, in *Proceedings of 20th European Wireless (EW’14)*, Barcelona, Spain, May 2014;
13. R. L. Batista, **C. F. M. e Silva**, T. F. Maciel, J. M. B. da Silva Jr., and F. R. P. Cavalcanti, “Joint opportunistic scheduling of cellular and D2D communications”, *IEEE Transactions on Vehicular Technology*, Submitted, ISSN: 0018-9545;
14. J. M. B. da Silva Jr., T. F. Maciel, R. L. Batista, **C. F. M. e Silva**, and F. R. P. Cavalcanti, “UE grouping and mode selection for D2D communications underlying a multicellular wireless system”, in *IEEE WCNC 2014 - Workshop on Device-to-Device and Public Safety Communications (WCNC’14 - WDPC Workshop)*, Istanbul, Turkey, Apr. 2014, pp. 230–235;
15. J. M. B. da Silva Jr., T. F. Maciel, **C. F. M. e Silva**, R. L. Batista, and Y. V. L. de Melo, “Spatial user grouping for D2D communications underlying a multi-cell wireless system”, *EURASIP Journal on Wireless Communications and Networking*, Submitted, ISSN: 1687-1499;



16. Y. V. L. de Melo, R. L. Batista, T. F. Maciel, **C. F. M. e Silva**, J. M. B. da Silva Jr., and F. R. P. Cavalcanti, “Power control with variable target SINR for D2D communications underlying cellular networks”, in *Proceedings of 20th European Wireless (EW’14)*, Barcelona, Spain, May 2014;
17. Y. V. L. de Melo, R. L. Batista, **C. F. M. e Silva**, T. F. Maciel, J. M. B. da Silva Jr., and F. R. P. Cavalcanti, “Power control schemes for energy efficiency of cellular and device-and-device communications”, in *IEEE Wireless Communications and Networking Conference (WCNC’15)*, Mar. 2015, pp. 1690–1694. DOI: [10.1109/WCNC.2015.7127722](https://doi.org/10.1109/WCNC.2015.7127722);
18. Y. V. L. de Melo, R. L. Batista, **C. F. M. e Silva**, T. F. Maciel, J. M. B. da Silva Jr., and F. R. P. Cavalcanti, “Uplink power control with variable target SINR for D2D communications underlying cellular networks”, in *IEEE 81st Vehicular Technology Conference (VTC 2015-Spring)*, May 2015, pp. 1–5. DOI: [10.1109/VTCSpring.2015.7146150](https://doi.org/10.1109/VTCSpring.2015.7146150);
19. A. R. F. de Oliveira, L. Elias, **C. F. M. e Silva**, T. F. Maciel e F. R. P. Cavalcanti, «Descoberta de vizinhos baseada em vetores de potência para comunicações D2D [Neighbor discovery based on power vectors for D2D communications]», em *XXXIII Telecommunications Brazilian Symposium (SBrT2015)*, Original document in Portuguese, set. de 2015, pp. 1–2.

### 1.4.3. Publications Summary

In table 1.1 it is shown a summary per type and the total number of publications.

Table 1.1: Number of publications per type.

Type	Number	Observation
Book chapters	1	
Patents	3	Provisional patents
Journal papers	3	Two are under revision process
Conference papers	12	
Total	19	

## PART I

---

### Spectrum Market for TVWS

---

**I**n this part the theme of Television White Spaces (TVWS) will be treated. The part is divided into the following chapters:

- Chapter 2. SWOT Analysis for TVWS: in this chapter a Strengths, Weaknesses, Opportunities, and Threats (SWOT) analysis is performed for the use of TVWS in a flexible spectrum market approach. With such analysis, it is possible to identify the relevant aspects that may trigger the global adoption of TVWS and, as a consequence, foresee strategies to combat the resistance and promote the new market model;
- Chapter 3. Techno-Economic Evaluation for TVWS: in this chapter a detailed techno-economic evaluation for the use of TVWS is explained. As use-case examples, three deployment scenarios are presented, considering the traditional and flexible market manners (2.60 GHz and 700 MHz carriers, and 2.60 GHz with additional TVWS carrier, respectively) of a Long Term Evolution (LTE) network around a typical European city. Results show the potential money savings that operators may reach if they adopt to use the TVWS in a flexible market approach.

## CHAPTER 2

---

### SWOT Analysis for TVWS

---

The digital dividend will occur when the transition from analog to digital Television (TV) becomes effective. The freed and interleaved spectrum, known as Television White Spaces (TVWS), may be a good opportunity for business related with new wireless services based on Software Defined Radio (SDR) and Cognitive Radio (CR) technologies. In this scope, the SWOT (Strengths, Weaknesses, Opportunities, and Threats) analysis—which helps in the identification of inner (internal origin) and outer (external origin) factors of a company, service, or product that characterize its position in the market—is considered a useful tool to evaluate the chances of success for this new spectrum usage paradigm. In this chapter we present a suitable SWOT analysis for the use of TVWS considering three different reference scenarios in the European context: spectrum of commons, secondary spectrum market, and prioritized services (public safety).

#### 2.1. Introduction

The electromagnetic spectrum, when correctly managed, is an important catalyst for the rapid development of economic (and social) activities through broadband wireless services provision. Since the spectrum is considered a limited resource, its scarcity implies new usage strategies and optimal allocation as collectively guided by regulatory, technical, and market domains. The current global switching from analog to digital TV has opened an opportunity to re-allocate this valuable resource [17], [60].

In one way, spectrum bands that are used for analog TV broadcasting will be cleared and reallocated to digital TV; but since the bandwidth required for digital TV is less than for the analog, part of the spectrum will be freed up. In other way, to avoid interference between neighboring broadcasting stations, the spectrum bands are geographically interleaved, which is known as TVWS. Roughly speaking, as presented in chapter 1, white spaces may be seen as “holes” in the spectrum that leave space for deploying new wireless services.

In this chapter we present a strategic positioning analysis of three scenarios (herein named reference scenarios) regarding spectrum management in the TVWS context: (a) Spectrum of commons; (b) Real-Time secondary spectrum market; (c) And prioritized services. In all cases it is assumed that some kind of cognitive radio technology is in place for spectrum sensing, which allows its opportunistic use [61]–[63].

In table 2.1 it is presented each of the spectrum management scenarios with an applicability example, while table 2.2 depicts their principal characteristics. These scenarios follow the description that can be found in [24], [64] and are aligned with the European Telecommunications Standards Institute (ETSI) Reconfigurable Radio Systems (RRS) TR 102 907 document [60].

Table 2.1: Reference scenarios.

Abbreviation	Scenario	Example
COM	Spectrum of commons	Wi-Fi over TVWS
MKT	Secondary spectrum market	LTE over TVWS
PRIO	Prioritized services	Public safety

Table 2.2: Characteristics of each reference scenario.

COM	<p>Master-Slave topology: the access point is the master while devices are slaves</p> <p>Access to geo-location database and sensing are mandatory</p> <p>At least one master acts as a gateway to access geo-location database</p> <p>Sensing can be provided by masters or slaves</p> <p>No QoS guarantees: the channel is released when incumbents (primary users) are detected</p>
MKT	<p>Market modeling, with either pricing or auction modes</p> <p>Broker acts as spectrum manager</p> <p>Exclusive usage rights, with guaranteed QoS</p> <p><i>TVWS occupancy repository</i> guarantees the protection of secondary users</p> <p>Policies are stored in the <i>policies repository</i></p> <p>Geo-Location database and safe harbor concept guarantees protection of incumbents</p> <p>Spectrum sensing is optional</p>
PRIO	<p>Adapted for policy, fire-fighters, military, etc.</p> <p>Many systems within a small bandwidth: TETRA, Tetrapol, or analog professional mobile radios</p> <p>Reconfigurable radios may use TVWS to alleviate network congestion</p> <p>Broker acts as a bridge between all public safety systems</p> <p>Services are prioritized within the broker</p>

Figure 2.1 illustrates a model for the use of TVWS with its components, agents, and relationships. To ensure the protection from interference, either from incumbent or secondary users<sup>1</sup>, only the broker assigns channels to the secondary spectrum market and to prioritized services. In the spectrum of commons, masters must access to geo-location database to ensure no interference towards incumbents (however, interference may happen towards other master-slave pairs if no additional sensing mechanism is employed).

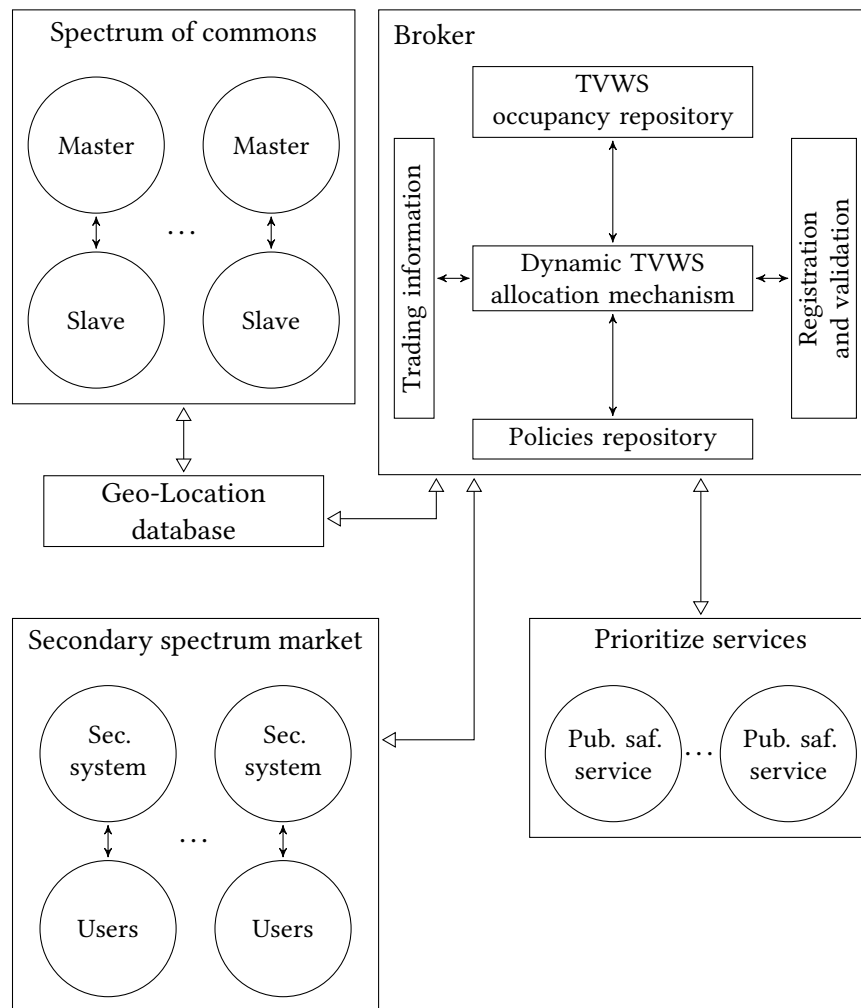

Figure 2.1: Model for the use of TVWS.

The broker has a global view about the channels that are occupied and vacant. For that it accesses the geo-location database that has information about incumbent occupation and its *TVWS occupancy repository* that has information about the already attributed channels to secondary users, i.e., the secondary occupation.

The strategic positioning analysis shown in the chapter is based on the SWOT tool which stands for Strengths, Weaknesses, Opportunities, and Threats. In the next sections we detail how this tool is applied to the TVWS context and derive a suitable SWOT matrix for the presented reference scenarios. To conclude, some possible strategies to transform weaknesses

<sup>1</sup> Incumbent users are also known as the primary spectrum users, since they own the spectrum due to regulatory decisions or traditional (primary) spectrum market, which follows a long-term licensing schema. Secondary users are the spectrum users that are only able to use it when no primary users are using it, employing opportunistic methods.

in opportunities are discussed. Notice that while the present study is focused in the European context, the proposed methodology can be extended to other regions of the world.

## 2.2. SWOT Analysis Concept

In the time of economic crisis, a systematic reflection about the chances of success for a new product<sup>2</sup> assumes great importance. It is not only important the novelty in the solutions that the new product brings, but also a close view over external factors, such as the macro economic situation, market liquidity, or even the geographical area, may be the difference between success or failure.

In this scope, the SWOT analysis is an integrated tool that allows companies to identify the main inner (within the company) and outer (environmental) factors that characterize its strategic position in a certain moment regarding the whole market situation. However, its use may not always be recommended, as it will be later discussed.

The SWOT analysis provides information that is helpful in matching the company's resources and capabilities to the competitive environment in which it operates. As such, it is an instrument in the planning process, strategy formulation, and strategy selection.

The SWOT matrix, as shown in figure 2.2, is many times used as a visual tool for the SWOT analysis. The matrix consists in two axis, each one composed by two variations: strengths and weaknesses for the inner analysis; opportunities and threats for the outer analysis. While building a matrix, the variables are some kind of overlapped, which facilitates the analysis and decision-taking regarding the planning process.

Since the idea of the analysis is to determine the position of a company regarding a new product against its competitors, the SWOT matrix presented in figure 2.3 becomes more practical. As such, the SWOT analysis shall start with the clear definition of the objective, then variables are identified and placed inside the matrix border cells at rows and columns as lists. Hence a quadrant is formed by the intersection of a row with a column. To make the analysis easier and normalized, herein we propose a scale of weights (which is not usually considered for the SWOT analysis) to be included in each variable. In the end, weights are summed in order to evaluate the relevance of each quadrant.

Depending on the prevalent variables, the product may fall into one of the four quadrants. In the first quadrant strengths-opportunities (SO), maxi-maxi, the strategies shall focus the maximization of the outcomes since the strengths are in harmony with the market opportunities; this is clearly the expansion phase. In the second quadrant weaknesses-opportunities (WO), mini-maxi, the developed strategies shall overcome the weakness variables and, at the same time, foresee the forthcoming opportunities; this is the growth phase. In the third quadrant strengths-threats (ST), maxi-mini, the strategies shall be established in the way that strengths minimize the effect of detected threats; this is a management phase. Finally, in the fourth quadrant weaknesses-threats (WT), mini-mini, the developed strategies shall try to minimize the effects of weaknesses and market threats as much as possible; this is the survival phase [65].

After a careful analysis of the European mobile communications market and the technology behind TVWS, we derive and analyze, in the following sections, a list of strengths, weaknesses, opportunities, and threats that are relevant for the three reference TVWS scenarios.

---

<sup>2</sup> The term product is considered to be generic. It can designate a physical product, a project, a model, a service, or even an idea.

	Helpful to achieve the objective	Harmful to achieve the objective
Internal origin product and company attributes	Strengths	Weaknesses
External origin environm. and market attributes	Opportunities	Threats

Figure 2.2: General SWOT matrix.

		Internal origin	
		Strengths { $S_1, S_2, \dots, S_N$ }	Weakness { $W_1, W_2, \dots, W_N$ }
External origin	Opportunities { $O_1, O_2, \dots, O_N$ }	SO Expansion	WO Growth
	Threats { $T_1, T_2, \dots, T_N$ }	ST Management	WT Survival

Figure 2.3: Practical SWOT matrix.

## 2.3. Strengths

Strengths include the positive internal factors. These are the qualities or trumps which positively distinguish the product in the market environment against the competition.

Roughly speaking, for the strengths detection, the sort of issues and questions which can be addressed when using the SWOT analysis as part of business planning and decision-making, may be enumerated as follows [66]: (a) Advantages of the new product and its capabilities? (b) Unique Selling Point (USP), i.e., what differentiates it from the concurrence? (c) What are the main innovative aspects? (d) Financial reserves and likely returns? (e) Marketing: product announcement, how to reach clients, and product distribution? (f) The price, additional values, and quality? (g) Accreditations, qualifications, and certifications? (h) Geographical location? (i) Current management and succession planning? (j) The product philosophy and its inherited values?

In the context of this work, the strengths are discussed in the following paragraphs.

### 2.3.1. Flexible Spectrum Usage According to Regular User Needs

Applicable reference scenario: COM and MKT.

In the reference scenarios both the spectrum of commons and secondary spectrum trading approaches for TVWS are considered. In the spectrum of commons usage model, there is no spectrum manager (broker) to preside over the resource allocation. This regime promotes sharing, but does not provide adequate Quality of Service (QoS) for some applications. However, for applications that require sporadic access to spectrum and for which QoS guarantees are important, temporary licensed spectrum with real-time secondary market may be the best solution. Trading allows players to directly trade spectrum usage rights with an appropriate Service Level Agreement (SLA) between the seller and buyer, thereby establishing a secondary market for spectrum leasing and spectrum auction [67].

For the secondary spectrum market, it is important to stress that it has the potential to not just open the market for new players but also to create new business opportunities for the spectrum broker entity either in the public or commercial sectors.

Of course, both regimes, spectrum of commons and secondary spectrum trading, are only possible to the extent allowed by National Regulator Authority (NRA) in each country.

### 2.3.2. Incumbent Users Are Able to Resell Their Unused Spectrum

Applicable reference scenario: MKT.

Within the concept of secondary spectrum market, the incumbent (or primary) users shall be able to resell their unused spectrum to the broker and be paid for that. This spectrum will later enter in the secondary spectrum market for reselling. Therefore, not only the optimization in the spectrum usage is achieved, but also money incoming for incumbents.

In figure 2.4 the envisaged money flows are depicted: the regulator is responsible to manage the spectrum. As such it administrates the geo-location database and/or may outsource the management of the database to a company, therefore creating new business opportunities (the same applies to the broker); on the other hand, NRA promotes the primary spectrum market (with exclusive access rights) for incumbent users: the spectrum is sold and money received;



however, since the spectrum slices are fixed and some may not even be used, primary users may resell the “spectrum excess” to the broker: spectrum is sold and incumbent users and regulators receive money for that (e.g., NRA receives a percentage of the money involved in the transaction); finally the spectrum now owned by the broker enters in the dynamism (short-term licensing schema) of the secondary spectrum market, where the spectrum is sold to secondary users.

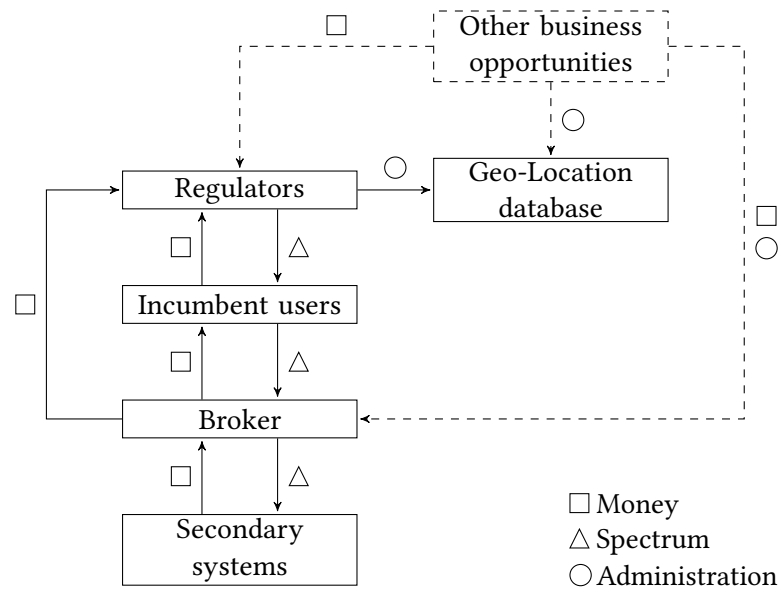

Figure 2.4: Money flows for the secondary spectrum market.

### 2.3.3. Interference Protection for Incumbent Users with Double Check

Applicable reference scenario: COM and MKT.

As it has already been identified in an earlier work [63], the necessity to provide protection for incumbents from harmful interference while enabling the opportunistic use of the spectrum, is mandatory.

In our model, for the spectrum market scenario, the protection of registered incumbent users is guaranteed through the geo-location database. Generally speaking, the database stores information about: the location, channel, and propagation maps for TV broadcasting towers; location, channel, or transmission power for the registered wireless microphones, often called Programme Making and Special Events (PMSE); and other possible protected or occupied channels, due to incumbent systems usage.

In order to protect unregistered incumbent users, such as unregistered wireless microphones, the safe harbor concept is implemented. Therefore, a couple of reserved channels per geographical region, which are not for trading, can be used by those devices. The channels may be selected during the bootstrap process [68].

In the spectrum of commons scenario there is a double check to detect incumbent users. For this scenario a master-slave architecture is envisioned where, first the master checks in the geo-location database the candidate free channels and then the slave (or even the master) senses those channels to detect if any is occupied. Thus, if any electromagnetic activity is detected, the channel is marked as occupied. However, if by the combination of geo-location database and sensing information a channel is marked as free, the slave is able to transmit.

The sensing information complements the geo-location database both in time and space, therefore a more fine-grained information is obtained. In fact, the combination of both information sources is seen as a more accurate method to protect incumbent users and avoid, e.g., the so-called *hidden node problem* [69].

#### **2.3.4. QoS with Interference Protection for Secondary Users**

Applicable reference scenario: MKT.

Inside the broker, the *TVWS occupancy repository* ensures that all secondary users are registered in the database, and the channels that were attributed to them in a previous trading process are marked as occupied. When the market opens, only the free channels are subject of trading. Moreover, a SLA is established between the player and the broker, which enforces the required QoS.

#### **2.3.5. Prioritized Services and Interconnection**

Applicable reference scenario: PRIO.

Within the broker, services are prioritized according to their type. In emergency situations, the network would be in the emergency mode. In such case, all public safety services are prioritized over any other service.

The higher priority of services in the access of TVWS is done by implementing an adequate set of policies that are stored in the *policies repository* inside the broker.

Apart from prioritizing, the broker may also act as a bridge to interconnect all the public safety systems and set a couple of restricted TVWS channels to alleviate congestion within the already existent public safety shared band.

#### **2.3.6. The Implementation and Management of Geo-Location Database**

Applicable reference scenario: COM and MKT.

Besides spectrum-sensing capabilities, in [70] the Federal Communications Commission (FCC) clearly states that White Space Devices (WSDs)—SDR and CR devices that operate in TVWS—must access a database to determine the free available channels. In this sense, all WSDs for the foreseeable future are going to use a geo-location database to avoid interference with licensed spectrum users.

In 2009, FCC issued a public notice inviting proposals for TV band device database managers. In the beginning of 2011, FCC conditionally designated nine companies as administrators for a white spaces database and outlined some important ground rules for its operation [19].

Taking the FCC as an example, we consider that multiple geo-location database administrators or multiple spectrum brokers would bring new players to the market, creating a competitive environment where policies against market abuse apply.

#### **2.3.7. Competition and Innovation**

Applicable reference scenario: COM, MKT, and PRIO.

A secondary spectrum market with temporary exclusive rights allows small players to go to the market and request (or place their bids) for spectrum. With this new concept of spectrum trading, the market is more dynamic and the granted rights are for short-term use. Therefore, small companies (e.g., hotels, associations, festivals, etc.) that require extra capacity for a specific period in time may compete with big companies for the selling spectrum.

Herein we shall also consider SDR and CR devices, e.g., with sensing capabilities and Global Positioning System (GPS) transceivers, let's say the future WSDs. However, they must be seen as more a futuristic opportunity to be developed in longer term.

### **2.3.8. Transparent Market with Real-Time Information**

Applicable reference scenario: MKT.

The introduction of spectrum trading relies on making available to the public all information related with the spectrum usage (existing spectrum ownership, individual trades, area and population coverage, technologies, services and applications, spectral efficiency, etc.). Regarding this issue, there should be a strong support by the national authorities in order to provide online registries, including the information about license conditions, rights and obligations (e.g., through a Web service).

### **2.3.9. Flexibility in Building on Demand Networks**

Applicable reference scenario: COM and MKT.

The flexibility is related with channel (or carrier) assignment. As it was already discussed, three reference scenarios are envisaged: COM, MKT, and PRIO (see table 2.1). While PRIO is related with prioritizing services and its use is mainly concerned with public safety, the other two (COM and MKT) are tailored for common use and may coexist both in time and space: if secondary user does not require QoS, it should select COM; otherwise, and if QoS is a requirement, then MKT shall be followed.

### **2.3.10. A Better Management of Costs: CAPEX Becomes OPEX**

Applicable reference scenario: MKT.

Broadly speaking, Capital Expenditure (CAPEX) is something you want to avoid, while Operational Expenditure (OPEX) is something you want to keep under control. In common business parlance, CAPEX is taken to mean upfront cash outlays for an asset depreciated over time (i.e., the initial investment), and OPEX as general run operating expenditures (i.e., maintenance costs).

Not having to pay an upfront cost may be seen as an important aspect. However, the benefits of payments over time can be erased by situational issues, e.g., money valorization, interest rates, or rental fees. Therefore, there is nothing inherently financially beneficial to switch from an upfront investment to cash outlay overtime.

Nevertheless, with any activity which is highly variable and has large capacity spikes, there can be a huge benefit to switching from an upfront investment covering the maximum of capacity over the whole time period to variable pricing based upon actual activity. Seasonal

capacity spikes in many businesses can be an order or more of magnitude from base levels of activity.

With the secondary spectrum market, players are encouraged to request TVWS on a temporary basis. The most illustrative example is the case of a Long Term Evolution (LTE) operator who wants to mitigate the lack of capacity in its network during the peak hours (or in a certain region during, e.g., summer time) and uses TVWS to overcome that situation. In such case, the acquisition of spectrum for just few hours or days would be highly beneficial.

### **2.3.11. Support from Broadcasters Due to Interference Limitation**

Applicable reference scenario: COM, MKT, and PRIO.

Broadcasters fear the interference that may be caused by mobile systems if TVWS enter in the regular spectrum market. For this cause, the ideas defended in this work, namely the implementation of interference protection ratios that limit the interference caused by secondaries in incumbent systems is seen more than welcome.

Nevertheless, their concern is that WSDs shall not block the evolution of Terrestrial Digital Video Broadcast (DVB-T) technology.

## **2.4. Weaknesses**

The weaknesses of the project include the negative internal factors. They are considered such as limiting the efficiency aspects. In order to identify the potential weaknesses of the project the following criteria may apply [66]: (a) Disadvantages of the new product? (b) Gaps in capabilities and known vulnerabilities? (c) Lack of competitive strength? (d) Past history reputation and adopted strategies to reach clients? (e) Financial issues in cash flow and start-up cash-drain? (f) Timescales, deadlines, and pressures? (g) Continuity, supply chain robustness? (h) Effects in the core activities and possible distractions?

In this work the considered weaknesses are presented in the next paragraphs.

### **2.4.1. Effective Real-Time Market: Pricing and Auction Modes**

Applicable reference scenario: MKT.

In order to implement the secondary spectrum market, a real-time market with efficient dispute resolution mechanisms is required. Therefore, definitions like the market opening time, notification of players (e.g., which kind of information shall be exchanged and how), preemptive vs. non-preemptive formulation, etc. [71] must be clearly stated.

Moreover, the broker supports both pricing mode, when the offer is greater than the demands, and auction mode, when the demands are greater than the offer [24], [64]. In the pricing mode, the seller determines a fixed price for the spectrum and the buyer simply pays the stipulated price. In the auction mode, the seller fixes a benchmark price and buyers place their bids for the auctioned band; the winning bid decides the final price. However, a successful auction requires that players have a clear understanding about the rights and obligations that are imposed on them, especially to the winner; if there is uncertainty about these issues, it will discourage competitive bidding [71]. Through the negotiation protocols, the broker maximizes its revenues as well as ensures fairness between players.

The spectrum is sold in terms of first come first served basis in the pricing approach, or the most valuable bidder wins the band depending on the auction mechanism. However, the process of determining the most valuable bidder (in real-time) is seen as a Nondeterministic Polynomial Time (NP) problem [72]. Therefore, sophisticated and computationally-intensive models shall be used, which may jeopardize the real-time market.

#### **2.4.2. Traditional Spectrum Market Is Easier to Implement**

Applicable reference scenario: MKT.

The traditional market is usually implemented by a non-real-time auction process that happens during a period of time, e.g., a couple of months [73]. It may be done in a single round of bids for the spectrum bands or with a multi-round of bids (which was the Portuguese case in recent spectrum auctions [74]).

Thus, and because real-time decisions are not required and the exclusive usage rights are for long-term periods (15 or 20 years), this market model is easier to implement.

#### **2.4.3. Low Market Liquidity**

Applicable reference scenario: MKT.

One of the main concerns for the implementation of a secondary spectrum market is the low market liquidity, for instance due to a limited number of players competing for spectrum in a given area.

In this work we consider as a use case the extension of LTE over TVWS, for the secondary spectrum market reference scenario (MKT). If we assume that most of the use of TVWS comes from LTE network operators and if we consider three or four LTE operators per country and if, as expectable its TVWS allocations are medium to long-term, the market will not be very dynamic.

On other hand, it should be pointed out that our model allows small players to enter in the spectrum market, buying spectrum for temporary use such as telemetry applications, Machine-to-Machine (M2M) applications or Wireless Fidelity (Wi-Fi)-like applications with QoS guarantee. Thus, Wi-Fi network operators would benefit from entering secondary market instead of spectrum commons (COM).

#### **2.4.4. Rules Against Monopolization and Market Abuse**

Applicable reference scenario: MKT.

The NRA shall promote the efficient utilization of the spectrum while creating conditions for new players to come into the market [75]. Therefore, and in order to avoid monopolization, a limiting process for the spectrum ownership shall be implemented [63], e.g., by *spectrum caps* [73], [74] or other means.

Maximizing the opportunities for the spectrum-using industry requires that spectrum is fully and efficiently used, and no company is able to hoard or use market power in spectrum licenses with the effect of foreclosing or limiting the competition among players [76].

Policies are described inside the broker, namely they are implemented in the *policies repository* [71]. Its omission, bad definition, or malfunction implementation may undermine the secondary market.

#### **2.4.5. Security: Authentication, Validation, and Blacklisting of Players**

Applicable reference scenario: MKT.

In the secondary spectrum market, a security mechanism is necessary to protect messages transmitted between each player and the broker, like control messages to request or assign TVWS channels, update information about the market, etc. In addition, between the broker and geo-location database a secure path may be assumed.

The importance of security can be summarized (at least) for the following situations:

- (a) Since our model assigns TVWS channels and the spectrum is a scarce resource, security attacks may lead to spectrum's occupancy from those who are not authorized;
- (b) In the secondary spectrum market, fake entities would request more TVWS channels and possibly resell them, building a parallel illegal market;
- (c) Fake entities would notify players as being the broker, and then collect money for the spectrum and spectrum rights that they do not own.

However, no esoteric security mechanisms seem to be necessary; simple and standardized mechanisms, such as the asymmetric cryptographic (or public-key cryptography) may be sufficient [64].

Moreover, the broker shall be able to shut down those WSDs that are deemed to be misbehaving. Hence, a blacklisting functionality can be built to dissociate an offending client and prevent it from re-associating with the network [77].

#### **2.4.6. Compute the TVWS Maps**

Applicable reference scenario: COM and MKT.

The process of building TVWS maps to be stored in geo-location database is not a simple task. It is based on propagation loss models that are adapted according to the geographical area and scenario under study [78].

The computation of those maps can be very intensive and to achieve a satisfying accuracy, complex and sophisticated models shall be used. In such case, the waste of white spaces is low [77].

However, more simplistic and less computationally intensive models and/or conservative values for the model parameterization may also be used, but with a higher percentage of wasted white spaces, therefore with less satisfactory results.

#### **2.4.7. Cross Border Issues in Interference Control and Spectrum Harmonization**

Applicable reference scenario: COM, MKT, and PRIO.

Spectrum harmonization, where countries across a region use the same spectrum frequency, is vital [79]. It is critical for the successful and cost-effective deployment of any wireless service

as it provides the economies of scale, which drive down the costs of devices and of the network itself, while encouraging innovation [80].

Without harmonization, the interference in these regions is predictably high [15], [79], which does seriously limit the QoS or Quality of Experience (QoE). In such case, one of following situations may happen: either the prices of devices are affordable, but due to interference level they cannot properly operate, or the costs of devices are prohibitively high (e.g., because superior narrow filters are necessary), which probably reduces their uptake. In both situations, it would harm not only consumers and the mobile industry, but also reduce the benefits that mobile technologies bring to national economies.

#### **2.4.8. Hidden Node Problem**

Applicable reference scenario: COM, MKT, and PRIO.

The hidden node happens when the incumbent signal (let's say DVB-T or PMSE signals) is not properly detected by the CR device due to buildings or trees, with partial or full blockage [69], [81]. Due to the different spatial conditions, the device erroneously detects no transmission in the current channel and no nearby receiver, thus the channel is marked as vacant. In this case, any secondary transmission on such channel would cause harmful interference to incumbent users.

In order to overcome the *hidden node problem*, the use of correct signal strength detection thresholds and/or the combination of sensing and geo-location database information must be correctly implemented.

#### **2.4.9. Communication With the Geo-Location Database and Location Accuracy**

Applicable reference scenario: COM and MKT.

For the secondary spectrum market, MKT, we foresee the use of sensing as optional, but the access to the geo-location database is mandatory; while for the spectrum of commons, COM, both geo-location information and sensing are mandatory. Therefore, a reliable communication between the broker and geo-location database is required, not only due security issues in the exchange of sensible data, but also to ensure that the broker has the latest updated version of TVWS maps.

On the other hand, a white spaces network for which the WSDs rely on a database, needs to ensure that its users know their correct location when it comes the time to request a TVWS channel. At first glance, it may be not obvious why clients need to be equipped with location information, because a *comprehensive map* [77] could be elaborated with the information of every single point within the coverage area of each Base Station (BS). However, this method can result in losses about the amount of available white space channels, as the maps result from the union of all occupied channels within the coverage area of BS. Thus, while requesting a channel, if the user's location information is provided, a more fine-grained regional information is provided and therefore the detection of available channels is more accurate and reliable.

Moreover, in such architecture any change in the spectrum occupancy by incumbent users must be disseminated to the secondary clients at their respective locations with very low latencies; or WSDs periodically query the database to learn the available white spaces [77]. In the case of *TVWS occupancy repository* inside the broker, the same procedure may also apply.

## 2.5. Opportunities

Opportunities are positive external factors that can be seen as targets to achieve or tendencies to be exploited in the future which, when used in appropriate manner, will be an impulse for the development or for weakening the threats.

Some of the questions that may be answered in order to identify the market opportunities are listed below [66]: (a) Global influences, industry, or lifestyle trends? (b) Technological development and innovation? (c) Global or niche target market developments, e.g., new vertical or horizontal markets? (d) Market response to tactics, e.g., surprise? (e) Market volume demands? (f) Competitors' vulnerabilities? (g) Partnerships, major contracts, agencies, and distribution to reach clients? (h) Geographical area, exportation, and importation? (i) Tendencies: seasonal, weather, and fashion influences?

In this work the external factors that may positively influence the product's outcomes are described in the following paragraphs.

### 2.5.1. TVWS Stability

Applicable reference scenario: COM, MKT, and PRIO.

The TVWS stability depends mainly on the power levels of TV broadcasters after the broadcast frequencies plan had been established and approved by the NRA. Both the broadcast plan and the power levels are stable, thus TVWS are also stable. In the case of unregistered wireless microphones, PMSE, the safe harbor concept (i.e., reserved and not tradable channels) may be used, therefore, not causing harmful interference.

### 2.5.2. Geographical Dependence of TVWS

Applicable reference scenario: COM, MKT, and PRIO.

The TVWS refers to the cleared and geographical interleaved electromagnetic spectrum that will be freed up after the digital TV switchover (or analog TV switch-off) is completed. The amount of cleared spectrum is known as digital dividend [68].

The TVWS geographical dependence brings many benefits, e.g., the possibility of harmonized frequencies, the balanced allocation of spectrum between different service providers, and the avoidance of interference within the boundaries of the European Union [15].

The European Union issued the document [82], which presents a couple of directives to make spectrum market more flexible and harmonized between the member states, which is clearly an opportunity to seek for new TVWS markets, being in line with the Europe 2020 initiative and the Digital Agenda for Europe.

### 2.5.3. Service Availability and Broadband Services in Remote Areas

Applicable reference scenario: COM, MKT, and PRIO.

The TVWS are localized within the Ultra High Frequency (UHF) band<sup>3</sup>, namely in the 470 to 790 MHz band [68]. This spectrum band offers excellent balance between transmission capacity

<sup>3</sup> The UHF band ranges from 300 MHz to 3 GHz.



and distance to cover. Because of its good signal propagation characteristics, less infrastructure is required to provide wider mobile coverage, meaning that (broadband) communication services can be provided in rural areas at lower cost, which would bring a beneficial social impact.

Moreover, and since rural places are not densely populated places, the availability of TVWS is higher than in urban areas allowing a bigger number of different telecommunication solutions without causing interference.

#### **2.5.4. Coverage and Enhanced Indoor Services**

Applicable reference scenario: COM, MKT, and PRIO.

Lower frequencies suffer less propagation losses, as well as, lower penetration losses through walls. Therefore, with the use of TVWS a new variety of indoor services can be provided, namely in urban areas.

Overall, this would lead to faster, cheaper, and better services with an increased possibility for content enhancement and interoperability of devices (e.g., mobile TV).

#### **2.5.5. Simplifying Spectrum Trading and Positive Examples from Other Countries**

Applicable reference scenario: MKT.

Following the initial assignment of spectrum rights and obligations to users, whether by auction or other means, circumstances may change causing initial license holders to want to trade their rights and obligations with others. Nowadays this is not possible in many countries. However, in a few countries, the secondary trading—trading of spectrum rights after the primary assignment—is possible. Examples from other countries are a critical factor in the promotion of more efficient radio spectrum use. Furthermore, it is increasingly recognized that the flexibility afforded by trading is helpful for innovation and competitiveness [71].

Regarding this topic, in United Kingdom, Office of Communications (OFCOM) has published a report [83] where the simplification of spectrum trading process is discussed and encouraged. This example may be followed by other countries, even outside the European zone.

#### **2.5.6. Super Wi-Fi Concept Proposed by FCC**

Applicable reference scenario: COM.

Super Wi-Fi is a term coined by FCC to describe a wireless networking proposal for the creation of longer-distance wireless connections [70].

Instead of using the 2.40 GHz radio frequency of regular Wi-Fi, the Super Wi-Fi proposal uses the TVWS channels to transmit Wi-Fi signals. These lower frequencies allow the signal to travel further and penetrate walls better than higher frequencies, which overcomes the short range problem of traditional Wi-Fi networks. The plan of FCC is to allow those white space frequencies to be used for free, as it happens with regular Wi-Fi.

With Super Wi-Fi, it is possible to create larger Wi-Fi networks to replace the present hotspots and companies would see their consumers offered with extensive and high-speed Wi-Fi services for cheaper prices.

Regarding this issue, objections may come from broadcasters and wireless microphone companies. However, with the implementation of protection ratios, broadcasters and microphone users shall feel safer.

### 2.5.7. Backhaul over TVWS

Applicable reference scenario: MKT and PRIO.

In LTE release 8, the predicted downlink theoretical throughput peak rates may reach up to 300 Mbit/s per BS with  $4 \times 4$  Multiple Input, Multiple Output (MIMO) [84], which requires new backhaul<sup>4</sup> strategies in order to deliver cost effective networks.

The choice of optical fiber seems natural since it can deliver almost unlimited bandwidths. While it is true for mobile operators that have already installed their own fiber connection between the access network and core network (which may be reused from their previous networks), it may not be the case for an operator that does not own a fiber connection and must lease it from a third-party, or build out a new fiber plant.

For the latter case, a microwave link may be seen as an alternative. A microwave link (including the installation and lifetime operation) can be three to five times cheaper than an Ethernet link and almost 10 times cheaper than the fiber link for urban and sub-urban areas [85].

Microwave technology has evolved and solutions using multi-carrier and MIMO techniques may notably increase the downlink throughput peak rate up to 1.60 Gbit/s per link [85], which is comparable with the one achievable using optical fiber. The previous downlink throughput peak rate is likely to be achieved with a bandwidth of 50 MHz, which can be obtained employing carrier aggregation (see section 2.5.10). Moreover, advances in modulation technology and signal processing promise to increase capacity in the near future.

Due to excellent propagation characteristics of lower frequencies and in times where the available spectrum is scarce, the use of TVWS for backhaul links, especially in MKT scenario, may be seen as an alternative.

### 2.5.8. The Needs of Bandwidth over the Next Years

Applicable reference scenario: COM and MKT.

In 2011 the global mobile data traffic increased 133 % [86], with respect to previous year and this increase is predicted to continue over next several years [1], [86]. The key drivers in this rapid growth are related with the maturity of already deployed networks, such as Wi-Fi and High Speed Packet Access (HSPA), and the roll-out of new mobile technologies, namely, LTE. Moreover, the popularity of Wi-Fi-enabled devices, such as smartphones and tablets, boomed the network traffic. For the next decades, a huge increase in the M2M wireless communications is also expected [1], [87].

The need of electromagnetic spectrum to fulfill the above demands for wireless broadband services is evident. For this purpose, the use of TVWS along with WSDs is already a subject under study by some NRA, such as FCC [70] and OFCOM [88].

Additionally, in World Radiocommunication Conference (WRC)-07 it had already been identified, according to International Telecommunications Union (ITU)'s system of regional

<sup>4</sup> In a hierarchical telecommunications network the backhaul portion of the network comprises the intermediate links between the core (or backbone) network and the access network.

classification, the following blocks of digital dividend: 72 MHz for Europe/Africa (Region 1) and Asia/Oceania (Region 3), and 108 MHz for Americas (Region 2) and some countries in Asia/Oceania (Region 3). However, the mobile industry considers these identifications to be the minimum amount required in each region, and states that a larger bandwidth should be cleared—at least 100 MHz per each region—, which represents approximately 25 % of the spectrum allocated for terrestrial broadcasting after the digital TV switchover [80].

Moreover, operators also claim that more spectrum (i.e., more licensed channels) would bring more players into the telecommunications market, diversifying the offer of new products and, at the same time, lowering their prices.

### **2.5.9. More Efficient Use of Electromagnetic Spectrum**

Applicable reference scenario: MKT.

A market-based approach for spectrum management might be considered as a way to improve the efficient use of the radio spectrum [67]. This mechanism would imply that underutilized spectrum assets could be transferred to individuals or organizations, deriving in greater economic returns from their use. In this way, it would lead to an enhanced use of the radio spectrum [24], [64].

Moreover, new enhancements in technology allow the coexistence of different radio technologies in a relative small portion of the spectrum. This can be more related with LTE because of its flexibility to operate in different contiguous bandwidths. The 1.40 MHz, 3 MHz, and 5 MHz bandwidths that were specified in the LTE release 8 can be accommodated within the 8 MHz bandwidth of a DVB-T channel. However, if higher bandwidths (10 MHz, 15 MHz, or 20 MHz, also specified in the same LTE release) are required, different contiguous or non-contiguous DVB-T channels can be aggregated to provide the total bandwidth. This feature is not currently supported by LTE, but it will be fully supported in LTE-Advanced, with the requirement of backward compatibility [89].

Moreover, it seems inevitable that the range of band combinations that have to be supported will continue to increase, to provide a dynamic load balance between carriers according to traffic demand [90]. However, some precautions must be taken because an incorrect allocation of the spectrum would imply spectrum fragmentation and, therefore, spectrum wastage.

### **2.5.10. Technological Flexibility: Duplex Mode, Carrier Aggregation, and Femtocells**

Applicable reference scenario: COM, MKT, and PRIO.

Additional to adaptive modulation scheme, robust access techniques, and the ability to use different bandwidths, new standards can use different duplex modes, be deployed in femtocells, and also use carrier aggregation. All these new improvements in standards make them more flexible to operate in a more constrained environment and be adaptable to a certain number of different situations.

For example, since LTE can be deployed both in Frequency Division Duplex (FDD) and Time Division Duplex (TDD), it seems more reasonable to deploy it in TDD to be used in TVWS, because a pair of carriers and a bandwidth gap would not be required as in FDD, therefore less spectrum would be occupied.

Also, as previously discussed, if higher bandwidths are required, contiguous or non-contiguous TVWS channels can be aggregated to provide total aggregated bandwidth, thus satisfying the demands of clients.

Finally, femtocells deployed using TVWS carriers may be used to cover indoor corridors (e.g., in shopping malls or stadiums) and for short-range communications, or even improve coverage at cell-edge, without interfering with macrocells.

### 2.5.11. Standardization Bodies

Applicable reference scenario: COM, MKT, and PRIO.

We will not go deep into the standardization activities, however it is noticeable that TVWS is growing in interest, and the proof is the ongoing work in several standardization bodies that in some way consider the use of TVWS and cognitive spectrum access: from the Physical (PHY) layer definition to networking aspects. These groups can be listed as follows:

- (a) ETSI RRS<sup>5</sup> has four Working Groups (WGs) that deal with various aspects of TVWS, namely, WG 1: System Aspects, WG 2: Radio Equipment Architecture, WG 3: Functional Architecture and Cognitive Pilot Channel, and WG 4: Public Safety;
- (b) IEEE 802.11af<sup>6</sup>, formally known as Wireless LAN in the TV White Space, defines modifications to both the 802.11 PHY layer and the 802.11 Medium Access Control (MAC) layer to meet the legal requirements for channel access and coexistence in TVWS;
- (c) IEEE P1900.X<sup>7</sup>, formally known as IEEE DySPAN Standards Committee (DySPAN-SC), is seeking proposals for standards projects in the areas of dynamic spectrum access, cognitive radio, interference management, coordination of wireless systems, advanced spectrum management, and policy languages for next generation radio systems;
- (d) IEEE 802.19<sup>8</sup>, formally known as Wireless Coexistence WG, develops standards for coexistence between wireless standards of unlicensed devices and reviews coexistence assurance documents produced by WGs developing new wireless standards for unlicensed devices;
- (e) IEEE 802.22<sup>9</sup>, formally known as WG on Wireless Regional Area Networks, is devoted to develop a standard for a cognitive radio-based PHY/MAC air interface for use by license-exempt devices on a non-interfering basis in spectrum that is allocated to the TV broadcast service.

Moreover, ITU published the resolution ITU-R 58 [91] that resolves to continue studies for the implementation and use of cognitive radio systems in wireless services and give a particular attention to enhance the coexistence and sharing among them.

<sup>5</sup> <http://www.etsi.org/website/technologies/RRS.aspx>

<sup>6</sup> [http://www.ieee802.org/11/Reports/tgaf\\_update.htm](http://www.ieee802.org/11/Reports/tgaf_update.htm)

<sup>7</sup> <http://grouper.ieee.org/groups/dyspan/>

<sup>8</sup> <http://ieee802.org/19/>

<sup>9</sup> <http://ieee802.org/22/>

## 2.6. Threats

Threats include the negative external factors that are seen as barriers for the development of the product.

These factors are out of the control of the company and if not properly considered and evaluated may conduct the product to be a failure. Some of the relevant questions that shall be considered to detect threats are summarized next [66]: (a) Political, legislative, and environmental effects? (b) Technological development, ideas, services, and innovation? (c) Competitors' intentions? (d) Vital contracts and partnerships? (e) Insurmountable weaknesses? (f) Financial and credit pressures? (g) The economic situation and market demands? (h) Seasonality and weather effects?

The relevant threats that may occur in connection with this work are depicted in the following paragraphs.

### 2.6.1. Inertia in the Adoption of New Solutions

Applicable reference scenario: COM, MKT, and PRIO.

At first glance, clients tend to refuse the adoption of new solutions even when they prove to be better than the previous ones. The resistance to change is a natural behavior and comes from the fact that it is safer to rely on well-known solutions than to face the risk of unknown ones.

Regarding the TVWS, the fear of interference that WSDs may impact in incumbent users is real, even when they are protected through the combination of geo-location database and sensing information. Likewise, the main concern of broadcasters is that the WSDs would interfere or even block the evolution of DVB-T technology in the European context.

However, in the model proposed herein, broadcasters are not seen as competitors, but partners in the promotion of a more flexible and agile spectrum use.

### 2.6.2. Low Availability of TVWS

Applicable reference scenario: COM, MKT, and PRIO.

According to [75] the quantity of spectrum available for mobile communications is limited in practice (at least) by, apart from monopolization issues, three further factors:

- (a) Spectrum may be explicitly preempted by the regulation from use for other purposes;
- (b) Possible restrictions on the technology or generation of technologies to which a particular frequency can be used;
- (c) Some non-preempted frequencies, while being technically feasible, are just uneconomic, e.g., when potential mobile operators are simply outbid by other players.

The availability of TVWS is a basic premise of the present work and its scarcity is a major threat that should be considered carefully.

### 2.6.3. Interference Negative Impact

Applicable reference scenario: COM, MKT, and PRIO.

Harmful interference is always a limiting factor in the adoption of new radio solutions. Therefore, if the minimum acceptable QoS cannot be guaranteed, the QoE will be deteriorated and clients will search for other better solutions.

On the other hand, the ones that own traded spectrum have the right to send and receive radio frequency signals without harmful interference.

Under the European rules, the member states have the right to set the conditions for the spectrum's usage that any radio equipment must meet. The set of rules can include, e.g., appropriate power limits that aim to mitigate the interference caused on other equipment. Additionally, those conditions can be European-wide coordinated or, alternatively, only be considered within each member state.

#### **2.6.4. Recent Auctions for 450 MHz, 800 MHz, and 900 MHz Bands**

Applicable reference scenario: COM, MKT, and PRIO.

With recent auctions for 450 MHz, 800 MHz, and 900 MHz bands, operators may feel that it is not worth going to the real-time secondary spectrum market for TVWS because their needs for frequencies with better propagation conditions may already be satisfied; and in the real-time secondary market there is no guarantee to have a winning bid.

Moreover, in traditional spectrum markets they have exclusive rights for at least 15 years, which avoids the uncertainty of winning in the case of a secondary market and having exclusive rights only for short period of time.

#### **2.6.5. Delays Caused by Regulators and National Authorities**

Applicable reference scenario: COM, MKT, and PRIO.

In the regulation aspect, it is clear that NRA in most European countries (with the exception of United Kingdom [92]) are still in an exploration stage regarding the legislation for the use of TVWS. They need to understand the relevant (business) requirements, industrial costs, potential size of the market and investment profitability, in order to be able to advice on effective regulation. At this stage, there is a common European interest in establishing some form of partnership between European standardization bodies, companies, and regulation, on the basis of initial business plans [93].

Therefore, in the European perspective, for cognitive access in UHF, we can see there are numerous challenges facing both regulators and industry. Regulators will need to ensure that they have specified appropriate conditions of access which protect incumbent users and allow feasible operation of CR devices and systems, including additional regulatory considerations such as the management of different database solutions [94].

For example, in the Portuguese case, the ones that own unused spectrum may resell it. However, the seller must prior communicate to the NRA, Autoridade Nacional de Comunicações (ANACOM), its intention of selling and ensure that any restriction will be respected and the buyer will not cause harmful interference to neighbor systems. In order to become effective, ANACOM will pronounce itself within 45 days and may be against the sale or impose certain conditions<sup>10</sup>. This delay is not conformable with the envisaged real-time market.

<sup>10</sup> Information obtained in a private e-mail from ANACOM in answer to the authors request.

### 2.6.6. Dispute Resolution Mechanisms

Applicable reference scenario: MKT.

The dispute resolution among market players has to take into account that the normal operation of each system can adversely affect the performance or even prevent the operation of others, due to harmful interference if both systems use the same band (e.g., in the opportunistic spectrum use) or if no safeguard bands are properly considered to separate them.

The continuous reselling of spectrum becomes possible when a secondary market operates in respect of either spectrum that has been auctioned or spectrum initially allocated by administrative methods but which is now cleared for trading. Also, when a secondary market is combined with flexibility in spectrum use, licenses can be deployed in a new innovative use [71].

Policy-makers and regulators are recognizing that the effective dispute resolution is very important of nowadays telecommunications. The failure in resolving disputes quickly and effectively can [95]:

- (a) Delay the introduction of new services and infrastructure;
- (b) Block or reduce the flow of capital from investors;
- (c) Limit competition, leading to higher pricing and lower service quality;
- (d) Retard liberalization—and with it, general economic, social, and technical development.

It is, therefore, necessary to establish clear and efficient procedures for disputes resolution and other concerns. The actual dispute resolution mechanisms are operated by humans in courts or other justice institutions, which may not be suitable for a real-time secondary spectrum market.

In this sense, reactive resolution mechanisms, such as force, adjudication, and arbitration may condemn the real-time market to be a flop; while proactive approaches, like negotiation, mediation, and reconciliation, are seen as favorable [96].

### 2.6.7. Price of Spectrum and Profitability

Applicable reference scenario: MKT.

It is well-known that lower frequencies, namely in the UHF band, is more expensive [75] due to their excellent propagation conditions and penetration through walls<sup>11</sup>.

However, either in lower or higher frequency bands, the holders of transmission rights are forced to accept agreements that allow Mobile Virtual Network Operator (MVNO) to use their networks to provide telecommunication services to end-users, equivalent to the ones provided to their own clients [74], [97].

This is not only related with spectrum monopolization issues, but also with its profitability. As such, it may be more profitable for a MVNO to rent the infrastructure of incumbents than to participate in the secondary spectrum market. The same conclusion may be reached by the incumbent for its own profitability.

<sup>11</sup> See the case of recent Portuguese auctions, where the price for  $2 \times 5$  MHz of bandwidth in 2.60 GHz had a price of €3 million, while for 800 MHz the price was €45 million [74], i.e., 15 times more expensive.

### **2.6.8. Expected Price for WSDs**

Applicable reference scenario: COM, MKT, and PRIO.

The price of devices is related with not only the technology they carry inside them (e.g., video camera, GPS transceiver, voice recording, or radio frequency signal processing), but also with the factory form (i.e., dimension and weight).

In the case of white spaces, and since WSDs operate in a frequency band of 470 to 790 MHz with DVB-T channels of 8 MHz bandwidth each (in Europe), the biggest problem is related with the required components for the radio frequency front end to process the signals that may be receive in each channel (at the same time). Besides, better analog-digital converters and higher processing capabilities are required, which would lead devices' batteries to be drawn quickly. The required processing capabilities become even more exigent if sensing features are also added.

Moreover, the previously enumerated enhancements must be included in a small and light package in order to be a salable product, which may increase even more the final price.

### **2.6.9. Possibility of a Second Digital Dividend**

Applicable reference scenario: COM, MKT, and PRIO.

A second digital dividend is motivated by the demands of the mobile broadband industry seeking to gain further access to valuable sub-1 GHz frequencies. It is also motivated by the need to globally align the frequency bands released from the first digital dividend. The WRC-07 decisions placed new mobile allocations from the first dividend in different parts of the UHF band (790 to 862 MHz in Europe/Africa and Asia/Oceania, and 698 to 806 MHz in Americas and some countries in Asia/Oceania [80]). Consequently, clearance of the 700 MHz band is one of the most likely manifestations of any second digital dividend.

However, while such a clearance would reduce the total Digital Terrestrial TV (DTT) allocations, TVWS is unlikely to be completely removed, unless DTT networks move to single-frequency network basis. Such transition would require new international agreements and frequency planning, i.e., a successor to Geneva 2006 (GE06) Agreement. Also, if DTT networks move to a more dense deployment model to accommodate mobile TV on a single common DTT and Handled Digital Video Broadcast (DVB-H) network, then the amount of TVWS would be substantially reduced. However, any of these changes to DTT networks would come at considerable cost to the broadcaster network operators and are likely to be strongly resisted.

In terms of the timing of such change, there are no proposals for a new dividend at WRC-12. The earliest prospect for international consideration of changes is likely to happen at WRC in 2015 or 2016.

## **2.7. Weighting Process**

In this section all the previously discussed variables are weighted according to their relevance for the product and/or the market. It is a common sense that not all variables have the same relevance. Therefore, a scale of weights for variables and the procedure to extract the final weight of each SWOT component are proposed. At the end, by the combination of weights,



the most relevant quadrant is revealed: strengths-opportunities (SO), weaknesses-opportunities (WO), strengths-threats (ST), or weaknesses-threats (WT).

### 2.7.1. The Formulation

As we propose in this chapter, an important step after defining all the variables that take place in the SWOT matrix (recall figure 2.3) is to weight each variable.

Variables have different weights when it comes the time to determine the quadrant where the product belongs in the SWOT matrix, and design strategies to face obstacles and challenges in the market approach. Therefore, weights are given according to the importance of each variable for the product and/or the market. In table 2.3 the scale of weights is presented.

Table 2.3: Scale of weights for SWOT analysis.

<i>R</i>	Description
3	Extremely important
2	Very important
1	Important

The way that variables are weighted depends on the particularities of each product. However, some general rules apply. For a weight of value 3, the variable must be extremely important and with it the product will surely succeed and without it the product will be a failure. For a weight of value 2, the variable shall be very important and can be related with the importance of some particular aspects, mostly (but not strictly) within the product. For example, the key points of the product or what clearly differentiates it from competitors, will have a weight of value 2. A weight of value 1 is given to all other variables, that positively or negatively contribute for the product.

Other way to think about weights is to differentiate them in two categories: strengths/opportunities vs. weaknesses/threats. For the first category, the presence of variable is required for the product's success. While, for the second category, the absence of variable is required for product's success. Therefore, the main question becomes the determination of variable-related requirements. Strong required variables, i.e., essential variables, would have a weight of value 3. Medium required (or less essential) variables would have a weight of value 2. All other variables would have a weight of value 1.

In the case of our model, the variables with weight of value 3 are the ones related with TVWS availability. A weight of value 2 is attributed to variables that are related with reference scenarios: the broker to preside over spectrum allocations, secondary real-time spectrum trading, and protection from interference. Disruptive product's novelties to resolve concrete problems may have a weight of value 3. The weight of value 1 is attributed to all other variables that, while being relevant, are not very important, e.g., legislation issues, common aspects with other products, or strong dependence on the used technology. After a careful analysis of all variables, weights were attributed as shown in table 2.7.

The variables considered for the SWOT analysis are relevant in a certain concrete time. Therefore, we think it might be useful to index each variable to a time-dependent function (e.g., time variation in the price of goods). However, for the current analysis it was considered that variables are only present when the analysis is done.

Table 2.4: Description of parameters for the weighting of SWOT components.

Parameter	Description
$A = \{S, W, O, T\}$	Set of components: Strength, Weakness, Opportunity, and Threat
$x, x \in A$	The component
$R_x$	Weight of component $x$
$N_x$	Total number of variables for component $x$
$N, N = \sum_{i \in A} N_i$	Total number of variables
$n, n \in \{1, 2, \dots, N_x\}$	Index of variable for component $x$
$R, R = \{1, 2, 3\}$	Set of weights (see table 2.3)
$r_n, r_n \in R$	Weight of variable $n$ for component $x$

In equation (2.1) we present our formula to calculate the weight of each component in SWOT analysis and in table 2.4 the description of each used parameter.

$$R_x = \left[ \frac{\text{Part 1}}{[r_1 + \dots + r_N]_x} \times \frac{\text{Part 2}}{N_S + N_W + N_O + N_T} \right]^{\frac{1}{2}}, \quad (2.1)$$

where part 1 refers to the average weight of variables for component  $x$ , and part 2 refers to the weight of the same component within all SWOT components. The condensed version of the formula is

$$R_x = \left[ \frac{\left( \left[ \sum_{n=1}^N r_n \right]_x \right)^2}{N_x \sum_{i \in A} N_i} \right]^{\frac{1}{2}}. \quad (2.2)$$

Moreover, we are also interested in determining the prevalent quadrant in the SWOT matrix using equation (2.3).

$$R_{yz} = R_y + R_z, \quad (2.3)$$

where  $y \in A' = \{S, W\}$  and  $z \in A'' = \{O, T\}$ .

### 2.7.2. Extraction Procedure

The weighting extraction procedure, as previously defined, is next systematized:

- First, we start to weight each variable, according to the rules defined in section 2.7.1 for our model, as summarized in table 2.7. For each reference scenario, only scenario-existent variables are weighted;
- Then we calculate the weight per component using equation (2.2), as presented in table 2.5;
- Finally, we extract the relevance of each quadrant using equation (2.3) in order to find the prevalent one, as shown in table 2.6.

As it can be seen, the relevance of all quadrants is similar (figures 2.5 to 2.8 present the same values as in tables 2.5 and 2.6, but they are visually more indicative about the trends in results). Nevertheless, and according to the given weights, the most relevant is the strengths-threats (ST) quadrant, i.e., the management phase for the model and different scenarios. Therefore maxi-mini strategies shall be followed in the promotion of TVWS, or in other words, strategies must focus on the most relevant strengths about the flexible use of TVWS and spectrum management in order to weaken the predictable threats.

Table 2.5: Weights of SWOT components.

Component ( $x$ )	Weight ( $R_x$ )			
	Model	COM	MKT	PRIO
S	0.81	0.90	0.77	0.66
W	0.74	0.70	0.76	0.65
O	0.76	0.92	0.72	0.87
T	0.89	1.06	0.92	1.21

Table 2.6: Relevance of each quadrant in SWOT matrix.

Quadrant ( $yz$ )	Relevance ( $R_{yz}$ )			
	Model	COM	MKT	PRIO
SO	1.57	1.82	1.49	1.53
WO	1.50	1.62	1.48	1.52
ST	1.70	1.96	1.69	1.87
WT	1.63	1.76	1.68	1.86

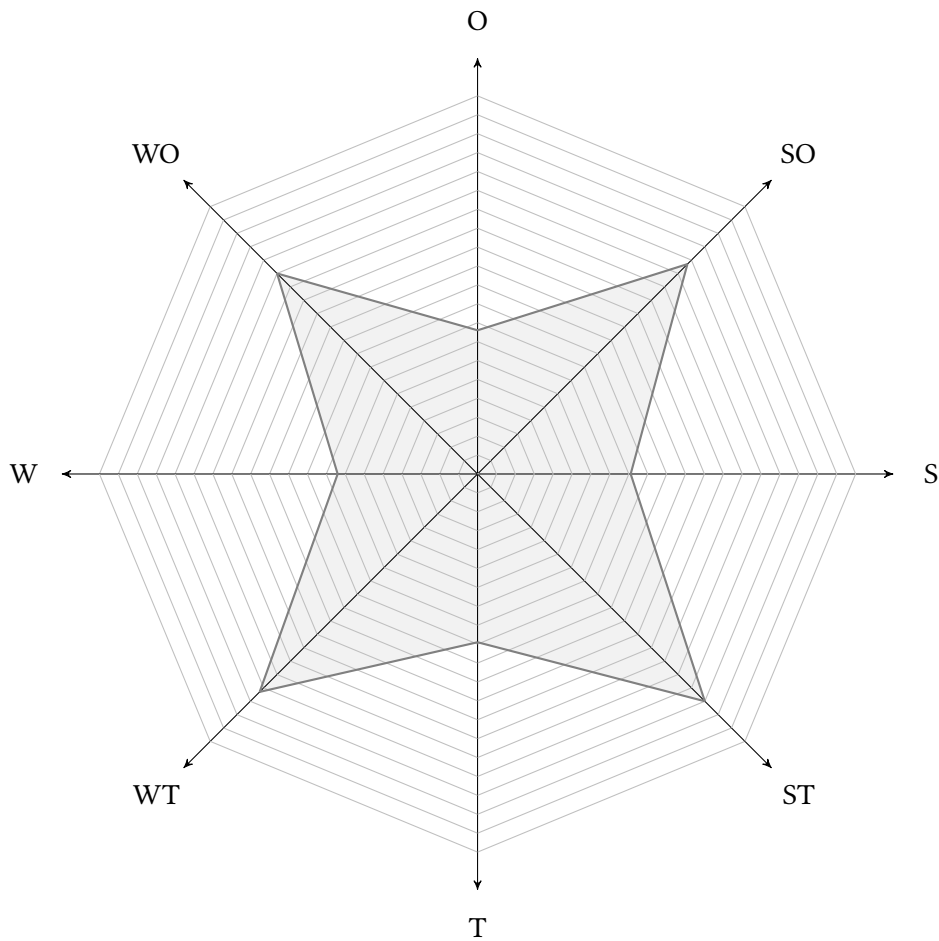

Figure 2.5: Kiviat diagram including weights of components and relevance of matrix quadrants for the SWOT analysis: Model.

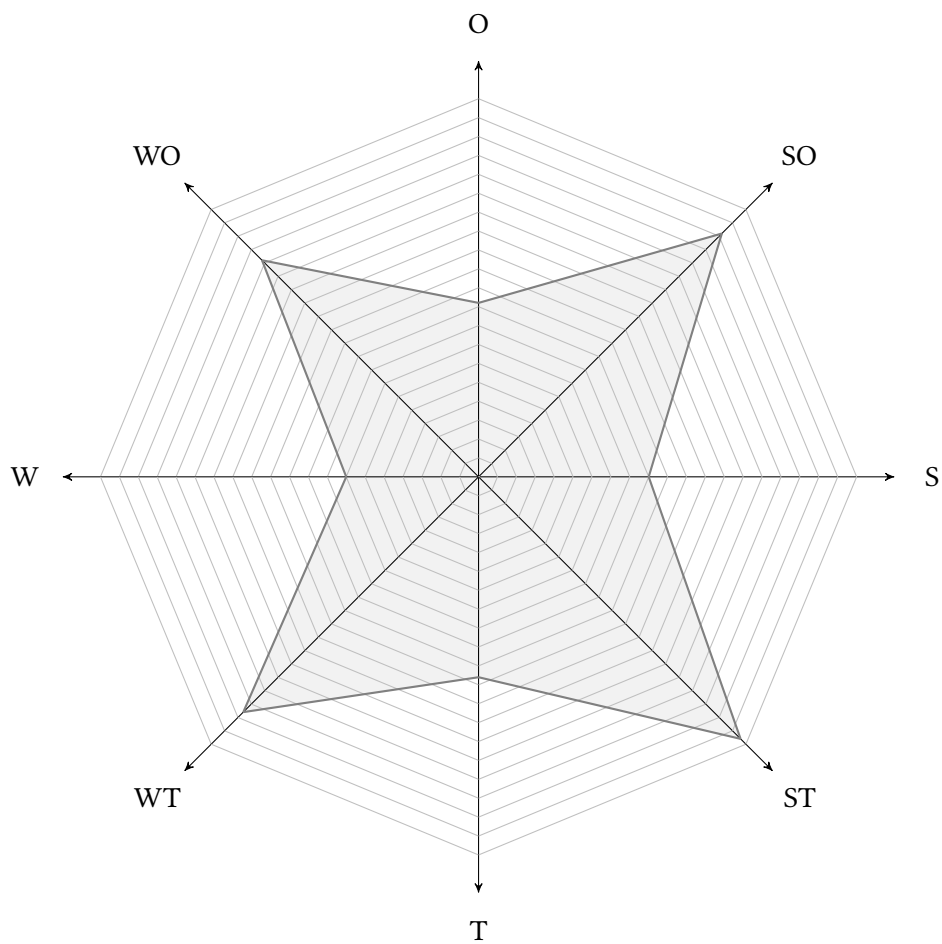

Figure 2.6: Kiviat diagram including weights of components and relevance of matrix quadrants for the SWOT analysis: COM reference scenario.

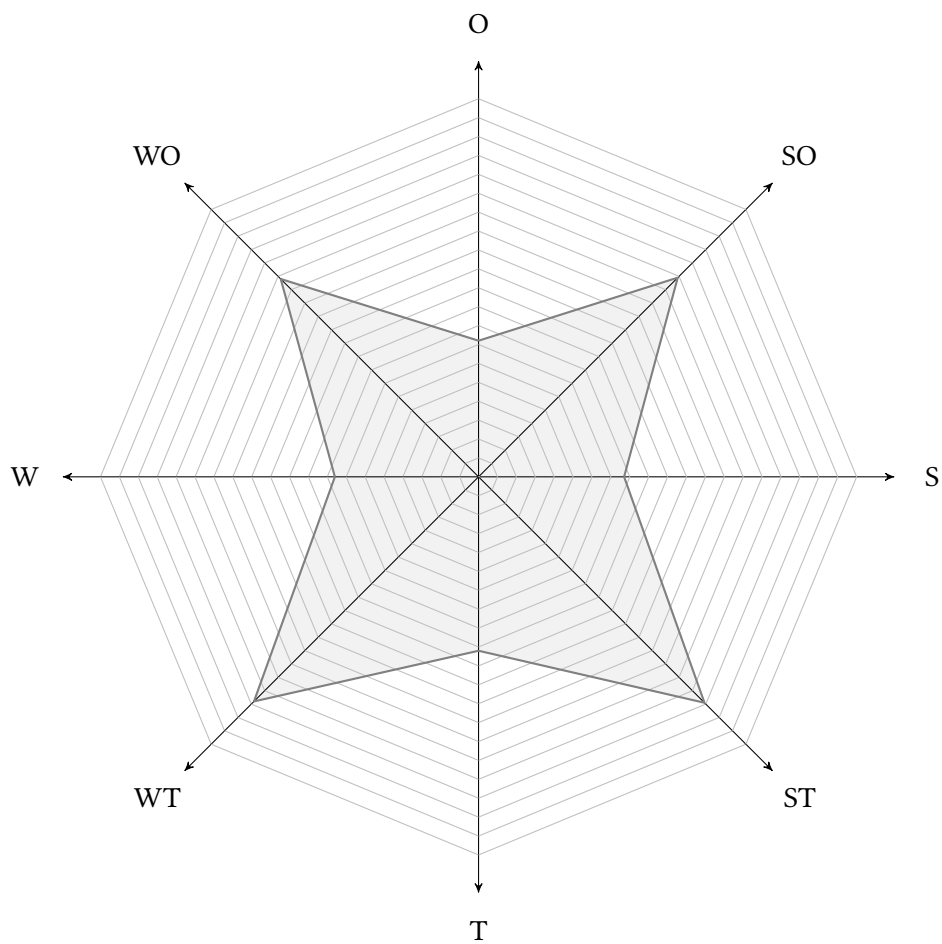

Figure 2.7: Kiviat diagram including weights of components and relevance of matrix quadrants for the SWOT analysis: MKT reference scenario.

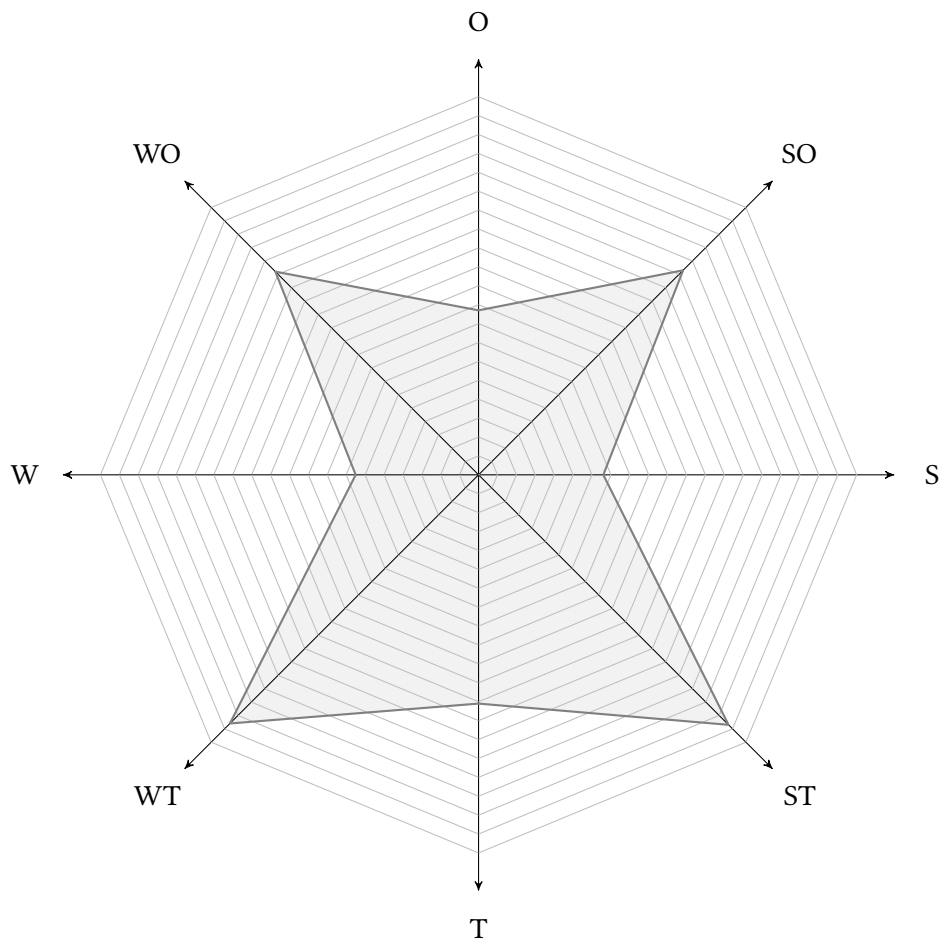

Figure 2.8: Kiviat diagram including weights of components and relevance of matrix quadrants for the SWOT analysis: PRIO reference scenario.

In the next section we propose some maxi-mini strategies and draw some conclusions from this work.

Table 2.7: The weights of variables per SWOT component.

Comp. (x)	Variable	Scenario	Weight ( $r_n$ )
Strengths	Flexible Spectrum Usage According to Regular User Needs	COM, MKT	2
	Incumbent Users Are Able to Resell Their Unused Spectrum	MKT	1
	Interference Protection for Incumbent Users with Double Check	COM, MKT	3
	QoS with Interference Protection for Secondary Users	MKT	1
	Prioritized Services and Interconnection	PRIO	2
	The Implementation and Management of Geo-Location Database	COM, MKT	2
	Competition and Innovation	COM, MKT, PRIO	1
	Transparent Market with Real-Time Information	MKT	1
	Flexibility in Building <i>on Demand</i> Networks	COM, MKT	1
	A Better Management of Costs: CAPEX Becomes OPEX	MKT	1
	Support from Broadcasters Due to Interference Limitation	COM, MKT, PRIO	2
Total			17
Weaknesses	Effective Real-Time Market: Pricing and Auction Modes	MKT	2
	Traditional Spectrum Market Is Easier to Implement	MKT	1
	Low Market Liquidity	MKT	2
	Rules Against Monopolization and Market Abuse	MKT	1
	Security: Authentication, Validation, and Blacklisting of Players	MKT	1
	Compute the TVWS Maps	COM, MKT	2
	Cross Border Issues in Interference Control and Spectrum Harmonization	COM, MKT, PRIO	2
	<i>Hidden Node Problem</i>	COM, MKT, PRIO	2
	Communication With the Geo-Location Database and Location Accuracy	COM, MKT	1
Total			14
Opportunities	TVWS Stability	COM, MKT, PRIO	2
	Geographical Dependence of TVWS	COM, MKT, PRIO	2
	Service Availability and Broadband Services in Remote Areas	COM, MKT, PRIO	1
	Coverage and Enhanced Indoor Services	COM, MKT, PRIO	1
	Simplifying Spectrum Trading and Positive Examples from Other Countries	MKT	1
	Super Wi-Fi Concept Proposed by FCC	COM	2
	Backhaul over TVWS	MKT, PRIO	1
	The Needs of Bandwidth over the Next Years	COM, MKT	2
	More Efficient Use of Electromagnetic Spectrum	MKT	1
	Technological Flexibility: Duplex Mode, Carrier Aggregation, and Femtocells	COM, MKT, PRIO	1
Standardization Bodies	COM, MKT, PRIO	2	
Total			16
Threats	Inertia in the Adoption of New Solutions	COM, MKT, PRIO	1
	Low Availability of TVWS	COM, MKT, PRIO	3
	Interference Negative Impact	COM, MKT, PRIO	2
	Recent Auctions for 450 MHz, 800 MHz, and 900 MHz Bands	COM, MKT, PRIO	2
	Delays Caused by Regulators and National Authorities	COM, MKT, PRIO	1
	Dispute Resolution Mechanisms	MKT	1
	Price of Spectrum and Profitability	MKT	2
	Expected Price for WSDs	COM, MKT, PRIO	2
	Possibility of a Second Digital Dividend	COM, MKT, PRIO	3
Total			17

## 2.8. Conclusions

In this chapter we presented a suitable SWOT analysis for the use of TVWS in three reference scenarios mainly considering the European context. The analysis provided herein is very flexible, since with few changes it can be applied to different scenarios in the use of TVWS or other contexts/markets. For example, the analysis was performed for the model and each of the reference scenarios, but it could be done considering the combination of two scenarios. As such, it would be necessary to select the common variables within the scenarios under study and repeat the whole process explained in section 2.7.

In the present study, the most relevant quadrant is the strengths-threats (ST) or the management phase. This happens mainly because most of the important threats to our model are related with the absence of TVWS as the whole model relies on them, mainly because: (a) TVWS will not exist if they become part of the traditional market; (b) And TVWS are only available because incumbents, namely broadcasters, are not using them.

Regulators, TV broadcasters, and mobile operators are accustomed to a traditional spectrum market, where only strongly positioned players are able to go for auctions and where the leased rights are for long periods of time. Moreover, as common sense, in traditional spectrum markets, players are in the safe place because they are protected from harmful interference.

Therefore, the TVWS defenders shall focus on the promotion of a real-time secondary spectrum market, where through the correct implementation of policies for protection ratios and with the safe harbor concept, incumbents are protected against interference.

Also important is to stimulate the development of innovative business models such that important TV stakeholders, like broadcasters and mobile operators will make part of a valuable chain, thus encouraging regulators to develop supportive policies for the functioning of secondary spectrum markets.

Moreover, our model promotes the spectrum democratization, either with or without QoS guarantees, where all players can afford it. Furthermore, new business opportunities like managing the broker or the geo-location database may be real. All of this would make the spectrum business even more profitable.

Finally, SWOT analysis is prone to suffer from subjective bias [98] and as such should be complemented by other strategic analysis tools like, for instance, the Porter's Five Forces model [99], [100] or Analytic Hierarchy Process (AHP) [101] that can confirm its conclusions.



## CHAPTER 3

---

### Techno-Economic Evaluation for TVWS

---

Evaluating the deployment of a Long Term Evolution (LTE) network over Television White Spaces (TVWS) (700 MHz) against the legacy (2.60 GHz) carrier frequencies in terms of costs, Capital Expenditure (CAPEX) and Operational Expenditure (OPEX), and the Net Present Value (NPV) figure, is essential to convince operators to support/adopt a more flexible spectrum market approach. The evaluation performed in this chapter is done for a period of five years and considers as an example the city of Munich in Germany and its metropolitan area; formally a square of  $50 \times 50$  km. Moreover, three different network deployment scenarios are taken into consideration: only with the 2.60 GHz legacy carrier (scenario 1), only with the 700 MHz TVWS carrier (scenario 2), and using the legacy carrier plus an additional TVWS carrier (scenario 3). The sensitivity analysis (NPV variance or profitability) to the change of input parameters in those three different network deployments is also done. Those changes are related with clients base, price of devices and device subsidies, Average Return Per User (ARPU), optical fiber infrastructure, cost of spectrum in traditional and secondary markets, and average use of TVWS. Results show that while being more profitable to buy spectrum in traditional market and follow the deployment scenario 2, the combination of legacy carrier and TVWS carrier (acquired through the secondary spectrum market), i.e., deployment scenario 3, closely follows the best result. Moreover, the profitability is very sensitive to ARPU and less sensitive to, e.g., price of devices or spectrum.

#### 3.1. Methodology for Network Techno-Economic Evaluation

The economic metric used for techno-economic evaluation is the NPV since it is one of the most widely used and reliable indicators to evaluate the feasibility of a project. Hence, in order to compute the NPV we must clearly understand what are the revenues and costs. The scenario we consider is of a single operator (in which there is no renting income). In this case, revenues are only the sum of all payments done by clients considering the services they have contracted.

The costs of building and running a broadband network can be divided into CAPEX and OPEX. CAPEX includes the investments in the network infrastructure and devices, as well as the hardware required for Operational & Maintenance (O&M) functions, such as network management and billing/charging systems. OPEX includes the labor costs and expenses originated from running and managing the network as well as costs related to, for example, marketing, sales, and clients care.

As an example, consider that we want to buy a new car. The CAPEX is, e.g., the money paid to the seller, either paid all at once or by paying a fixed amount per month, plus the money to buy a garage to park the car. On the other hand, OPEX can be considered as the money in renting the garage, to pay for the general maintenance and car repair, plus the money spent for filling the car tank with fuel and replacing the wheels.

The OPEX related with a certain project is often more difficult to predict than the CAPEX. This is especially true when new technologies are considered, as the previous experience and/or data are not available.

When revenues, investments, and all operational costs are estimated for each year of the period under study ( $N$  years), the cash flow  $CF(n)$ ,  $n \in \{0, 1, \dots, N\}$ , can be established

$$CF(n) = \text{Revenues}(n) - \text{CAPEX}(n) - \text{OPEX}(n). \quad (3.1)$$

The time-value of money and risks are taken into account in the discount rate  $r$  (sometimes also referred as interest rate). Therefore, the discounted cash flow is defined as

$$\text{DCF}(n) = \frac{CF(n)}{(1+r)^n}. \quad (3.2)$$

Finally, the sum of all discounted cash flows is known as the NPV,

$$\text{NPV} = CF(0) + \sum_{n=1}^N \text{DCF}(n) = \sum_{n=0}^N \text{DCF}(n). \quad (3.3)$$

The NPV<sup>1</sup> is a measure of the value of a project. Putting it simply, if NPV is positive the investment adds value to the company and the project is profitable; while for the opposite, i.e., if NPV is negative, the investment subtracts value from the company and the project shall be abandoned or reformulated; finally, if NPV equals zero then the investment neither gains nor loses value for the company, thus in this case the final decision shall be based on other criteria, e.g., strategic position. In [103] the decision criteria is further explained based on the analysis of project risks.

Hence, the NPV rule states that a company should invest in any project with a positive NPV, and since it incorporates the discount rate, it represents the expected return that is forgone by investing in the project rather than in comparable financial securities. Other methods, such as Internal Rate of Return (IRR) rule or the payback rule, also used in profitability assessment, have some pitfalls and deficiencies [104] when compared with the NPV method, and therefore are not used.

Additionally, the first year or year of implementation ( $y_0$ ) is mainly dealt with investments. As such, the  $CF(0)$  is expected to be negative; for educational purposes,  $CF(0)$  is commonly placed to the left of the sum to emphasize its role as (minus) the investment.

### 3.1.1. Scenario Description

For a comparative study on expenditures of deploying and operating a LTE network over TVWS (700 MHz) against the legacy (2.60 GHz) carrier frequencies, it is required the knowledge about the scenario where the LTE network will be deployed. In this context, we present the characterization of the area under study in terms of occupied area, population density, clients base, and number of active users. Also, we consider a LTE network with its main entities, and also a spectrum broker and the geo-location database.

<sup>1</sup> For more information about the historical use of NPV, see [102].

## Geographical Area and Population

The area for evaluation is a square of  $50 \times 50$  km around the city of Munich in Germany, which includes its metropolitan area. The red square in figure 3.1 shows the different zones that were considered: Munich (center), Ebersberg, Erding, Munich (district), Freising, and Dachau. The choice of Munich is related with its ability to characterize a typical European city (nevertheless, this study can be performed for any other city).

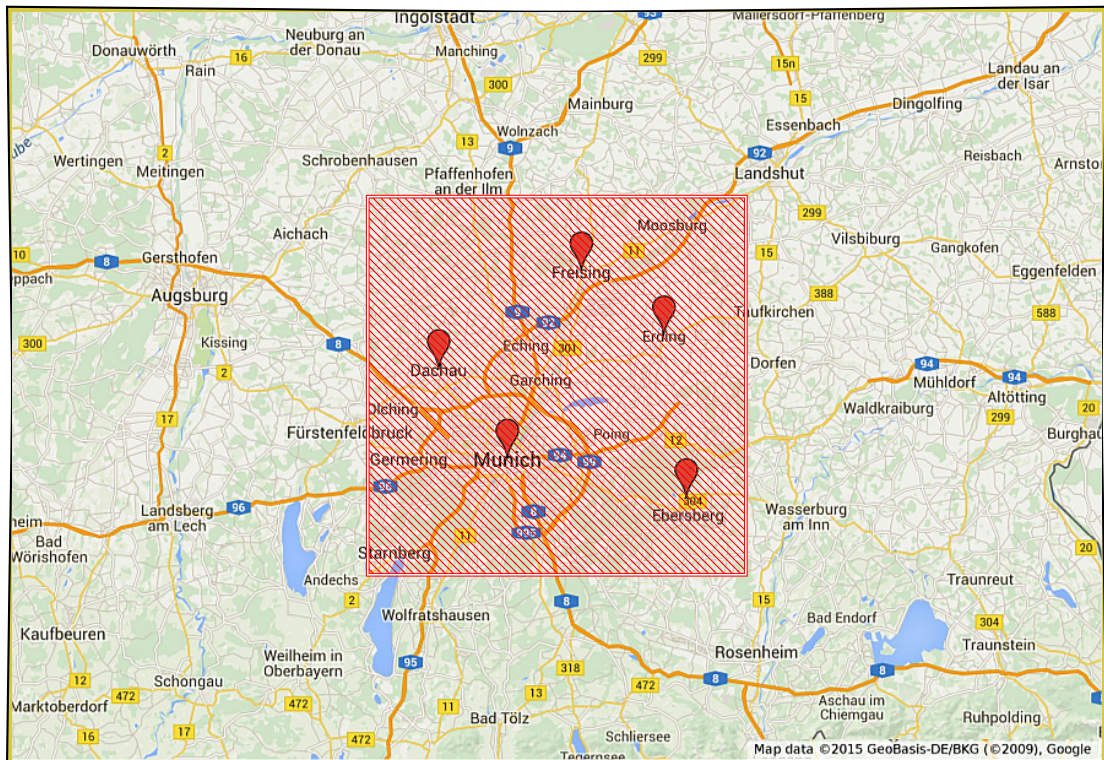

Figure 3.1: Munich area under consideration.

In table 3.1 the most relevant information about each zone for network planning is presented, namely, occupied area, population density, clients base, and number of active users. The population density is very important to classify areas as urban, sub-urban, and rural. Therefore, it provides the basis for projecting the likely number of users in different areas, which is shown in the table as the percentage of clients and active users according to the estimates made in [105].

These parameters are in turn used as input to determine the required network elements to meet coverage, capacity, and quality objectives for the different offered services<sup>2</sup>.

<sup>2</sup> Note that in the calculations regarding the number of clients, the migratory movement of people (which is difficult to predict) is not considered.

Table 3.1: Characterization of the area under consideration.

Region	Borough	Area (km <sup>2</sup> ) <sup>†</sup>	Population <sup>‡</sup>	Density (population/km <sup>2</sup> )	Clients (%) <sup>‡</sup>	Active users (%) <sup>*</sup>	Number of users
Munich (center)	Altstadt-Lehelv (1)	3.16	18 876	5973	18	5	170
	Ludwigsvorstadt-Isarvorstadt (2)	4.39	45 736	10 418	18	5	412
	Maxvorstadt (3)	4.29	46 058	10 736	18	5	415
	Schwabing-West (4)	4.37	59 553	13 628	18	5	536
	Au-Haidhausen (5)	4.22	54 382	12 887	18	5	489
	Sendling (6)	3.94	37 146	9428	18	5	334
	Sendling-Westpark (7)	7.81	50 903	6518	18	5	458
	Schwanthalerhöhe (8)	2.07	26 103	12 610	18	5	235
	Neuhausen-Nymphenburg (9)	12.92	84 604	6548	18	5	761
	Moosach (10)	11.09	47 754	4306	18	5	430
	Milbertshofen-Am Hart (11)	13.37	66 992	5011	18	5	603
	Schwabing-Freimann (12)	25.67	62 430	2432	18	5	562
	Bogenhausen (13)	23.71	75 657	3191	18	5	681
	Berg am Laim (14)	6.31	39 009	6182	18	5	351
	Trudering-Riem (15)	22.45	53 915	2402	18	5	485
	Ramersdorf-Perlach (16)	19.90	102 689	5160	18	5	924
	Obergiesing (17)	5.71	47 007	8232	18	5	423
	Untergiesing-Harlaching (18)	8.06	48 075	5965	18	5	433
	Thalkirchen-Obersendling-Forstenried- Fürstenried-Solln (19)	17.75	80 701	4547	18	5	726
	Hadern (20)	9.23	44 993	4875	18	5	405
	Pasing-Obermenzing (21)	16.50	63 763	3864	18	5	574
	Aubing-Lochhausen-Langwied (22)	34.06	37 857	1111	18	5	341
	Allach-Untermenzing (23)	15.45	27 730	1795	18	5	250
	Feldmoching-Hasenberg (24)	28.71	54 245	1889	18	5	488
	Laim (25)	5.29	50 082	9467	18	5	451
Subtotal		310.43	1 326 260	159 175			11 936

*continues...*

Ebersberg	Ebersberg	40.84	11 394	279	18	3	62
	Grafing	29.57	12 865	435	18	3	69
	Anzing	16.19	3583	221	18	3	19
	Aßling	31.38	4299	137	18	1	15
	Baiern	19.96	1513	76	18	1	5
	Bruck	21.60	1167	54	18	1	4
	Egmating	19.16	2142	112	18	1	8
	Emmering	17.22	1440	84	18	1	5
	Forstinning	12.26	3505	286	18	3	19
	Frauenneuharting	22.68	1475	65	18	1	5
	Glonn	30.24	4439	147	18	1	16
	Hohenlinden	17.32	2822	163	18	1	10
	Kirchseeon	17.91	9593	536	18	3	52
	Markt Schwaben	10.87	11 911	1096	18	5	107
	Moosach	18.21	1461	80	18	1	5
	Oberpframmern	18.47	2188	118	18	1	8
	Pliening	22.80	5159	226	18	3	28
	Poing	12.89	13 425	1042	18	5	121
Steinhöring	36.29	3912	108	18	1	14	
Vaterstetten	34.18	22 070	646	18	3	119	
Zorneding	23.77	8836	372	18	3	48	
Subtotal	473.81	129 199	6281			741	

*continues...*

Erding	Dorfen	99.60	13 723	138	18	1	49
	Erding	54.64	34 514	632	18	3	186
	Berglern	19.89	2568	129	18	1	9
	Bockhorn	47.15	3542	75	18	1	13
	Buch am Buchrain	22.75	1412	62	18	1	5
	Eitting	35.63	2415	68	18	1	9
	Finsing	23.17	4319	186	18	1	16
	Forstern	15.38	3254	212	18	3	18
	Fraunberg	42.37	3354	79	18	1	12
	Hohenpolding	27.42	1476	54	18	1	5
	Inning am Holz	11.83	1439	122	18	1	5
	Isen	43.78	5293	121	18	1	19
	Kirchberg	17.09	920	54	18	1	3
	Langenpreising	27.49	2640	96	18	1	10
	Lengdorf	33.90	2743	81	18	1	10
	Moosinning	39.96	5521	138	18	1	20
	Neuching	19.66	2411	123	18	1	9
	Oberding	64.70	5384	83	18	1	19
	Ottenhofen	10.27	1843	179	18	1	7
	Pastetten	22.05	2478	112	18	1	9
	Sankt Wolfgang	46.32	4312	93	18	1	16
	Steinkirchen	18.08	1153	64	18	1	4
	Taufkirchen (Vils)	70.18	8980	128	18	1	32
Walpertskirchen	18.45	2067	112	18	1	7	
Wartenberg	17.88	4783	268	18	3	26	
Wörth	21.05	4467	212	18	3	24	
Subtotal	870.69	127 011	3620			542	

*continues...*

Munich (district)	Garching	28.16	15 860	563	18	3	86
	Unterschleißheim	14.93	26 416	1769	18	5	238
	Aschheim	28.04	7665	273	18	3	41
	Aying	44.98	4499	100	18	1	16
	Baierbrunn	7.21	2944	408	18	3	16
	Brunnthal	26.92	4765	177	18	1	17
	Feldkirchen	6.41	6389	997	18	3	35
	Gräfelfing	9.58	12 870	1343	18	5	116
	Grasbrunn	23.59	6411	272	18	3	35
	Grünwald	7.63	11 057	1449	18	5	100
	Haar	12.90	19 430	1506	18	5	175
	Hohenbrunn	16.82	8954	532	18	3	48
	Höhenkirchen-Siegertsbrunn	15.19	9803	645	18	3	53
	Ismaning	40.19	15 389	383	18	3	83
	Kirchheim	15.51	12 463	804	18	3	67
	Neubiberg	5.77	13 938	2416	18	5	125
	Neuried	9.63	8411	873	18	3	45
	Oberhaching	26.60	12 939	486	18	3	70
	Oberschleißheim	30.60	11 296	369	18	3	61
	Ottobrunn	5.53	20 105	3636	18	5	181
	Planegg	10.68	10 415	975	18	3	56
	Pullach	7.41	8733	1179	18	5	79
	Putzbrunn	11.17	6035	540	18	3	33
	Sauerlach	48.49	7128	147	18	1	26
Schäftlarn	16.71	5564	333	18	3	30	
Straßlach-Dingharting	28.34	2963	105	18	1	11	
Taufkirchen	22.02	17 868	811	18	3	96	
Unterföhring	12.80	9931	776	18	3	54	
Unterhaching	8.73	22 774	2609	18	5	205	
Subtotal	542.54	323 015	26 477			2197	

continues...

Freising	Freising	88.45	45 223	511	18	3	244
	Moosburg	43.86	17 554	400	18	3	95
	Allershausen	26.56	5015	189	18	1	18
	Attenkirchen	16.16	2674	165	18	1	10
	Au in der Hallertau	54.99	5615	102	18	1	20
	Eching	37.83	13 275	351	18	3	72
	Fahrenzhausen	37.64	4624	123	18	1	17
	Gammelsdorf	21.63	1578	73	18	1	6
	Haag an der Amper	21.70	2869	132	18	1	10
	Hallbergmoos	35.06	9266	264	18	3	50
	Hohenkammer	25.74	2299	89	18	1	8
	Hörgertshausen	21.47	1904	89	18	1	7
	Kirchdorf an der Amper	32.99	2752	83	18	1	10
	Kranzberg	39.50	4011	102	18	1	14
	Langenbach	26.89	3910	145	18	1	14
	Marzling	20.50	3099	151	18	1	11
	Mauern	24.14	2780	115	18	1	10
	Nandlstadt	34.31	4977	145	18	1	18
	Neufahrn bei Freising	45.51	19 046	419	18	3	103
	Paunzhausen	12.73	1555	122	18	1	6
Rudelzhausen	40.82	3202	78	18	1	12	
Wang	31.19	2462	79	18	1	9	
Wolfersdorf	26.01	2414	93	18	1	9	
Zolling	34.59	4271	123	18	1	15	
Subtotal	800.27	166 375	4145				787

*continues...*



Dachau	Dachau	34.85	42 506	1220	18	5	383
	Altomünster	75.79	7405	98	18	1	27
	Bergkirchen	59.99	7195	120	18	1	26
	Erdweg	36.03	5595	155	18	1	20
	Haimhausen	26.73	4893	183	18	1	18
	Hebertshausen	29.60	5321	180	18	1	19
	Hilgertshausen-Tandern	28.64	3158	110	18	1	11
	Karlsfeld	15.55	18 293	1176	18	5	165
	Markt Indersdorf	68.60	9377	137	18	1	34
	Odelzhausen	30.48	4312	141	18	1	16
	Petershausen	32.82	6110	186	18	1	22
	Pfaffenhofen an der Glonn	20.90	1805	86	18	1	6
	Röhrmoos	31.74	6281	198	18	1	23
	Schwabhausen	30.23	6199	205	18	3	33
	Sulzemoos	19.04	2668	140	18	1	10
Vierkirchen	19.39	4278	221	18	3	23	
Weichs	18.72	3151	168	18	1	11	
Subtotal		579.10	138 547	4725			846
Total		3576.84	2 210 407	204 424			17 048

<sup>†</sup> The geographical area and population information is as in the latest demographical report (census) available for the year 2012.

<sup>‡</sup> The number of clients for a given operator (market sharing) is intrinsically related with its market position against competitors for the area under consideration. This value is for the first year of deployment.

\* The number of active users is given accordingly with the geographical classification. As such, for urban, sub-urban, and rural areas, respectively, 5, 3, and 1 % of the clients are active [105], which is used as input for coverage and capacity planning.

From the geographical and population input information, the population density and the geographical classification are defined, which is needed in order to start the coverage (e.g., selection of propagation models) and capacity (e.g., number of active users) dimensioning exercises. More specifically, the area is considered rural, when the population density is lower than 200 people/km<sup>2</sup>, sub-urban when population density is from 200 to 1000 people/km<sup>2</sup>, while it is considered urban when the population density is bigger than 1000 people/km<sup>2</sup>.

The classification presented herein follows a simple rule, however giving an absolutely objective criteria to classify a geographical area into urban, sub-urban, and rural zones is probably impossible, because any method requires a choice of thresholds, which is subjective to a certain extent. Nevertheless, the combination of other criteria may be used instead [106], [107]. Figure 3.2 depicts the Munich area and the geographical classification for each zone.

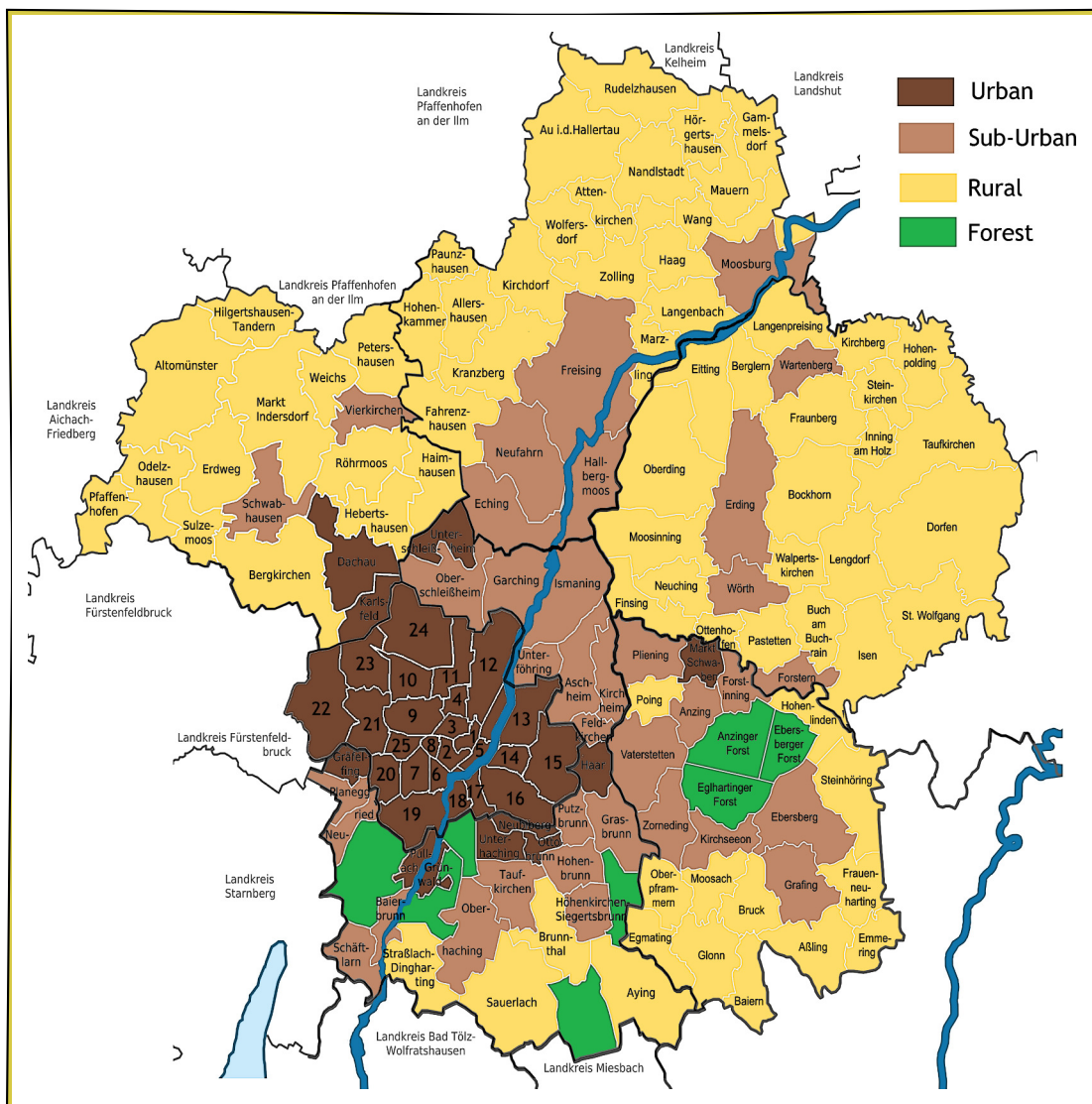

Figure 3.2: Munich area with the geographical classification per zone.

### System Overview

In figure 3.3 the LTE network with additional TVWS entities is shown. Herein, we skip a detailed explanation about those elements and focus on how they are integrated in our

evaluation. A detailed description about LTE systems and the functionalities of each of its network nodes may be found in [108]. In the same manner, details about spectrum broker and geo-location database are presented in chapter 2 or in [24]. However, it is important to highlight that the implementation of a flexible spectrum market is based on the premise that regulators adopt unambiguous rules, which set out clearly the rights and obligations of incumbents and any secondary system that use TVWS on a licensed basis. Also, the use of a spectrum broker limits the possible generated interference both in primary and secondary systems.

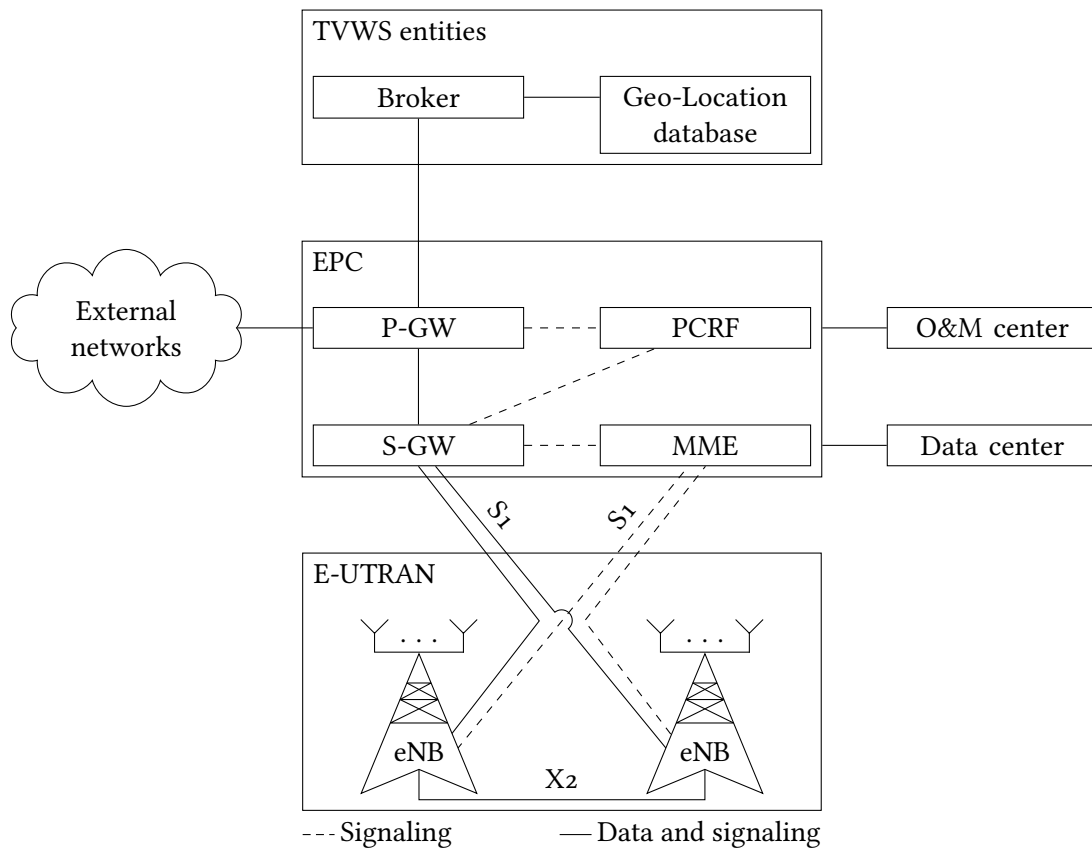

Figure 3.3: LTE network with additional TVWS entities for a flexible spectrum market.

The LTE systems can be divided, as in any cellular network, into access network, transport network, and core network. The access network, or Evolved Universal Terrestrial Radio Access Network (E-UTRAN), is considered to be only constituted by the Base Stations (BSs) or Evolved Node Bs (eNBs) (using LTE terminology) that are connected through the X2 interface, and it is the medium between clients and all the other network entities. The transport network is the connection element, through the S1 interface, between the access network and the core network. It delivers the data or control packets, and for this chapter we considered it to be optical fiber<sup>3</sup>. The core network, or Evolved Packet Core (EPC), is the central part of the whole network and provides various services for clients who are connected by the access network, such as packet routing, mobility management, authentication, accounting, and access to external networks. The EPC is, in a general sense, constituted by the Mobility Management Entity (MME), Policy and Charging Rules Function (PCRF), Service Gateway (S-GW), and Packet Gateway (P-GW). Other network entities, like a data center, with various types of databases where, e.g., the profiles of clients are stored, and the O&M center, also complete the LTE network.

<sup>3</sup> The use of optical fiber is reasonable for dense populated cities. However, in rural places the use of microwave links may be seen as an alternative choice.

The EPC may be limited by two factors: first, the number of BSs that can be connected to a single MME; second, the amount of traffic that can be processed at the same time by the S-GW and P-GW. It is assumed that if a new pair of S-GW and P-GW is required, then a new EPC is required. However, in many cases, a new MME is not required because it only processes control information and can handle a large amount of connected BSs.

Moreover, the BSs are connected to each other through the X2 interface, which mostly carries control information, and may be seen as a logical link. Practically speaking, and assuming the delay in the transport network can be neglected, the X2 interface can be implemented through the core network and multiplexed in only one optical fiber. Therefore, from each BS to the core network we only assume one optical fiber link, which has enough capacity to deliver all the traffic that comes and goes from the BS to the core network and vice-versa.

Finally, the costs associated with the broker and geo-location database (either investments or running costs) are not considered. However, if they were considered and since the number of such elements do not scale with the network size, their impact would be the same in all three different network deployments, and for comparative studies the related gains/losses would not change.

### 3.2. Network Infrastructure

The network planning is performed to determine the number of BSs that are needed (both in terms of coverage and capacity) to serve a certain region (i.e., satisfy users' throughput demands). The number of BSs has a direct influence on the costs for operators because, apart from the direct costs associated with BSs (equipment, antennas, renting sites, cooling systems, etc.), it is also used to calculate the length of optical fiber infrastructure to connect the access and core networks. Moreover, the EPC is also limited by the number of connected BSs.

Herein, we are also interested in reducing the implementation and operational costs while maintaining the network performance, which may be achieved with the introduction of TVWS, because expectedly less BSs (thus less costs) are required for the same area; or with some increase in network costs, more capacity can be delivered.

Therefore, a radio network dimensioning tool for the area under consideration was employed. In [105] the planning process both in terms of coverage and capacity is detailed described: a flat network configuration, the percentage of clients and active users per geographical area, throughput per user, cell configuration, block rate, and pathloss models are the parameters taken into consideration; for consistence, further details are omitted herein, but may be easily found in the referred literature.

Hence, the radio network dimensioning aims basically to estimate the number of required BSs. The network dimensioning process is based on a uniform distribution of clients inside each borough, flat morphology, and a regular BS distribution.

The network planning activities, explained in the next paragraphs, are the following:

- Radio link budget;
- Coverage and capacity analysis;
- Required number of BSs.

### 3.2.1. Radio Link Budget

The radio link budget is an accounting of all the gains and losses in a transmission system. It looks at the elements that will determine the signal strength arriving at the receiver. The radio link budget includes the following items:

- Transmitter power;
- Antenna gains (receiver and transmitter);
- Antenna feeder losses (receiver and transmitter);
- Pathloss;
- Required Signal to Interference-plus-Noise Ratio (SINR).

With these parameters the maximum allowable pathloss for the required SINR is calculated, which can generally be written as

$$L = \text{Tx}_{\text{Power}} + \text{Tx}_{\text{Gain}} - \text{Tx}_{\text{Loss}} + \text{Rx}_{\text{Gain}} - \text{Rx}_{\text{Loss}} - \text{SINR}_{\text{Required}} - \text{Rx}_{\text{Noise}}. \quad (3.4)$$

Where:

- $L$  is the total pathloss between the transmitter signal to the receiver (in dB);
- $\text{Tx}_{\text{Power}}$  is the power transmitted by the transmitter antenna (in dBm);
- $\text{Tx}_{\text{Gain}}$  represents the gain of transmitter antenna related Equivalent Isotropically Radiated Power (EIRP) (in dBi);
- $\text{Tx}_{\text{Loss}}$  represents the transmitter losses (in dB);
- $\text{Rx}_{\text{Gain}}$  represents the gain of receiver antenna related EIRP (in dBi);
- $\text{Rx}_{\text{Loss}}$  represents the receiver losses (in dB);
- $\text{SINR}_{\text{Required}}$  is the minimum required SINR for the signal to be received at the receiver with the necessary quality/strength, which in LTE is closely related with Modulation and Coding Scheme (MCS) and service quality provisioning (in dB);
- $\text{Rx}_{\text{Noise}}$  is the noise power at receiver antenna (in dBm).

### 3.2.2. Coverage and Capacity Analysis

As explained in [105], the coverage planning gives an estimation of resources needed to provide service in the deployment area with the given system parameters, without any capacity concern. Therefore, it gives an assessment of the resources needed to cover the area under consideration so that the transmitters and receivers can communicate to each other. The coverage analysis fundamentally remains the most critical step in the design of any network.

Appropriate selection of propagation models is required for the coverage analysis and estimate the number of BSs needed to provide service in the deployment area. The cell radius of a particular LTE sector is calculated through the maximum allowable loss (maximum allowable pathloss using equation (3.4) plus the shadowing margin) both in Downlink (DL) (BS-user direction) and Uplink (UL) (user-BS direction) for the required SINR. Thereby, the maximum coverage range of a cell is the minimum between DL and UL calculations, which are obtained through the Erceg Extended model [109], [110] for the deployment in 2.60 GHz and the Okumura Hata model [111] for the deployment in 700 MHz.

The Erceg Extended model distinguishes three terrain categories, called A, B, and C. Category A is for a terrain with the highest pathloss (hilly terrain with moderate-to-heavy tree densities) and is used for urban areas. Category B characterizes flat terrains with intermediate pathloss condition or sub-urban areas. Category C is suitable for rural areas, where pathloss is the lowest (mostly flat terrain with light tree densities). Moreover, with appropriate frequency correction factors the model is “safely” used in the frequency range from 1 to 4 GHz. In its turn, the Okumura Hata model, while comprising the same morphologies as the previous model, is used in the frequency range from 150 to 1500 MHz. Thus, the propagation models are aligned with the network deployment and geographical classification considered for this chapter.

Also the required SINR considers the kind of provided services. For that, we project that all active users are served with a Constant Bit Rate (CBR) service of 1 Mbps in DL and 256 kbps in UL. After achieving the number of BSs to cover the area under consideration, the next step is to analyze the capacity issue.

Each BS is limited in its capacity, i.e., there is a maximum amount of traffic (throughput) that it can handle. In some wireless cellular systems, like LTE, coverage and capacity are interrelated. In such cases, the main indicator of capacity is the SINR distribution over the cell, which is obtained by performing physical level simulations in a LTE simulator [105], [112], [113]. The SINR distribution is directly mapped into system capacity, which is impacted by several factors, e.g., scheduler implementation, MCSs, antenna configuration/diversity, and interference levels.

As such, in order to map the inter-cell interference levels, different utilization factors per geographical area (0.85 for urban, 0.88 for sub-urban, and 0.9 for rural) were used<sup>4</sup> and the maximum throughput of a BS was calculated for the Single Input Single Output (SISO) antenna configuration, the system bandwidth of 5 MHz [114] in each direction (DL and UL), considering the highest LTE MCS [115], and that each BS had three sectors.

The number of BSs regarding the capacity is then the ceiling calculation of the number of users times the capacity of each user, divided by the capacity of each BS, divided by the number of sectors of each BS.

For network planning, the region under study was divided into boroughs and determined the number of BSs for each of them considering their population density. However, and mainly in rural areas, it may happen that the number of calculated BSs is higher than the required one. This is true because with this approach, at least one BS is required per borough. Although, it could happen that a neighbor BS had enough available capacity to accommodate more users and, therefore, a BS becomes surplus.

### 3.2.3. Required Number of BSs

The coverage and the capacity planning are of essential importance in the whole radio network planning. The coverage planning determines the service range, while the capacity planning determines the number of to-be-used BSs and their respective capacities. In this way, the main outcome of the network planning is the number of BSs to provide coverage and at the same time fulfill the projected quality objectives for the different offered services. Therefore, it is considered that the total number of BSs is calculated as the highest value between the coverage and capacity calculations, as detailed in section 3.2.2.

As an example, table 3.2 shows the different number of calculated BSs for the legacy and TVWS bands in Munich (center) for the first year. Clearly, the required number of BSs for

<sup>4</sup> The inter-cell interference is predictably higher in urban areas than in sub-urban or rural areas.

frequency 2.60 GHz is higher than in 700 MHz, which in principle would bring advantages to reduce both CAPEX and OPEX.

Table 3.2: Number of BSs for 2.60 GHz and 700 MHz in Munich (center) for the first year.

Region	Borough	Number of users <sup>†</sup>	Number of BSs	
			2.60 GHz	700 MHz
Munich (center)	Altstadt-Lehelv (1)	170	6	5
	Ludwigsvorstadt-Isarvorstadt (2)	412	14	12
	Maxvorstadt (3)	415	15	12
	Schwabing-West (4)	536	19	15
	Au-Haidhausen (5)	489	17	14
	Sendling (6)	334	12	10
	Sendling-Westpark (7)	458	16	13
	Schwanthalerhöhe (8)	235	8	7
	Neuhausen-Nymphenburg (9)	761	26	21
	Moosach (10)	430	15	12
	Milbertshofen-Am Hart (11)	603	21	17
	Schwabing-Freimann (12)	562	19	16
	Bogenhausen (13)	681	24	19
	Berg am Laim (14)	351	12	10
	Trudering-Riem (15)	485	17	14
	Ramersdorf-Perlach (16)	924	32	26
	Obergiesing (17)	423	15	12
	Untergiesing-Harlaching (18)	433	15	12
	Thalkirchen-Obersendling-Forstenried-Fürstenried-Solln (19)	726	25	20
	Hadern (20)	405	14	12
	Pasing-Obermenzing (21)	574	20	16
	Aubing-Lochhausen-Langwied (22)	341	12	10
	Allach-Untermenzing (23)	250	9	7
	Feldmoching-Hasenbergl (24)	488	17	14
	Laim (25)	451	16	13
Total		11 936	416	339

<sup>†</sup> The same information as in 8th column of table 3.1.

### 3.2.4. Core and Transport Network Dimensioning

In addition to the number of BSs, the network topology must also be considered. As it was previously mentioned, the interfaces X2/S1 (recall figure 3.3) are implemented through the core network, and both data and control information may be multiplexed in the same optical link. This is only true if the delay in the optical fiber can be neglected (when compared to the requirements of most demanding services, e.g., real-time services) and there is enough capacity in a single fiber to deliver all the traffic from the BS that is connected to the core network, and vice-versa. In fact, the area under study is a small area of  $50 \times 50$  km around a European metropolis, so the previous statement is expected to be true.

The total square area for evaluation may be divided into smaller squares. Each of those squares is named as EPC area and represents an area where all the BSs are connected to that

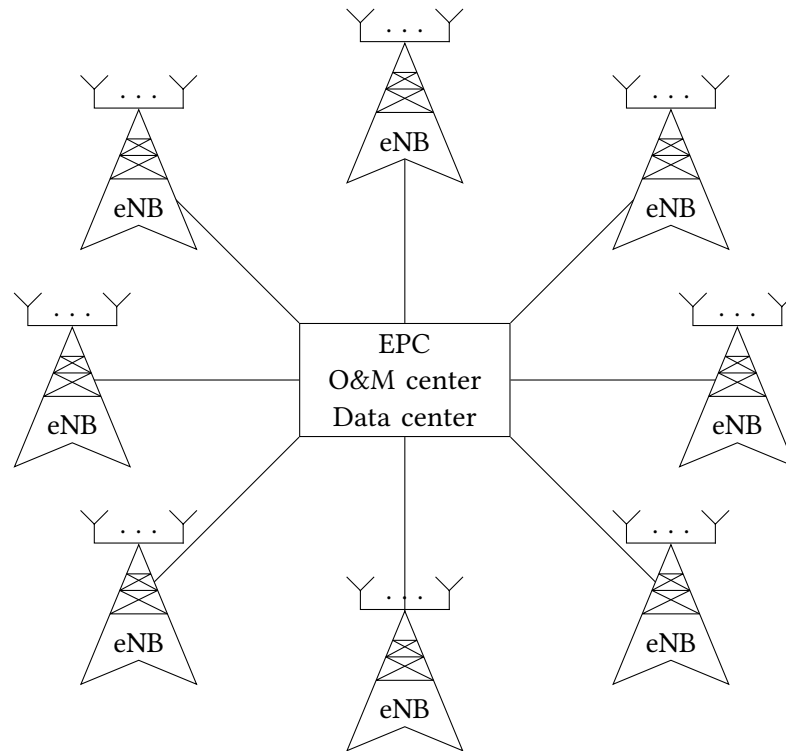

Figure 3.4: EPC area with star topology for the network under evaluation.

particular EPC, as in figure 3.4. Recall that EPCs may be limited by the number of BSs connected to a single MME or the traffic that can be processed at the same time by the S-GW and P-GW. Herein, those limits are adjusted from [116] and equal to 4000 BSs or 40 Gbps, which are aligned (same order of magnitude) with the values used in [117].

### 3.3. Deployment Costs

In section 3.2 we determined the number of network elements needed to fulfill coverage, capacity, and service quality objectives. In this section, we estimate the costs of each considered element. Some of the values (e.g., cost of traditional spectrum market, price of devices, or interest rate) are based on real values, while others (such as cost of optical fiber infrastructure, EPC, and BS) are found in literature [118], [119].

Hence, table 3.3 summarizes the most relevant parameters and their respective value as the reference for deployment scenarios 1 and 2.

Also, table 3.4 has the additional values for the deployment using the legacy carrier plus a TVWS carrier, i.e., deployment scenario 3. In both cases, these values are the starting reference to calculate the final NPV and also to start the sensitivity analysis.

As a complement to the values shown in tables 3.3 and 3.4, the (other) costs associated with the infrastructure of EPC and BSs, and O&M upgrades (hardware or software) are also considered. Finally, the price of TVWS carrier per day in the context of flexible spectrum market and its average use during the day (considering every day of the year) reflects the operator's necessity to overcome capacity faults, especially found during busy hours; the cost of the spectrum is based on the recent Portuguese spectrum auctions [74].



Table 3.3: Reference values for traditional spectrum market deployments at legacy and TVWS carrier frequencies.

Parameter	Value	Reference
Period of analysis ( $N$ )	5 years ( $y_0$ to $y_4$ )	
Clients base ( $y_0$ )	18 % (397 878 people)	[118]
Clients growth ( $y_1$ to $y_4$ ) <sup>†</sup>	80 %, 128 %, 179 %, 215 %	[118]
Price of devices ( $y_0$ to $y_4$ )	€80, €60, €40, €30, €20	
Device subsidies	50 %	[119]
ARPU	€13	
Price of spectrum (2.60 GHz, 700 MHz) <sup>‡</sup>	€3 million, €45 million	[74]
Price of optical fiber	€45 000/km	[119]
Fiber sharing factor <sup>*</sup>	50 %	[119]
Price of EPC	€50 000	[119]
Price of BS	€3500	[119]
Price of O&M and data centers <sup>§</sup>	€500 000	
Interest rate	5 %	

<sup>†</sup> In comparison with the first year of deployment ( $y_0$ ).

<sup>‡</sup> For a bandwidth pair of  $2 \times 5$  MHz. Also, despite of having three sectors per cell, only a carrier is paid, i.e., the same carrier is reused in all sectors.

<sup>\*</sup> In the optical fiber, control information and data are multiplexed. This percentage refers to the amount of fiber used for data.

<sup>§</sup> Information obtained from a Brazilian operator in a private document.

Table 3.4: Reference values for flexible spectrum market deployment using the legacy carrier plus an additional TVWS carrier.

Parameter	Value	Reference
Price of spectrum (2.60 GHz)	€3 million	[74]
Price of TVWS/day (urban, sub-urban, rural)	€411, €247, €164	[24]
BSs that have additional TVWS carrier (urban, sub-urban, rural) <sup>†</sup>	50 %, 30 %, 20 %	
Average use of TVWS during the day	4 hours	[24]
ARPU (increased by 10 %)	€14.30	
Price of BS (increased by 10 %)	€3850	[119]

<sup>†</sup> Values are based on the expectation that higher densely populated zones require more BSs with additional TVWS carrier.

### 3.4. Results and Discussion

In this section we present the results for the three different deployment scenarios:

- Deployment scenario 1: traditional spectrum market for deployment using only the legacy (2.60 GHz) carrier;
- Deployment scenario 2: traditional spectrum market for deployment using only the TVWS (700 MHz) carrier;
- Deployment scenario 3: flexible spectrum market for deployment using the legacy carrier plus an additional TVWS carrier.

The analysis is divided into the following aspects: NPV, costs (CAPEX and OPEX), and the sensitivity of NPV to the change of some input parameter. Hence, the basis for the whole analysis presented herein employs the values from tables 3.3 and 3.4, while equation (3.3) is used for the NPV calculation.

#### 3.4.1. NPV, CAPEX, and OPEX for Deployment Scenarios 1 and 2

In figure 3.5 we present the total NPV and the balance or cash flow (revenues minus costs) per year as in equation (3.1), for the total of five years of deployment. As it can be seen, for the first year, which is the year when most of the network is implemented, the balance is negative. More negative for the carrier frequency of 2.60 GHz than 700 MHz. For the other years, the balance is positive, which means that the total costs are less than the revenues on each particular year.

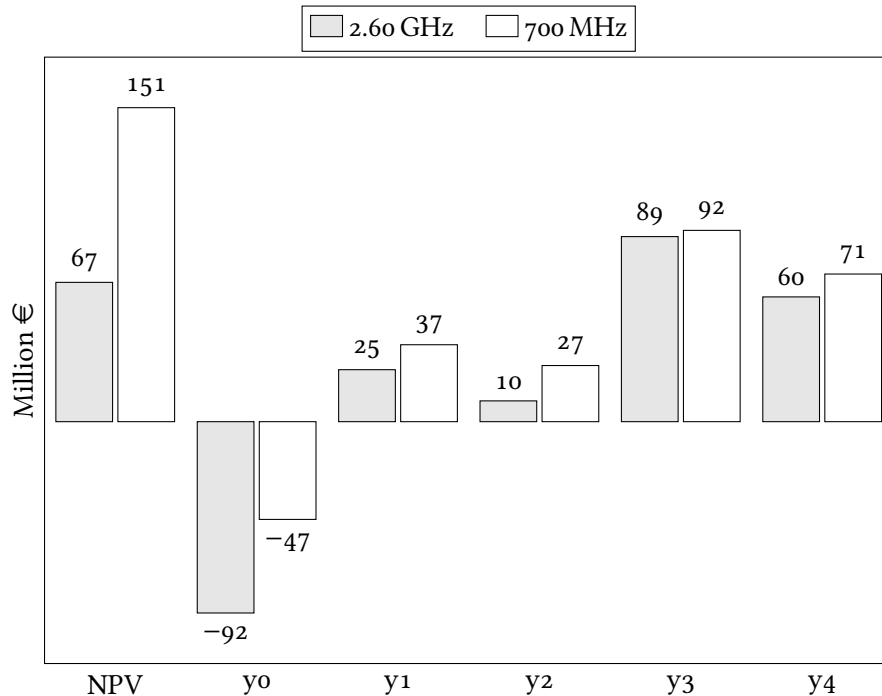

Figure 3.5: Total NPV and balance per year.

Regarding the contribution of each geographical area to the total NPV, the largest contribution comes from urban and sub-urban areas (see figure 3.6). This result was expected because in the square under evaluation the network is mainly limited due to capacity reasons and most of the people are located in urban and sub-urban areas.

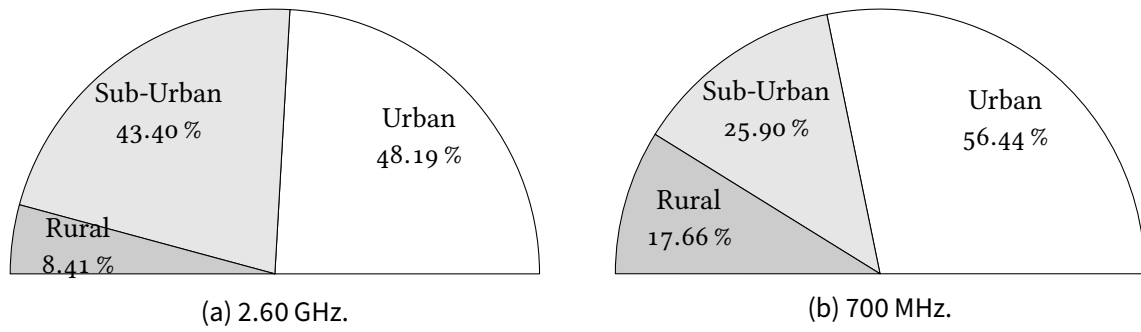

Figure 3.6: Contribution of each geographical area for the total NPV.

Now looking to the cumulative figures of the costs and revenues in figure 3.7(a), if we draw a line between the edges of the bars for the deployment using 2.60 GHz and, in the same manner, for the bars of 700 MHz (see figure 3.7(b)), it is easy to see that the line of 2.60 GHz is above the 700 MHz line, which means the costs are greater and, comparing the slopes, tend to increase more rapidly.

Moreover, if we do the same exercise for the revenues, we can see that its line crosses the 700 MHz line around the second year and the line of 2.60 GHz between the third and fourth years. Therefore, it is clear that an operator would recover its investment in one and half years earlier if it chooses to deploy the network in 700 MHz rather than in 2.60 GHz. Also, the slope in the line of revenues is greater than in any of the cost lines or, in other words, the revenues increase faster than the costs; that is, in both deployments the network will be profitable.

Furthermore, it is good to determine the main contributions for the deployment and operational costs, which is presented in figure 3.8 for CAPEX and in figure 3.9 for OPEX. Regarding the CAPEX, and contrary to what was expected, the impact of spectrum costs is not significant (only 0.27 % for 2.60 GHz and 5.51 % for 700 MHz). On the other hand, the cost of fiber represents around 90 % of the CAPEX. Thus, we can reduce the CAPEX if we are able to reduce the size of transport network. Regarding OPEX, the cost related with the management of optical fiber infrastructure reveals once again to be significant (around 28 % for 2.60 GHz and 23 % for 700 MHz); however, the costs with subsidies and replacement of devices represent the biggest portion of the OPEX (around 62 % for 2.60 GHz and 69 % for 700 MHz).

The previous results seem to give advantage to the 700 MHz frequency. However, results must be assessed regarding their sensitivity to the change of input parameters, as it is presented in the following paragraphs.

### 3.4.2. Sensitivity Analysis for Deployment Scenarios 1 and 2

The sensitivity analysis is performed in the following manner: the value of an input parameter is changed while the others remain the same and then we extract the value of NPV; that is the sensitivity of NPV to the change (increase or decrease) of that parameter. The sensitivity analysis is useful to determine the influence of each parameter in the final NPV and then establish strategies of deployment to mitigate or benefit from such influence.

In figure 3.10 the variation of NPV considering a reduction in clients base is presented. The reference (REF) values from table 3.3 are 397 878 people in  $y_0$  (referred as the first year or year of implementation), 716 187 people in  $y_1$ , 907 170 people in  $y_2$ , 1 110 883 people in  $y_3$ , and

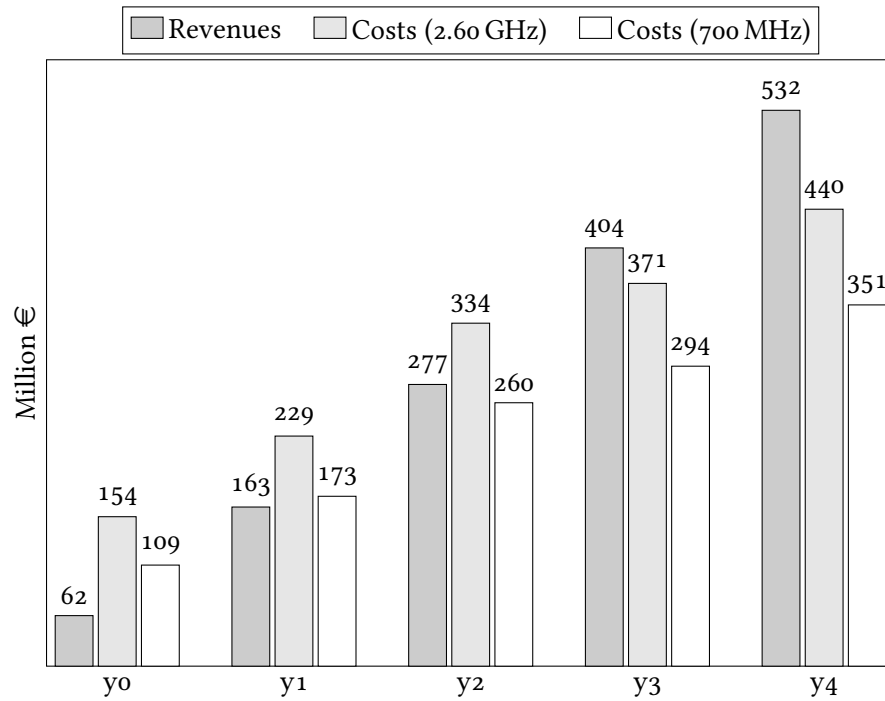

(a) Bar chart.

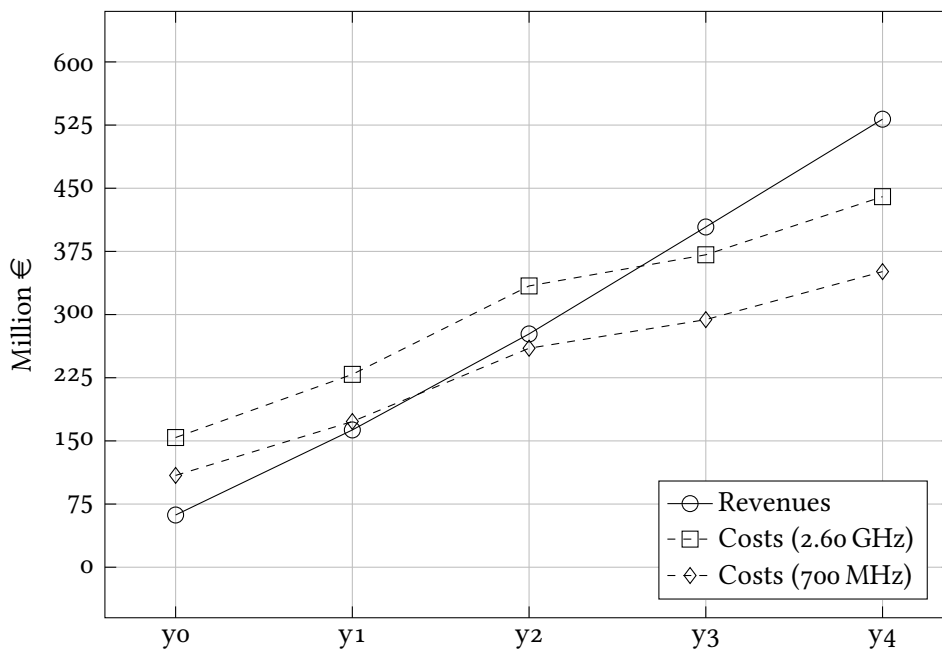

(b) Transition points.

Figure 3.7: Cumulative total revenues and costs per year.

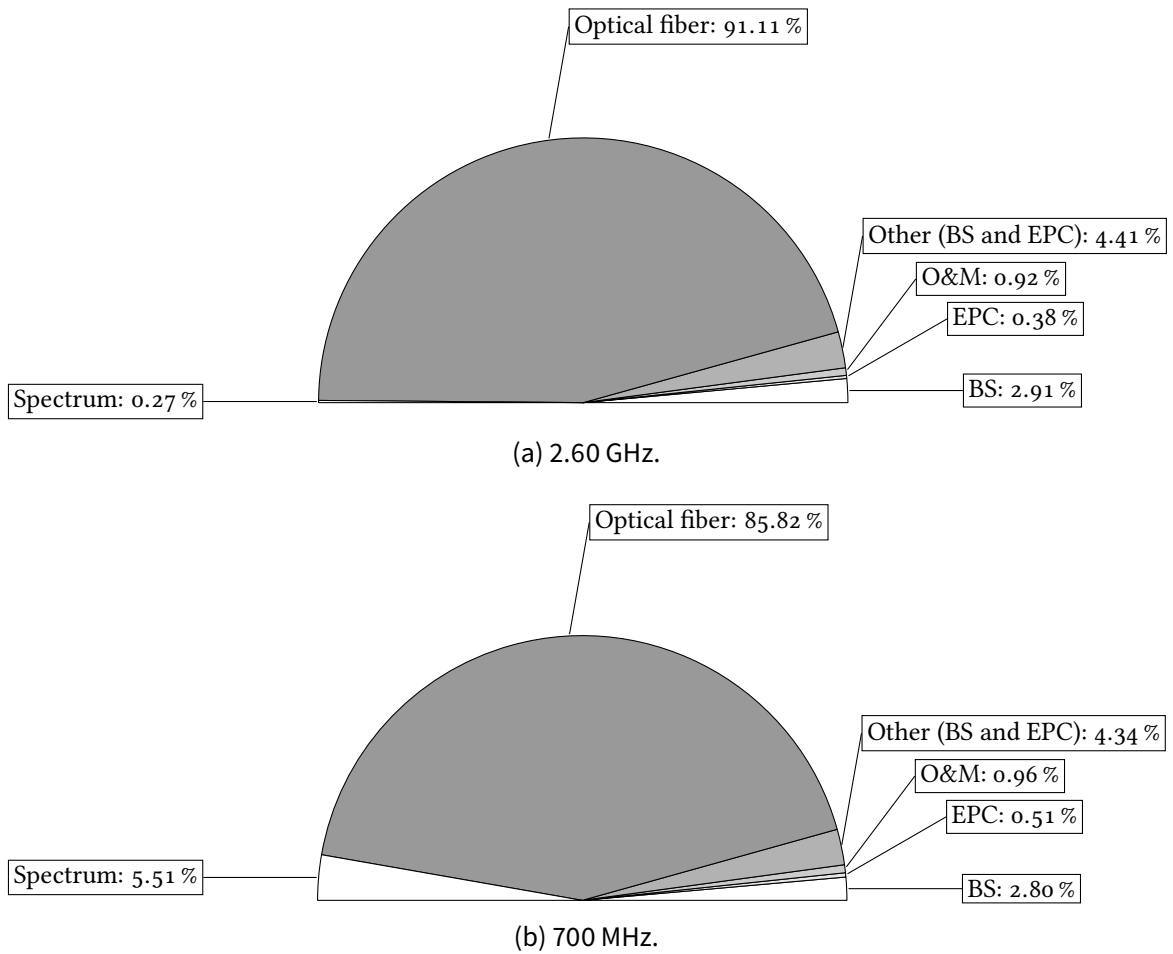

Figure 3.8: Contribution for the total CAPEX of each parameter.

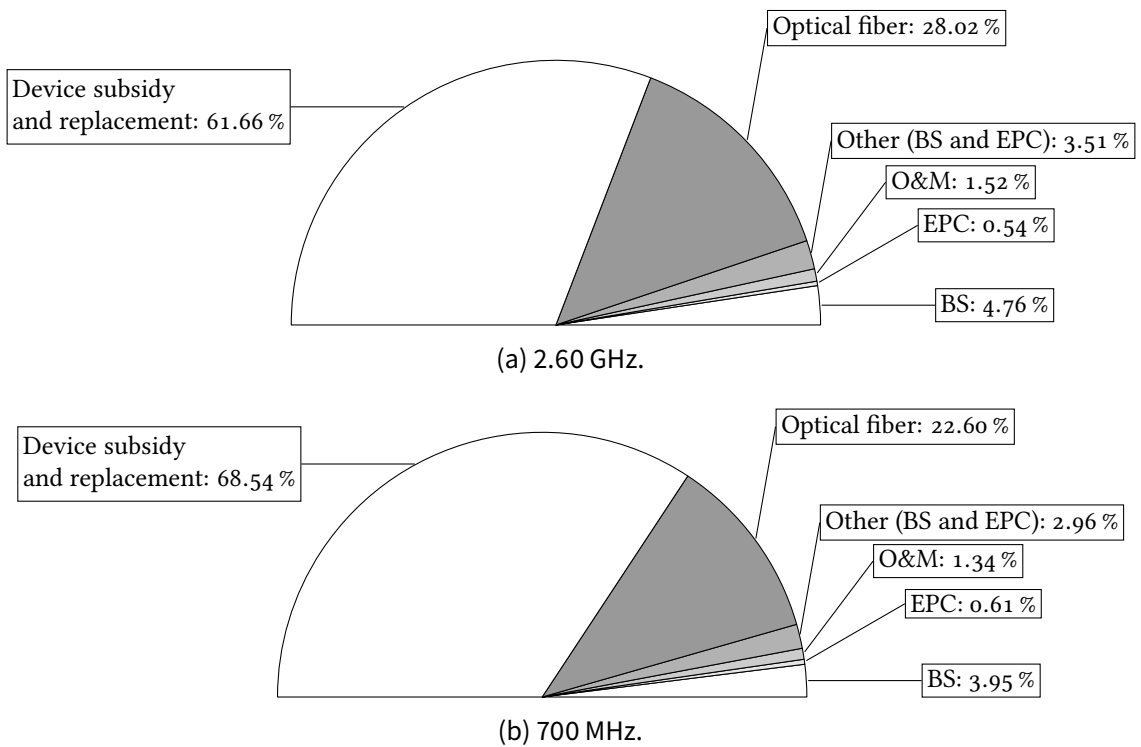

Figure 3.9: Contribution for the total OPEX of each parameter.

1 253 480 people in y4. The slope in both lines is high, which means that NPV is very sensitive to the reduction in clients base.

The higher slope presented in the reduction from 30 to 40 % in clients base is derived from the fact that with less clients the operator receives less revenues but, as explained in section 3.2.2, if there is at least one client per borough, one BS (and EPC) needs to be deployed to attend that client; and for a reduction of 40 % in the clients base, the NPV in 2.60 GHz is negative, i.e., the network becomes non-profitable.

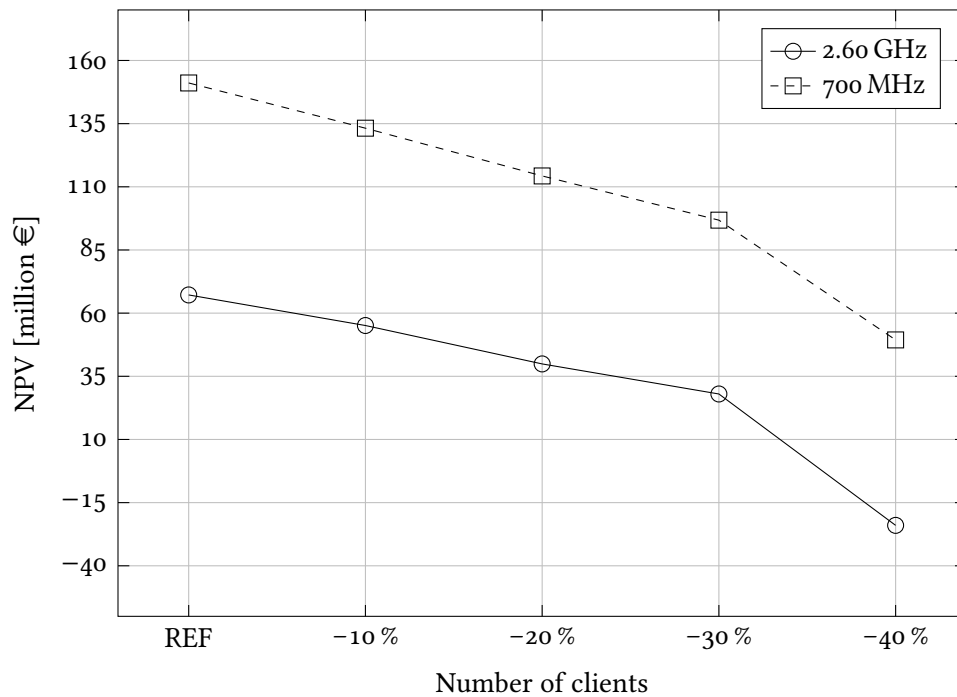

Figure 3.10: Total NPV variation by reducing the number of clients.

Figure 3.11 presents the NPV variation while increasing the price of devices. The REF values are €80 in y0, €60 in y1, €40 in y2, €30 in y3, and €20 in y4. Since the slope of the lines is not very high, the NPV is not very sensitive to the increase in the price of devices.

In figure 3.12 it is shown the variation of the total NPV to the increase in device subsidies that an operator gives to its clients. The REF value is 50 %. As can be seen, the slope of both lines is not very high, thus, the NPV is not very sensitive to the increase in the device subsidies. Nevertheless, it reveals to be more sensitive than to the increase in price of devices.

In figure 3.13 the variation of NPV to the reduction in ARPU is shown. The REF value is €13. For this case, the slope of the lines is very high, which means that NPV is highly sensitive to the reduction in the ARPU. As such, the NPV becomes negative if ARPU reduces around 13 % in the deployment scenario of 2.60 GHz, while for 700 MHz the reduction must be around 32 %. Nevertheless, in both cases the network becomes non-profitable. On the other hand, it is clear that NPV is more sensitive to the reduction in ARPU than to the reduction in clients base.

Figure 3.14 shows the NPV variation considering the increase in the price of spectrum. The REF is €3 million for 2.60 GHz and €45 million for 700 MHz. In this result, both lines appear to be nearly horizontal. This means that NPV is not sensitive to the increase in the price of spectrum. It may seem surprising for 700 MHz because, as shown in figure 3.8(b), the price of spectrum represents 5.51 % of the CAPEX for the reference values. However, if we analyze the impact of increasing the price of spectrum in CAPEX, we see that its impact in the worst

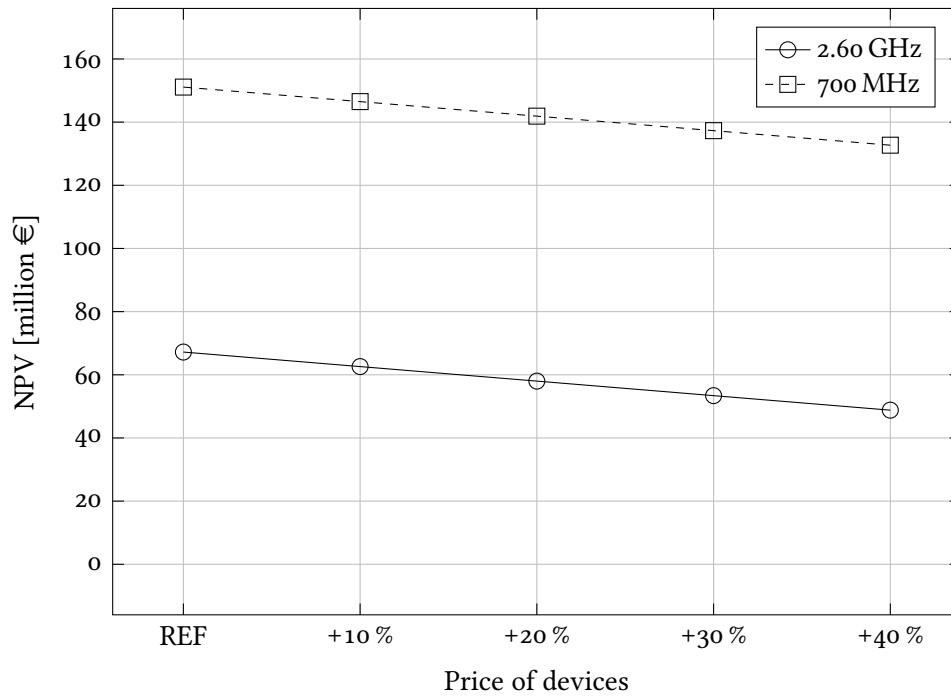

Figure 3.11: Total NPV variation by increasing the price of devices.

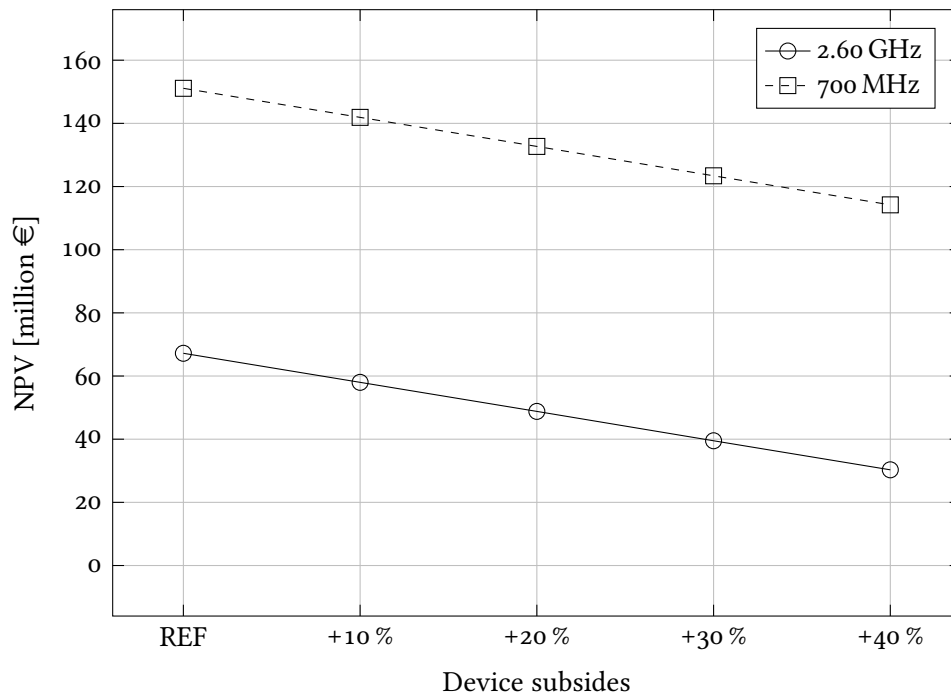

Figure 3.12: Total NPV variation by increasing the device subsidies.

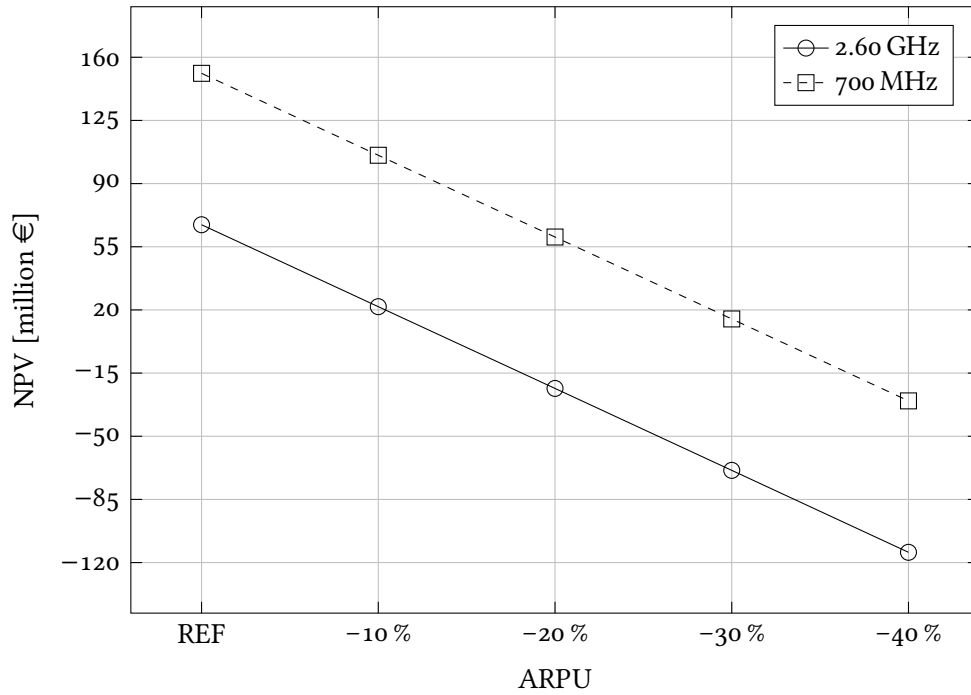

Figure 3.13: Total NPV variation by reducing the ARPU.

case (40% increase) is only around 9% (see figure 3.15); that is a variation of only 3.49%, which demonstrates its lesser impact, being in line with the previous result.

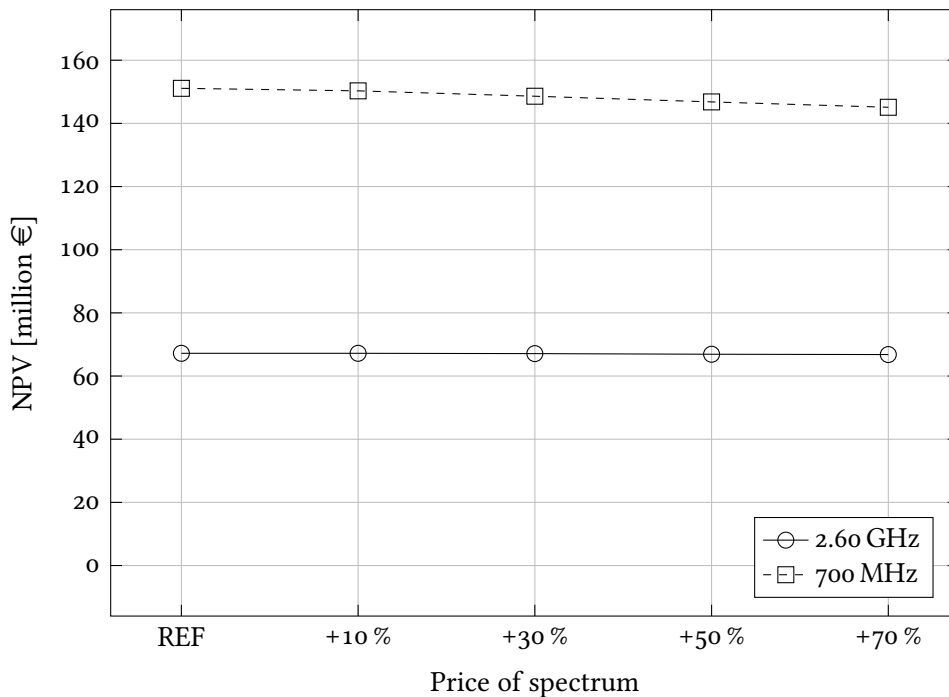

Figure 3.14: Total NPV variation by increasing the price of spectrum.

In figure 3.16 it is presented the variation of NPV considering the increase in the fiber costs. The REF value is €45 000/km. As may be noted, the increase in optical fiber costs affects more the deployment with 2.60 GHz than 700 MHz carrier. In the deployment scenario 1 the radius of cells are smaller due to propagation loss effects. Therefore, to cover the same area, more BSs



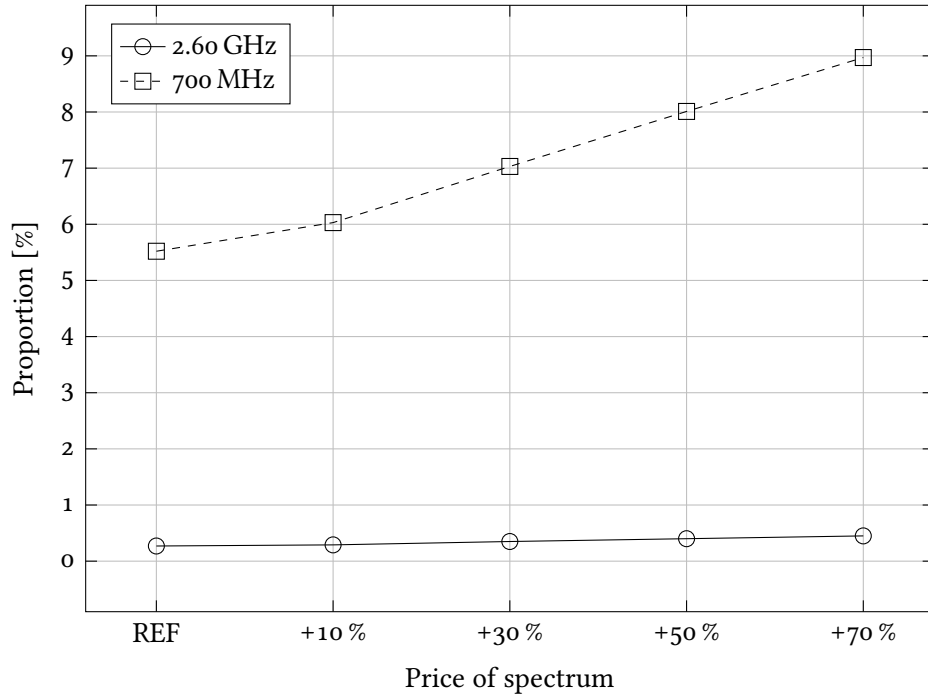

Figure 3.15: Proportion of spectrum costs in the total CAPEX by increasing the price of spectrum.

are required and more fiber is also required to connect those additional BSs, which explains the difference between the slopes of both lines.

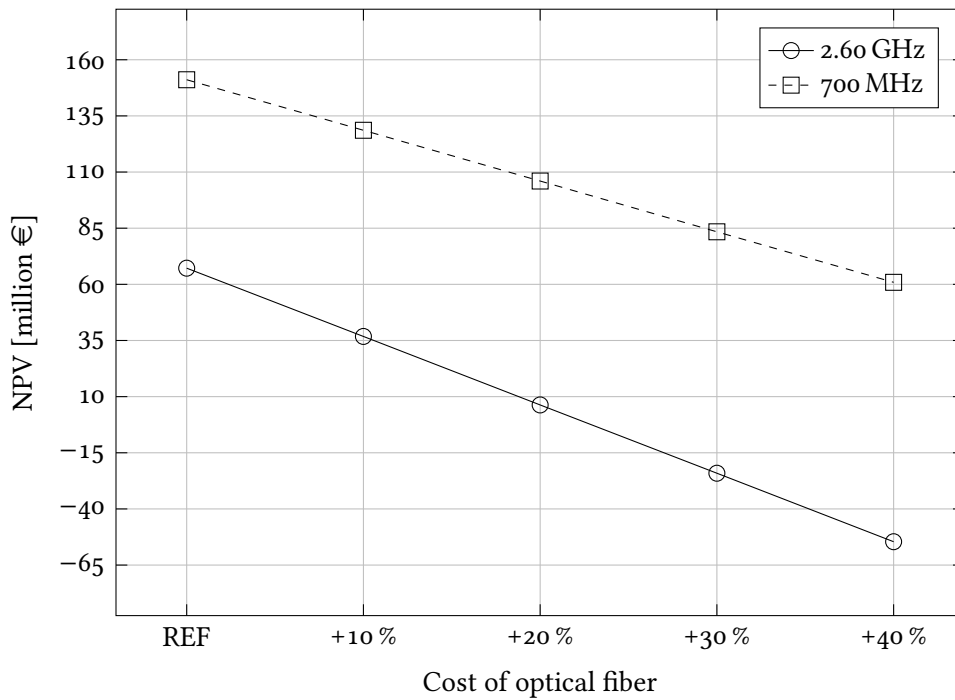

Figure 3.16: Total NPV variation by increasing the cost of optical fiber.

### 3.4.3. NPV, CAPEX, and OPEX for Deployment Scenario 3

With the introduction of a TVWS carrier (700 MHz) in addition to the already planned network using the central carrier frequency of 2.60 GHz, some adjustments were required. These adjustments are expressed in table 3.4. Namely, a cost of 10 % for each BS was added, due to the fact that they need to have at least new antennas for the new carrier, and an additional cost for the TVWS carrier depending on the geographical classification was also introduced.

Moreover, and through system level simulations, it was possible to verify an improvement in the average throughput per user of around 8 % in urban area (1.08 Mbps), and 14 % in sub-urban and rural areas (1.14 Mbps) [105]. In such cases, the operator is comfortable to increase ARPU by 10 % (€14.30) because a better Quality of Service (QoS) will be provided. It is also important to notice that the extra capacity is expected to improve the throughput of best effort services because the network was planned with only a carrier of 2.60 GHz in order to guarantee the estimated traffic in DL of 1 Mbps per user.

Figure 3.17 presents the comparison between the NPV and balance per year of deploying the network when considering only the 2.60 GHz carrier and when the deployment is done using the 2.60 GHz plus an additional TVWS carrier. The deployments use the reference values presented in tables 3.3 and 3.4, respectively.

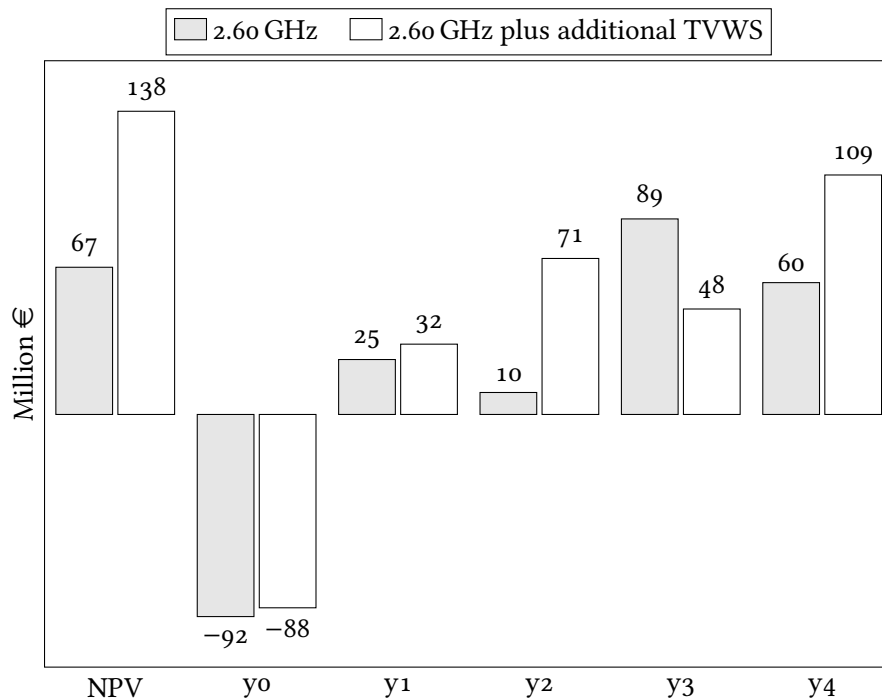

Figure 3.17: Total NPV and balance per year.

In both situations the NPV is positive, which means the project is profitable. Regarding the balance, it is only negative in the first year (y0). In fact, the first year is when most of the investment is done, so it is normal to be negative, and not that much different in both deployment scenarios. However, looking to other years of the study, the balance per year is more positive for 2.60 GHz plus TVWS than when considering a deployment with only 2.60 GHz carrier (the only exception is y3), therefore the total NPV is clearly higher. This result was in fact already expected because, as it was already seen in figure 3.13, the NPV is highly sensitive to the changes in ARPU, thus even with a small increase of 10 % in ARPU for the deployment scenario 3, the effect in NPV is high.

In figure 3.18 the cumulative revenues and costs per year for the deployment scenario 1 are shown; the same result is expressed in figure 3.19 for the deployment scenario 3. If we look only at figure 3.18(a) and figure 3.19(a) we can be tempted to say that the difference between the two deployments considering both the revenues and costs is not significant. However, let us look to the third year ( $y_2$ ). Only in the case of a deployment for 2.60 GHz plus an additional TVWS the revenues bar is slightly above the costs bar for that year; while in the case of a deployment with 2.60 GHz only, the revenues bar is only clearly above costs bar in the fourth year ( $y_3$ ).

A better visual illustration of the same result is depicted in figure 3.19(b), where the line of revenues crosses the line of costs before the third year of deployment, while in figure 3.18(b) it only happens almost at the end of the third year. In other words, it is clear that an operator would recover its investment around one year earlier if it chooses to deploy the network following a flexible spectrum market approach.

Despite the previous results, it is a good idea to determine the main sources of costs in the network. In figure 3.20 the principal contributors to CAPEX and OPEX for the deployment scenario 3 can be seen. Regarding the CAPEX, it is very similar to figure 3.8(a) that was done for a network with only the 2.60 GHz carrier. Actually, this result was expected, because the only added cost to CAPEX is the increase of 10 % in the cost of each BS due to the required additional antenna to support TVWS. The main difference may be seen in OPEX where the annual price of spectrum for TVWS now represents around 12 % of the total OPEX. Nevertheless, device subsidies and replacement costs still remain as the most important contributor to OPEX.

Although, despite the big impact in OPEX, the price of TVWS does not have a visible impact in the total NPV (which remains very positive). This may be explained because with the reference values, 81 % of the costs are CAPEX while only 19 % are OPEX.

#### 3.4.4. Sensitivity Analysis for Deployment Scenario 3

In addition to the sensitivity analysis already done in section 3.4.2, within this section we provide two more sensitivity analysis, namely to assess the influence in the total NPV of increasing the price of a TVWS carrier and the number of hours/day (in average) that the operator must pay to use such carrier (or TVWS channel).

In figure 3.21 it is presented the variation of NPV while the price of TVWS increases. The REF values are: €411/day for urban, €247/day for sub-urban, and €164/day for rural areas. In both cases, for the average use of four hours/day or eight hours/day, the slope of the lines is not very steep; that is the NPV is not very sensitive to the increase in the price of TVWS.

Figure 3.22 shows the variation in NPV while increasing the number of hours/day that an operator must pay for the use of a TVWS carrier. The REF value is four hours/day, which represents in average the typical use time per day of the year.

As it can be seen, once again, the variation of NPV is not very high (around €132 million for REF to around €113 million for 12 hours/day). Since the use of TVWS is to overcome situations of lack in capacity during busy hours, it does not make sense to use the TVWS during the whole day. However, even for the worst case, that is when the operator must pay 24 hours/day for the use of a TVWS carrier, the value of NPV is €84 million, which is clearly above the €64 million obtained when considering only a carrier of 2.60 GHz.

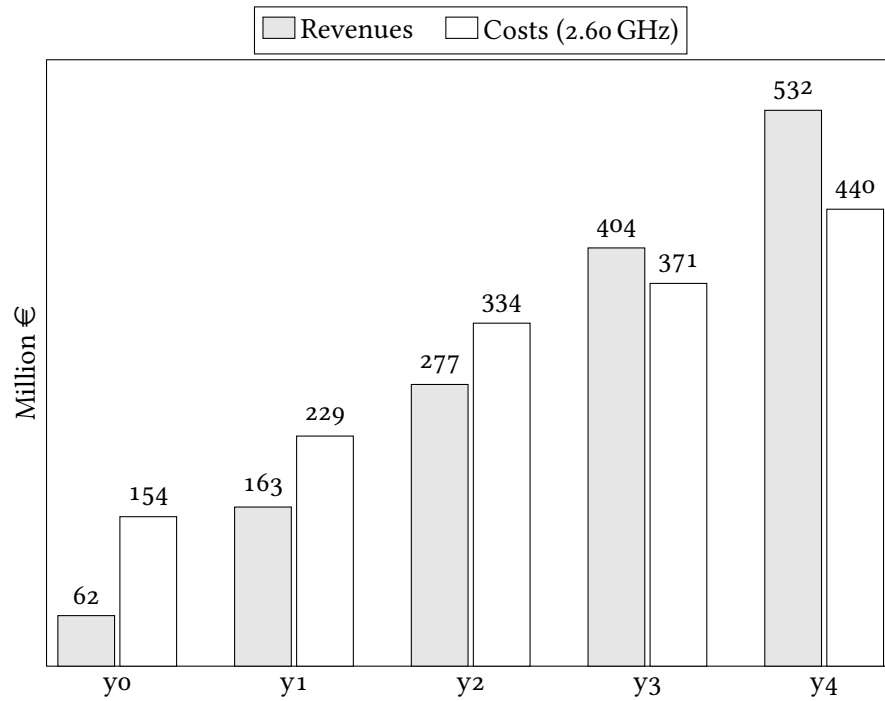

(a) Bar chart.

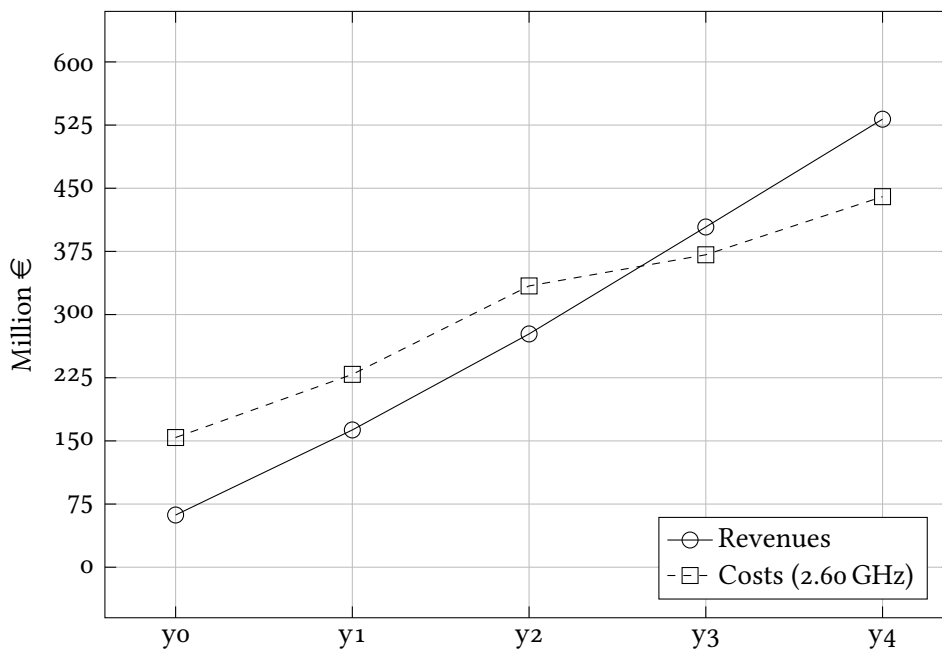

(b) Transition points.

Figure 3.18: Cumulative total revenues and costs per year for deployment scenario 1.

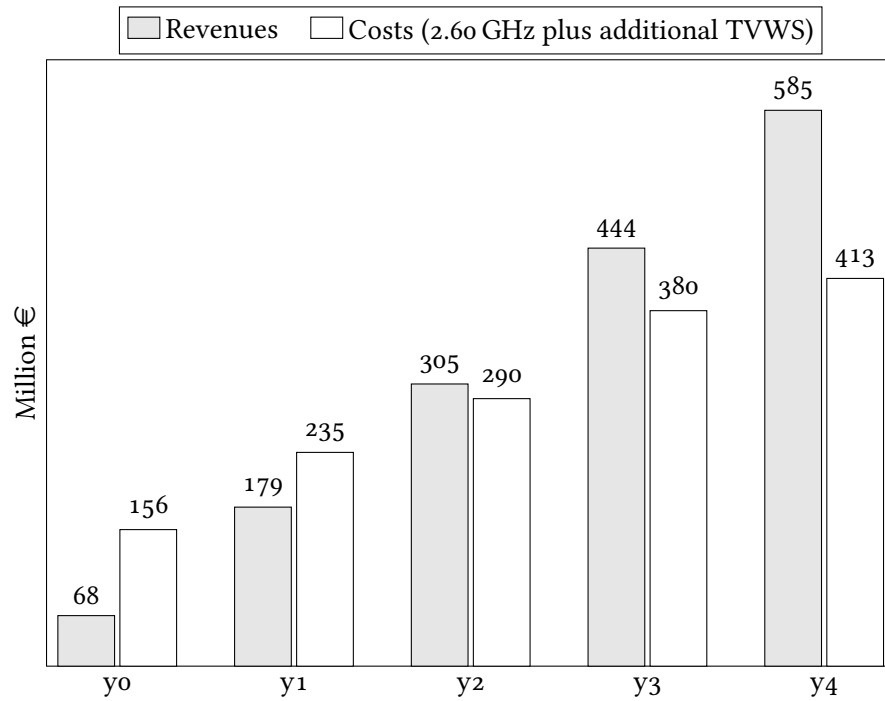

(a) Bar chart.

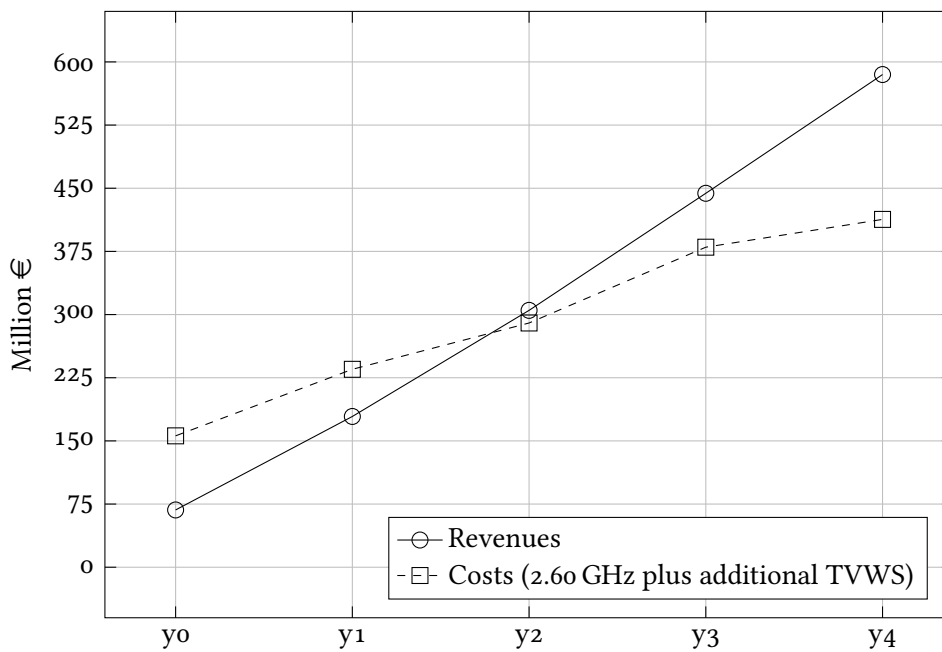

(b) Transition points.

Figure 3.19: Cumulative total revenues and costs per year for deployment scenario 3.

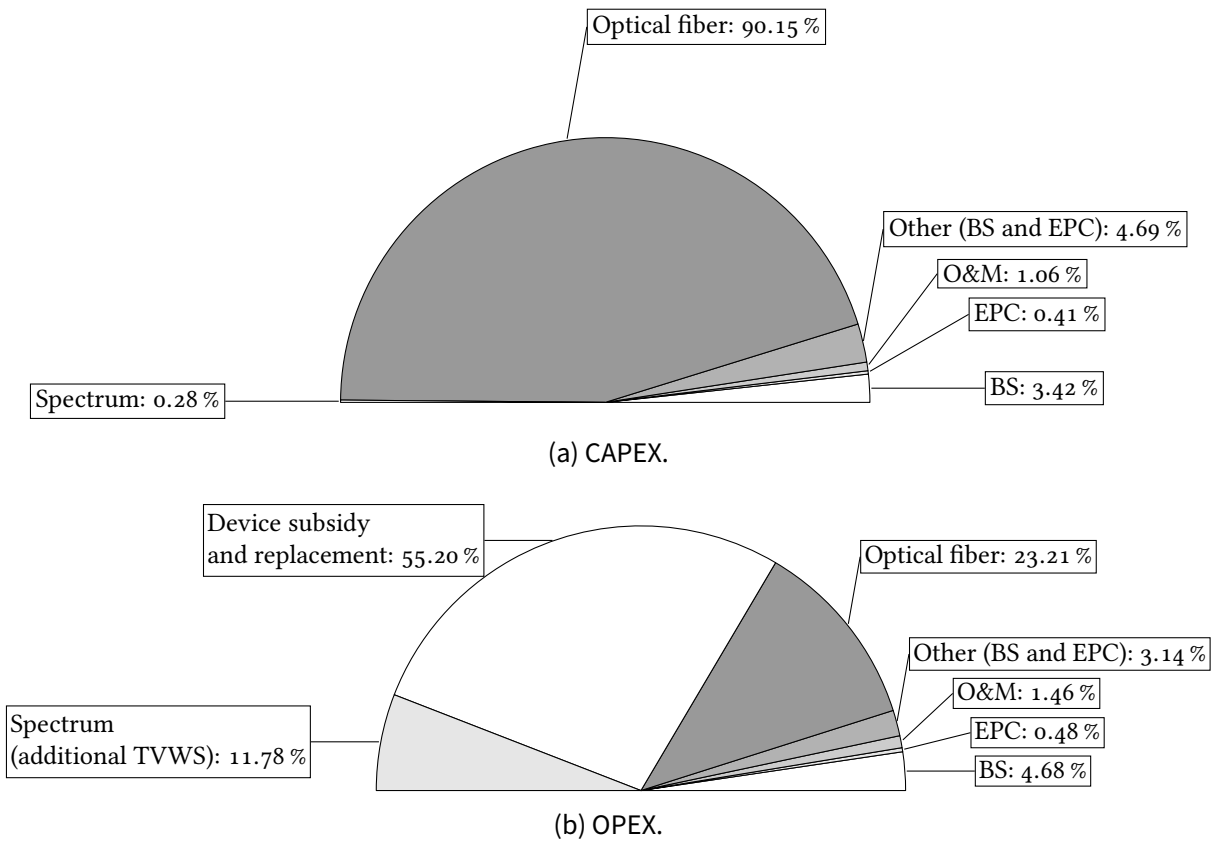

Figure 3.20: Contribution for the total costs of each parameter.

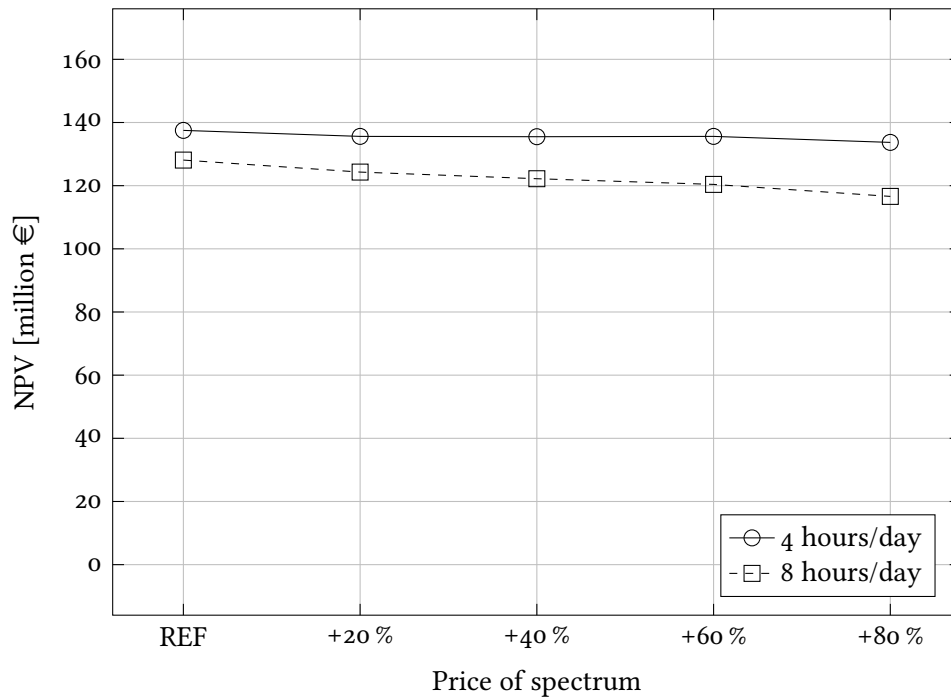

Figure 3.21: Total NPV variation by increasing the price of spectrum (additional TVWS).

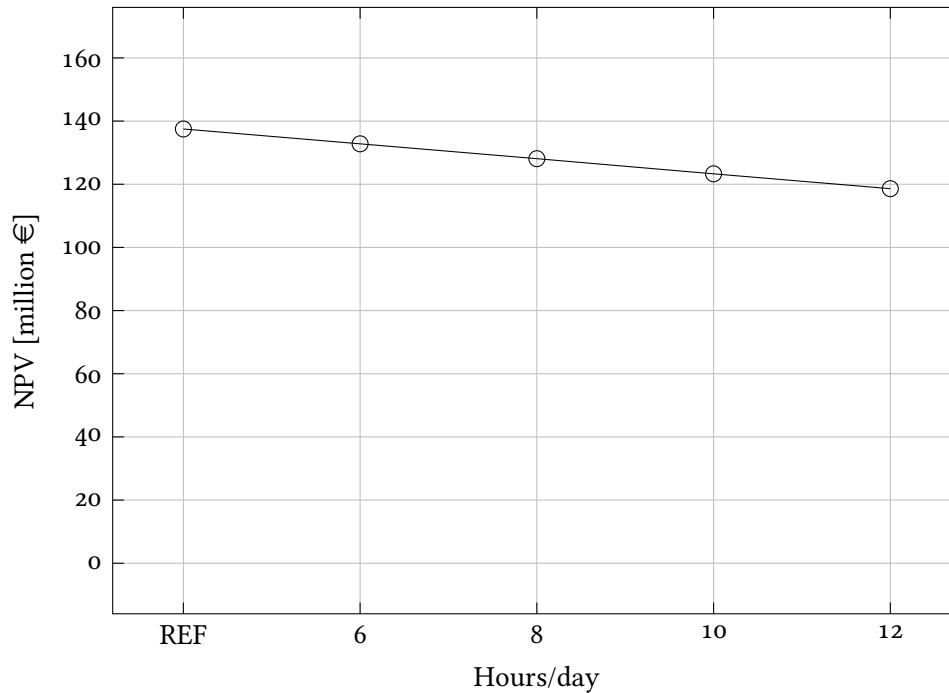

Figure 3.22: Total NPV variation by increasing the number of paid TVWS hours.

### 3.5. Conclusion

The techno-economic evaluation is a way of investigating the profitability of a project and, if correctly done, can help decision makers to take structured strategies (in addition to Strengths, Weaknesses, Opportunities, and Threats (SWOT) analysis presented in chapter 2). However, it is almost impossible to assess all the components and their contribution, even more when the study is for some time in future, because of the time-dependency of many variables (e.g., value of things, interest rate, or inflation tax). It may be even worse for something that is completely new, because there is no past knowledge that can help to predict the future. Therefore, some assumptions for values and their variation through the time must be done.

The NPV metric is commonly used to assess the profitability of a project: a positive NPV states that the project adds value to the company and shall be sustained; while for a negative NPV the project takes value from the company and, accordingly, shall be abandoned; if NPV equals zero, other metrics (or subjective factors) shall be used instead.

The study described in this chapter is for the region of Munich and considering three different LTE network deployments: a deployment with only one carrier, either 2.60 GHz (scenario 1) or 700 MHz (scenario 2), for the traditional spectrum market; and a deployment with the legacy carrier of 2.60 GHz plus an additional TVWS carrier (scenario 3), which is aligned with a flexible spectrum market approach.

Using the reference values of tables 3.3 and 3.4, it was shown that the network is clearly more profitable in the second deployment scenario, where the NPV reaches €151 million, while in the third deployment scenario it reaches €138 million, and for the first deployment scenario the NPV is only €67 million. Therefore, it is evident that an operator would recover its investment in one and half years earlier if it chooses to deploy the network in 700 MHz rather than in 2.60 GHz, and around one year earlier if it chooses to deploy the network following a flexible spectrum market approach with an additional TVWS carrier.

Nevertheless, absolute values of NPV shall be taken with caution due to the assumptions that are done. Therefore, a sensitivity analysis is highly beneficial because it gives a broader view about the factors that influence the NPV and, as a result, the profitability of the project. It is also very useful to establish strategies, e.g., invest in a certain factor that has less influence in the NPV but beneficially interferes with other that highly affects the NPV.

Table 3.5 presents a summary of the sensitiveness of NPV to the variation of each input parameter in the three deployment scenarios (a visual illustration of the same result is presented in figure 3.23). As can be seen, the ARPU is the most important contributor to the total NPV, followed by the cost of fiber, and clients base. The NPV is less sensitive to the variations in the price of devices, cost of spectrum (traditional market or additional TVWS carrier), and the use time of TVWS.

Table 3.5: Summary of the sensitivity analysis regarding the variation of parameters.

Parameter	Sensitiveness of NPV	
	Scenarios 1 and 3	Scenario 2
Clients base	Moderate	Moderate
Price of devices	Small	Small
Device subsidies	Small	Small
ARPU	Very high	Very high
Price of spectrum (traditional market)	Very small	Very small
Price of optical fiber	High	Moderate
Price of spectrum (additional TVWS per 4 hours/day) <sup>†</sup>	Very small	
Price of spectrum (additional TVWS per 8 hours/day) <sup>†</sup>	Very small	
Use time of TVWS <sup>†</sup>	Very small	

<sup>†</sup> Only for the deployment scenario 3.

With the combination of sensitivity analysis and NPV for the deployments with a legacy carrier of 2.60 GHz or when to the legacy frequency is added an additional TVWS carrier, it becomes clear that with the introduction of TVWS, following a flexible spectrum market approach, the level of profitability increases and does not vary much, or in other words, is not too sensitive to changes in the price or use time of TVWS. In such case, the operator may feel comfortable to slightly increase the ARPU, which highly influences the NPV, because with TVWS the network capacity increases and with that a better quality QoS may be provided.

As another example, it was said in the SWOT analysis (chapter 2) that one of the threats is the expected high price of White Space Devices (WSDs). An incentive to the clients is to increase the device subsidies or decrease the device prices with, e.g., some promotions in order to attract new clients and, therefore, increase the clients base. The impact of the clients base on the NPV is moderate, while the effect of the device subsidies and price of devices is small.

Also, a more mathematical approach with the use of partial derivatives would be highly beneficial, since one could identify clearly the contribution of each parameter to the final NPV. However, there is no close form to calculate NPV, which means that such approach is impractical.

Finally, future works may involve:

- The deployment of optimization strategies to reduce the network costs while keeping the same coverage and capacity, and evaluate the use of TVWS in that context;



- Also the use of NPV with Monte Carlo runs [103], [120] to simulate uncertainties with a statistical characteristic (i.e., statistical distribution), is useful to model the risks associated with the flexible spectrum market and perform the sensitivity analysis.

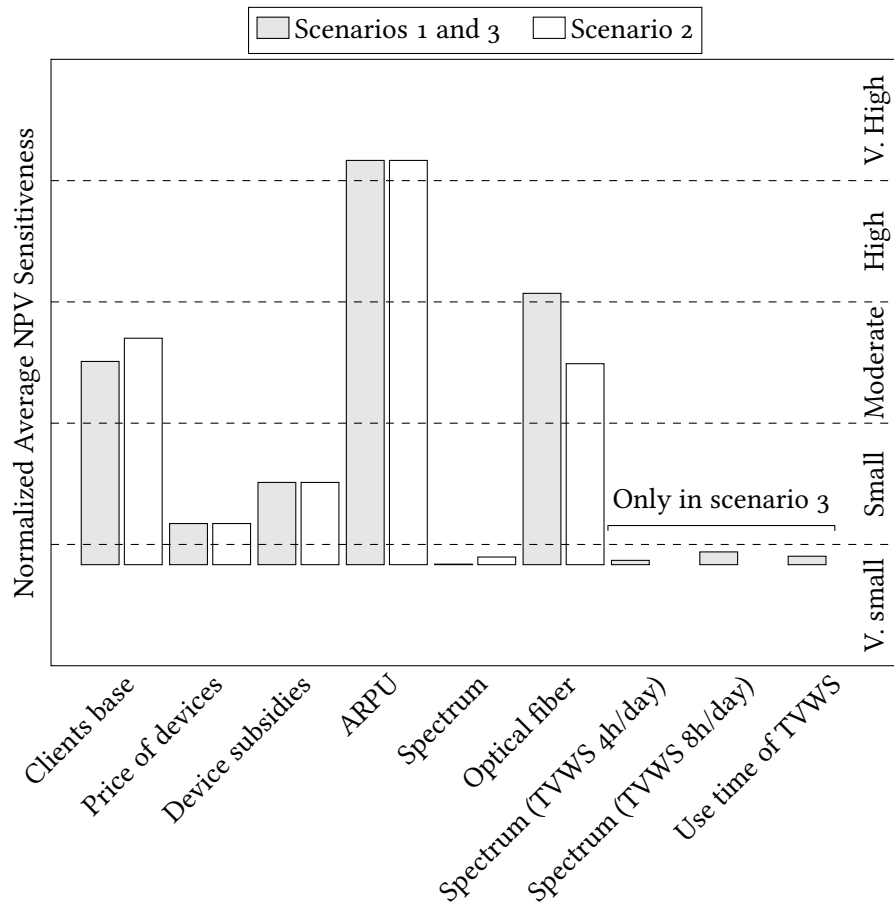

Figure 3.23: Normalized average NPV sensitiveness, which is the slope of the total NPV line while varying each parameter, divided by the highest achieved slope of the total NPV line among all parameters.

## PART II

---

### D2D Communications

---

**T**his part is devoted to the research topic of Device-to-Device (D2D). The part comprises the following chapters:

- Chapter 4. Neighbor Discovery Using Power Vectors for D2D Communications: in this chapter it is proposed a network-assisted technique to discover D2D-capable neighbors of a first Mobile Station (MS) based on the power measurements already available in the network. Results show that with the network help, the time to detect all neighbors per MS is significantly reduced, leaving more time available for data transmission;
- Chapter 5. Band Selection for D2D Communications: in this chapter a novel co-channel interference mitigation algorithm is investigated. The algorithm selects the Downlink (DL) or Uplink (UL) band to be reused by the D2D communication using a radio distance metric. Results proved that interference is mitigated in both communication directions, allowing the coexistence of both cellular and D2D modes, which extends the common recommendation of just reusing the UL band for the D2D links.

## CHAPTER 4

---

# Neighbor Discovery Using Power Vectors for D2D Communications

---

The new Device-to-Device (D2D) communication is seen as a promising technology to increase the capacity of current wireless systems without extra electromagnetic spectrum bands. However, before starting a D2D communication, Mobile Stations (MSs) must be aware of their neighbors, through a discovery process. While operating in cellular networks, such process may benefit from the network assistance. In this chapter, we propose a method based on the available network power measurements to improve the discovery process. Results demonstrate that our proposal is less complex but still outperforms traditional methods when considering the time to detect all neighbors.

### 4.1. Introduction

The notable popularity of smartphones and tablets along with the increasing demand for rich multimedia services and the scarcity of electromagnetic spectrum has motivated the research of technologies that are able to improve the capacity of wireless systems without requiring extra spectrum bands. In this context, D2D communication represents a promising technology that has attracted the attention of scientific community in the last couple of years [26].

As discussed in chapter 1, D2D communication is a new type of direct wireless communication between two or more network radio nodes, hereafter generally referred as MSs<sup>1</sup>, that exploits the proximity between them to achieve very high data rates and low delays, with a reduced power consumption. But, it comes with the cost of introducing additional interference, which is seen as the main drawback. Benefits and challenges of D2D communications, especially in cellular networks, are discussed in, e.g., [26], [27], [121].

However, before commencing a D2D communication, each D2D-capable MS<sup>2</sup> must have the knowledge of its neighbors, i.e., other D2D-capable MSs in the vicinity of the former with which it may directly communicate with. Ideally, MSs shall discover their neighbors as quickly as possible, which enables them to save power. Also, a speedy discovery allows routing and other protocols to quickly start their execution, without significantly decrease the MSs' operation time [122], [123]. Moreover, the discovery shall be adaptive from sparse environments, with just a few MSs, to densely populated places, with large number of MSs [124].

---

<sup>1</sup> The method presented in this chapter can be applied to *any* wireless network and not strictly to Long Term Evolution (LTE) systems, thus we adopted a more general terminology, as Mobile Station (MS) and Base Station (BS). Nevertheless, MS refers to User Equipment (UE) while Base Station (BS) refers to Evolved Node B (eNB) in LTE family standards.

<sup>2</sup> A MS that can operate in cellular or D2D mode (one at time), but preferably uses D2D mode.

Therefore, the main problem herein is to determine the pool of neighbors for each D2D-capable MS: if the process does not occur or no neighbors are found, the D2D communication will not happen; simply because the MS is not aware of other surrounding D2D-capable MSs.

#### 4.1.1. Neighbor Discovery

Neighbor discovery, as described in [123], is the determination of all MS in the network with which a given MS may directly communicate with, i.e., establish a D2D communication.

Immediately after the ad hoc network deployment, a MS has no knowledge about the other MS in its transmission range and needs to discover its neighbors. Therefore, the neighbor discovery process is one of the first steps in the configuration of large wireless networks [125]. The problem becomes crucial in self-organizing networks without preexisting infrastructure. Nevertheless, the number of neighbors is typically orders of magnitude smaller than the size of all network interface addresses, so neighbor discovery is by nature compressed sensing (or sparse discovery) [126]. In addition, neighbor discovery may also be the solution for partner selection in cooperative wireless networks.

The neighbor discovery shall not significantly decrease the operation time of MSs and be scalable to very sparse environments, with few nodes, to crowded places. In a crowded place, the discovery process becomes challenging as well as keeping the energy consumption low. In sparse environments it may happen that there are no neighbors and the scanning process must not completely drain the MS's battery [124]. Furthermore, energy efficiency in maintaining the network and guaranteeing a low duty cycle [127] are also desirable.

The final step in the D2D link establishment procedure is to trigger a beacon between the D2D server and client to evaluate the actual quality of the channel and build the required routing tables. In LTE-like networks, the D2D link quality is reported to the eNB and serves as the basic input to mode selection, i.e., select cellular or D2D communication modes [35].

#### Disambiguation

One may confuse the neighbor discovery (sometimes also referred in literature as peer discovery) in the context of D2D communications with BitTorrent services<sup>3</sup> and their peer discovery mechanism. First, there is a clear difference in the concept, studied problems, and proposed solutions; second, the D2D communication focus the physical and link layers, namely Medium Access Control (MAC) sublayer; while BitTorrent is a service and, therefore, considered in upper layers (network, transport, and application).

Moreover, D2D communications are being proposed for ad hoc wireless networks, and also for the cellular domain as an underlay (secondary) network of the primary one [27]. Hence, the radio nodes participating in D2D communications form a network that is capable of exchanging data: transfer files, voice conversation, audio and video streaming, or other kind of services.

The D2D-related mechanisms are somehow similar to the ones that do exist in Bluetooth technology<sup>4</sup>—peer discovery and device pairing—where the so-called *inquiry process* allows a potential master MS to identify other MSs in range that wish to participate in a piconet,

---

<sup>3</sup> BitTorrent is a Peer to Peer (P2P) file sharing protocol used for distributing large amounts of data over the Internet [128].

<sup>4</sup> See <http://bluetooth.org>.

whereas the *paging process* allows the master MS to establish links towards the desired slave MS [26].

### Algorithms Classification

According to [125] the neighbor discovery algorithms can be classified in two main categories: randomized or deterministic. However, many other divisions may also apply, depending on the type of, e.g., technology, network organization, focused layers, antennas, protocols, or signaling methods. A good discussion on neighbor discovery algorithms (namely for ad hoc networks) and their classification can be found in [129], [130].

Considering the type of network and the knowledge of its structure, the neighbor discovery algorithms may be used in deterministic or random networks. In a deterministic network, the structure is mostly static and well-known, therefore reorganizations are infrequent. On the other hand, for random networks, the neighbor discovery algorithms must cope with uncertainty and common reorganizations due to, e.g., entrance/exit of MSs and their movement, and thus parameters may drastically change between sessions [27], [122], [131]. For random networks, the list of neighbors and routing tables shall at least be updated before the establishment of each data link, while for deterministic networks, the bootstrap configuration (this is, when MSs are turned on) may be sufficient to keep lists updated.

Neighbor discovery protocols are sometimes generally classified as one-way neighbor discovery or handshake-based neighbor discovery [132]; they can also be classified as power detection or protocol-oriented, respectively. Power detection neighbor discovery requires that each MS periodically sends out advertising packets (in random or defined directions) to announce its presence, and neighbors are discovered by receiving their advertising packets [124]. For protocol-oriented neighbor discovery, a MS needs to provide active response to the sender after receiving an advertising packet from an unknown neighbor. Protocol-oriented neighbor discovery is usually implemented at MAC sublayer, while power detection neighbor discovery is in physical layer. Relying only on power detection, i.e., carrier sensing at physical layer, may lead to undetected neighbors and the *hidden node problem*.

Actually, the *hidden node problem* is one of the main sources of packet collision in wireless networks: when two or more MSs attempt to transmit a packet across the network at the same time, a packet collision occurs. Although, if a collision happens and no recover is possible, the detection of neighbors can be compromised. Collisions may be avoided by the use of wide-spaced channels, carrier sensing mechanism (which are implemented at MAC sublayer), or at modulation level, like using Orthogonal Frequency Division Multiplexing (OFDM)-based schemes [130], [133]. Moreover, synchronous (or slotted) detection may also be implemented to mitigate collisions and, therefore, all MSs transmit following a common reference frame, which is allowed with the distribution of a local clock [129]. In asynchronous detection, there is no cooperation between MS. Hence, their transmission slots are misaligned which conduct to detections up two times slower than in the synchronous counterpart [125], [134].

Other common division to evaluate the probability and required time to detect all neighbors is the distinction between randomized and deterministic neighbor discovery [125]. In randomized neighbor discovery, each MS transmits at randomly chosen times and neighbors are detected with high probability within a predefined timeout. In a deterministic neighbor discovery, each MS transmits according to a predetermined schedule which allows the detection of all neighbors during the timeout. In deterministic neighbor discovery, the transmission may occur, e.g., like in the well-known *token ring protocol* that exists for wired networks; where

token-possession grants the possessor permission to transmit on the medium, i.e., when a MS transmits, the other MSs listen, thus avoiding collision problems. In randomized neighbor discovery, collisions are likely to occur. In [125], [127] the detection of neighbors is reduced to *coupon collector's problem*, where the time to detect all neighbors is lower and upper bounded with closed form expressions.

Regarding the type and number of antennas, two division can be considered: the use of omnidirectional or directional antennas, and Single Input Single Output (SISO) or Multiple Input, Multiple Output (MIMO) schemes. Many neighbor discover protocols have been proposed that use directional antennas. Directional antennas concentrate their beams according to specific directions, which enables selectivity in the reception (along with the increase of Signal to Interference-plus-Noise Ratio (SINR)) and for a given transmission power, the communication range is greatly extended [122]. However, the *hidden node problem* [135] and *deafness* [136] due to misalignment in transmitter and receiver's antennas are common problems. As such, protocol design using directional antennas is a challenging problem, while neighbor discovery is seen as relatively simpler problem when omnidirectional antennas are used because a simple broadcast can reach all MSs within the transmission range [131].

For the spatial diversity, conventional MIMO schemes require that both the transmitter and receiver must be equipped with multiple antenna arrays. In practice, however, many MSs may not be able to support multiple antennas due to size, cost, and/or hardware limitations. For D2D communications an alternative approach is to use cooperative MIMO: that is to group multiple MS into virtual antenna arrays to emulate MIMO communications [137]. For example, when a target MS temporarily suffers from bad channel conditions or requires relatively high rate service, its neighboring MSs can help to provide multi-hop coverage or increase the data rate by relaying information to the target MS, or even detect MSs that were inaccessible in other way. Typical neighbor discovery algorithms use SISO, thus they can only provide one-hop information.

Finally, neighbor discovery algorithms can also be divided according to the type of network for which they were projected. In the self-sufficient (or unsupervised) neighbor discovery algorithms, the MSs rely only on themselves to detect neighbors. There is no central coordinator MS neither a central database of yet discovered MSs. Typically, self-sufficient algorithms are implemented in wireless ad hoc networks. On the other hand, the network-assisted (or supervised) neighbor discovery is likely to be implemented in typical cellular networks, where the access network (and core network) cooperates with MSs to detect D2D candidates [27]. In network-assisted neighbor discovery, the identification of D2D candidates can be done using *a-priori* or *a-posteriori* schemes [26]. The *a-priori* scheme is used if MS or network detects D2D candidates just before commencing the communication data session between MSs in cellular mode; while *a-posteriori* scheme is employed if D2D candidates are only detected during the ongoing cellular communication sessions.

#### 4.1.2. Decentralized vs. Network-Assisted Discovery

As such, each MS may employ a neighbor discovery mechanism without being network-assisted. This is a decentralized beaconing mechanism [138], [139], where each MS acts only on its own. The natural improvement is to combine the beaconing mechanism with an exchanging protocol, where the Identitys (IDs) of already detected neighbors are shared between all MSs in the neighborhood [131]. However, both approaches have the following problems:

- Time to discover and stopping criteria: if the discovery process takes too long, it may be useless, since no time is left for data transmission, and good stopping criteria are difficult to be effectively defined [125]. This is especially relevant because the surrounding environment is unknown and the discovery may happen from sparse to crowded environments [124], [126];
- Power consumption: the discovery process may completely discharge the MS's battery, namely if the number of possible neighbors is not prior-known and stopping criteria are not correctly implemented [124], [140];
- New protocol: for the beaconing sequence, and particularly in the case of exchanging information about the already known (discovered) neighbors, a new protocol needs to be defined and implemented [141], implying more network load on signaling;
- *Hidden MS problem*: relying only on power detection at physical layer, and, for directional antennas, the misalignment between transmitter and receiver's antennas, may lead to undetected neighbors [135];
- Fake MS attack: security attacks may happen from a MS which fakes its ID and pretends to be another.

In order to overcome the problems mentioned above, MSs may be network-assisted [26], [124], [140], [142] to determine the pool of their neighbors, speeding up the discovery process along with its accuracy. Therefore the proposed neighbor discovery method of this thesis, which is described in section 4.2, is an *a-priori* network-assisted method based on power detection.

The rest of the chapter is organized as follows: in section 4.2 a detailed explanation about power vectors and the neighborhood matrix is given, in section 4.3 the system model used in simulations is presented, in section 4.4 the main results are shown and discussed, in section 4.5 the single-cell scenario described in section 4.2 is generalized for the multi-cell case, and in section 4.6 the chapter conclusions are drawn.

## 4.2. Power Vectors and Neighborhood Matrix

In this section we focus on the detailed explanation about power vectors and how to construct the neighborhood matrix. For this, the explanation below is based on figure 4.1 that presents a set of messages exchanged between the serving BS and D2D-capable MSs.

### 4.2.1. Collecting Power Measurements from Neighbor Cell List

All MSs while operating in structured networks, as the case of cellular systems, need to perform a set of measurements. One of the very basic of those measurements is the received power from their serving BS. Furthermore, MSs must also perform power measurements on the pilots of vicinity cells (phase 1 of figure 4.1) and report back those values to the serving BS (phase 2 of figure 4.1). This procedure is mandatory in any cellular system because of mobility and cell-reselection, due to, e.g., handover and resource allocation reasons. Additionally, a timestamp can be associated to each set of power measurements and if a power measure is detected to be too old (outside a given useful lifetime period), it can be discarded and a new measurement requested.

Moreover, each BS knows its neighbor cells which are stored in a list, commonly described as Neighbor Cell List (NCL) or monitored set. Note that the model is easily extensible to other

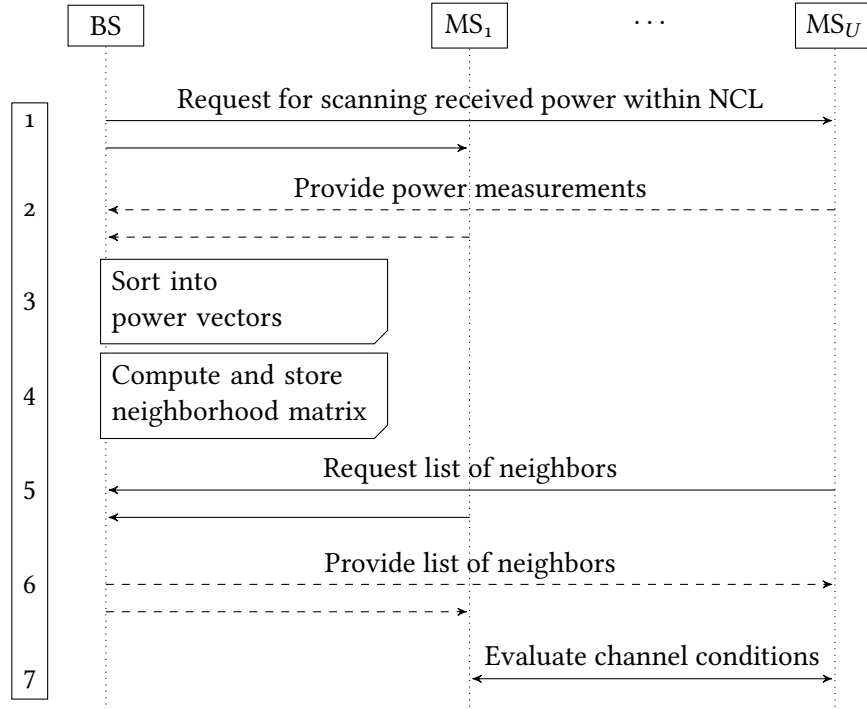

Figure 4.1: Messages exchange between the serving BS and D2D-capable MSs.

systems, such as Wireless Local Area Network (WLAN) and Worldwide Interoperability for Microwave Access (WiMAX), since most systems already dispose of methods to measure the received power, which is used, at least, during connection establishment [26], [143].

#### 4.2.2. Sorting Power Measurements into Power Vectors

The reported power measurements are then sorted in what is called power vectors (phase 3 of figure 4.1), i.e., each MS has reported different power values for the scanned BSs and since both MS and cell's IDs are assumed to be unique, it is easy for the serving BS to arrange them in a specific order, like in equation (4.1), with  $\mathbf{P} \in \mathbb{R}^{U \times B}$ , where  $U$  is the number of MSs within the BS serving area and  $B$  the number of BSs to be scanned, i.e., number of elements within the NCL, see figure 4.2,

$$\mathbf{P} = \begin{bmatrix} \mathbf{p}_1 \\ \mathbf{p}_2 \\ \vdots \\ \mathbf{p}_U \end{bmatrix} = \begin{bmatrix} p_{1,1} & p_{1,2} & \cdots & p_{1,B} \\ p_{2,1} & p_{2,2} & \cdots & p_{2,B} \\ \vdots & \vdots & \ddots & \vdots \\ p_{U,1} & p_{U,2} & \cdots & p_{U,B} \end{bmatrix}. \quad (4.1)$$

In this representation, each row is a power vector  $\mathbf{p} \in \{\mathbf{p}_1, \mathbf{p}_2, \dots, \mathbf{p}_U\}$ , where  $p_{u,b}$  is the power received by  $MS_u$  from  $BS_b$ , with  $u \in \{1, 2, \dots, U\}$  and  $b \in \{1, 2, \dots, B\}$ .

Considering the case of LTE family standards the power measurements would be the Reference Signal Received Power (RSRP) and Reference Signal Received Quality (RSRQ), and the ID of each MS can be obtained with the Demodulation Reference Signal (DMRS) which is sent in Uplink (UL), and the cell ID with the Physical-layer Cell ID (PCI) transmitted in Downlink (DL) [108], [144].

Whenever the received power for a specific BS cannot be measured due to any particular reason, a standard value (e.g., zero or maximum long-term fading value towards the first ring



of interfering cells) may be used to fill the corresponding gap in the power vector so that the method is still applicable. Additionally, this value can be controlled, limiting the number of false neighbors and maximizing the number of real neighbors.

Also, the received power from the serving BS is orders of magnitude greater than the received power from other BSs. Thus, to not bias/polarize the results, the received power from the serving BS shall be removed from the power vector of each MS (i.e., set to zero).

### 4.2.3. Building the Neighborhood Matrix

When values are organized in the form of power vectors (phase 3 of figure 4.1), a cross correlation metric,  $\rho$ , is used to determine the correlation between them. Therefore, taking two different power vectors and defining a correlation threshold,  $P_{TH}$ , two cases may happen:

- The correlation is high, i.e.,  $\rho > P_{TH}$ . In this case, MSs are considered neighbors because their set of measurements is very similar, so it is likely to happen that they are in physical proximity<sup>5</sup>;
- The correlation is low, i.e.,  $\rho \leq P_{TH}$ . In this case, MSs are not considered as neighbors because their set of measurements is not similar, hence it is likely to happen that they are far away from each other.

Clearly,  $P_{TH}$  may assume values in the range of zero to one. In one hand, and since we seek to find high correlated vectors, correlation values below 0.5 are not relevant, while above 0.5 may indicate that two MSs are potential neighbors. On the other hand, if the correlation threshold is set too close to one, eventually many neighbors will be discarded just because their set of measurements differ in very few elements, while a  $P_{TH}$  too close to 0.5 may translate in more false neighbors (and wasted neighbor detection time). Thus, a reasonable value for the correlation threshold shall be around 0.75.

The next step is to calculate the cross correlation metric among all power vectors. A possible metric is defined in equation (4.2).

$$\rho_{x,y} = \left\langle \frac{\mathbf{x}}{\|\mathbf{x}\|}, \frac{\mathbf{y}}{\|\mathbf{y}\|} \right\rangle, \text{ and } x \neq y \in \{1, 2, \dots, U\}, \quad (4.2)$$

where  $\rho_{x,y}$  is the normalized cross correlation for power vectors  $\mathbf{x} \neq \mathbf{y} \in \{\mathbf{p}_1, \mathbf{p}_2, \dots, \mathbf{p}_U\}$ ; or in other words,  $\mathbf{x}$  and  $\mathbf{y}$  are the contents of two different rows of matrix  $\mathbf{P}$ .  $\langle \cdot, \cdot \rangle$  is the inner product defined as  $\langle \mathbf{i}, \mathbf{j} \rangle = \sum_{k=1}^K i_k j_k$  and  $\|\cdot\|$  is the  $l_2$  norm as  $\|\mathbf{i}\| = \sqrt{\sum_{k=1}^K |i_k|^2}$ , with  $\mathbf{i} = [i_1 \ i_2 \ \dots \ i_K]$  and  $\mathbf{j} = [j_1 \ j_2 \ \dots \ j_K]$ .

Moreover, since  $\mathbf{x}$  and  $\mathbf{y}$  are composed by non-negative quantities,  $\rho_{x,y}$  will range between zero (non-correlated) and one (very high correlated). Finally, the neighborhood matrix, shown in equation (4.3), is constructed and stored in the BS (phase 4 of figure 4.1) as follows:

- If the correlation between  $MS_x$  and  $MS_y$  is high, they are tagged as neighbors, and  $\rho_{x,y}$  fills the corresponding  $(x, y)$  and  $(y, x)$  indexes (note that  $\rho_{x,y} = \rho_{y,x}$ );
- Otherwise,  $MS_x$  and  $MS_y$  are tagged as non-neighbors, and a zero fills the corresponding  $(x, y)$  and  $(y, x)$  indexes.

<sup>5</sup> The real position within the cell is most of the times unavailable. However, cellular links with similar channels do have similar propagation effects related with distance, path blockage, and motion.

$$\Omega = \begin{bmatrix} 0 & w_{1,2} & \dots & w_{1,U} \\ w_{2,1} & 0 & \dots & w_{2,U} \\ \vdots & \vdots & \ddots & \vdots \\ w_{U,1} & w_{U,2} & \dots & 0 \end{bmatrix}, \quad (4.3)$$

with

$$w_{x,y} = \begin{cases} \rho_{x,y}, & \text{if } x \neq y \text{ and } \rho_{x,y} > P_{\text{TH}}, \\ 0, & \text{otherwise.} \end{cases}$$

Note that matrix  $\Omega \in [0, 1]^{U \times U}$  is symmetric, thus only its lower or upper triangles may be used, e.g., for saving storage space. Also, the proposed normalized cross correlation metric expressed as the normalized inner product between two power vectors is one possible correlation metric, but other metrics can be used instead, that are easily found in literature (e.g., see [145, section 9.6] or the Pearson product-moment correlation coefficient). Similarly, instead of using the real correlation value in matrix  $\Omega$ , ones can be stored whenever  $x \neq y$  and  $\rho_{x,y} > P_{\text{TH}}$ , obtaining a binary matrix. Withal, by storing real values, they may be used to sort the list of neighbors of a MS, improving routing protocols in multicast or broadcast scenarios.

#### 4.2.4. Storage and Exchange of Neighborhood Matrix

Next, the corresponding row or the full neighborhood matrix is delivered to MSs upon request (phases 5 and 6 of figure 4.1). Moreover, the D2D link must be evaluated before commencing a D2D communication (phase 7 of figure 4.1) by any means. For example, the D2D link may be evaluated using the beaconing approach with a specific training sequence. In the results, section 4.4, it is done using a Markov chain.

Additionally, regarding the running time for the message flowchart in figure 4.1 it can be settled in the following basis:

- Phases 1 to 4: may be done at every 200 ms to 1 s, or 200 to 1000 Transmission Time Intervals (TTIs) [143];
- Phases 5 to 7: may be done at each new service request or whenever the MS is scheduled.

### 4.3. System Model and Simulation Framework

In this section we describe the models and simulation framework that were adopted to evaluate the system performance. Simulations are divided in two main parts: in the first part, the simulation scenario is built and the neighborhood matrix is computed as described in section 4.2; and in the second part, each D2D-capable MS uses the direct link to perform the detection of its neighbors being network-assisted or not.

#### 4.3.1. Cellular Scenario

Consider a network where each BS is placed at the center of a site, which is represented by a regular hexagon. This scenario corresponds to a regular multi-cell network as presented in figure 4.2. The urban-microcell propagation environment is used, where each site is a single-cell [146]. Therefore, the multi-cell scenario has  $B$  cells and each one serves  $U$  MSs uniformly dropped over its coverage area. Moreover, all MSs and BSs are equipped with a single omnidirectional antenna [147].

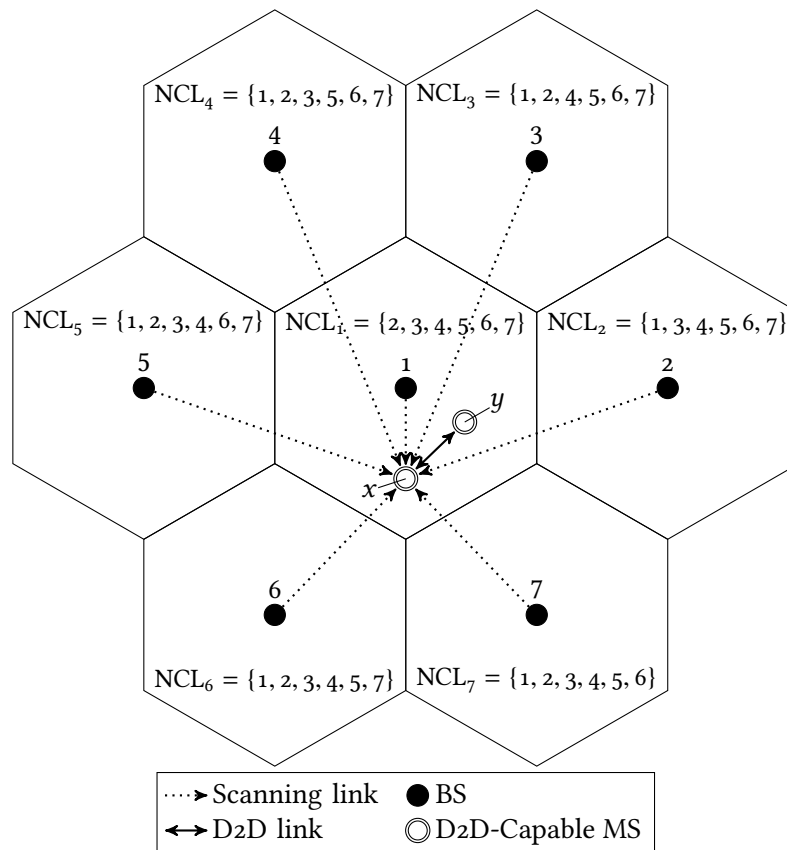

Figure 4.2: Simulation scenario; MS $_x$  and MS $_y$  perform the scanning within  $NCL_1$  (for MS $_y$  it is not shown in the picture), and since  $\rho_{x,y} = \rho_{y,x} > P_{TH}$  they are neighbors and may form a D2D pair.

Despite the multi-cell scenario, each BS acts on its own, i.e., no connection between BSs is assumed. Hence, statistics are independently collected and treated within each cell coverage area. Furthermore, all MSs are D2D-capable, thus the number of possible neighbors per MS is simply given by  $U - 1$ .

The cellular channel modeling includes the long-term fading propagation effects, namely, pathloss and shadowing. Channel variations due to shadowing are modeled with a lognormal distribution of zero mean and standard deviation  $\sigma_{\text{sh}}$ . No fast (or short-term) fading model is used, meaning that during the scanning period (phases 1 and 2 of figure 4.1) MSs are assumed to be stationary<sup>6</sup>. Further aspects of the propagation models are described in [146], [147]. The cellular channel is the one used to build the neighborhood matrix.

#### 4.3.2. Device-to-Device Channel

The wireless channel is a time-variant channel, therefore an option to characterize that channel is to use Markov chains; which are stochastic processes with a limited number of states and whose transition between them is based on the probability of an event. Those states in Markov chains can be defined in agreement to real channel conditions of a scenario, i.e., long- and short-term fading effects [148].

As such, to model the D2D channel we used a simplified stochastic two-state Markov channel like in [149],  $S = \{0, 1\}$ , as presented in figure 4.3, where  $s \in S$  represents the channel link quality state. When the channel link quality is good, the state is  $G$  or  $s = 0$ . For the case of bad channel link quality, the state is  $B$  or  $s = 1$ . The good is meant for the Line of Sight (LOS) condition, while bad reflects the opposite, i.e., Non-Line of Sight (NLOS) condition.

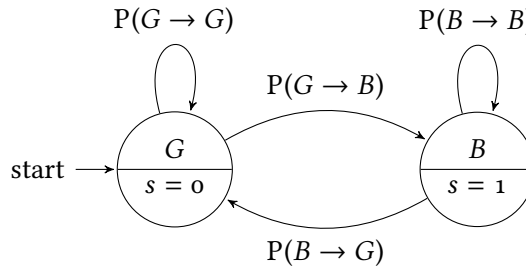

Figure 4.3: Stochastic two-state Markov channel.

The switching between states is established in the probability transition matrix  $\mathbf{M}$ . This is a squared matrix whose order equals the number of states (i.e., cardinality of  $S$ ), and its elements represent the probability,  $P(\cdot)$ , of changing or remaining in the same state.

$$\mathbf{M} = \begin{bmatrix} m_{0,0} & m_{0,1} \\ m_{1,0} & m_{1,1} \end{bmatrix} = \begin{bmatrix} P(G \rightarrow G) & P(G \rightarrow B) \\ P(B \rightarrow G) & P(B \rightarrow B) \end{bmatrix}, \quad (4.4)$$

where  $0 \leq m_{i,j} \leq 1$  and  $\sum_j m_{i,j} = 1$  and  $i, j \in S$ .

The total appearing percentage of a state in Markov chain is given by the steady-state vector  $\boldsymbol{\pi} = [P(G) \ P(B)]$ . This vector can be computed by raising  $\mathbf{M}$  to a large power, i.e.,

$$\lim_{n \rightarrow +\infty} \mathbf{M}^n = \mathbf{1}\boldsymbol{\pi},$$

<sup>6</sup> Usually the power measurements reported to BS by MSs are long-term measurements that are taken as an average within a certain time window, therefore fast fading is filtered out.

implying that in a steady state  $\boldsymbol{\pi} = \boldsymbol{\pi}\mathbf{M}$ , where  $\mathbf{1} = [1 \ 1]^T$  is a column vector of ones. A property of vector  $\boldsymbol{\pi}$  is that the sum of its elements must be equal to the unity,  $\sum_j \pi_j = 1$ , with  $\pi_j$  being the steady-state probability for state  $j$ .

For the case of low probability of LOS conditions and strong multipath because of, e.g., the motion of MSs, buildings and/or trees blockage, we used  $\mathbf{M}$  and  $\boldsymbol{\pi}$  as in equation (4.5),

$$\mathbf{M} = \begin{bmatrix} 0.2 & 0.8 \\ 0.2 & 0.8 \end{bmatrix} \Rightarrow \boldsymbol{\pi} = [0.2 \ 0.8]. \quad (4.5)$$

In our simplified model, we consider that a neighbor is only detected if the channel link quality between two D2D-capable MSs is good, i.e., state  $G$  or  $s = 0$ , because only in that state the SINR is above an established detection threshold.

#### 4.4. Results and Discussion

In this section, the results regarding the time to detect all neighbors per MS, measured in terms of the total number of tries<sup>7</sup>, are presented. Table 4.1 summarizes the parameters used in simulations. Moreover, three methods are compared:

- Power vectors: the proposed method as previously described, where each MS has the full information of its neighbors (i.e., total number of neighbors and their IDs) provided by the serving BS, and for this method no false detections happen;
- Semi-Blind: follows a beaconing approach [138], [139], where each MS knows the number of its neighbors, but their IDs remain unknown;
- Blind: similar to semi-blind method, but each MS only knows the number of its potential neighbors, i.e., the total number of MSs within the cell except itself.

Table 4.1: Simulation parameters.

Parameter	Value	Reference
Number of BSs ( $B$ )	7	
Cellular environment	Urban-microcell	[146]
Inter-Site distance	500 m	[146]
BS transmit power	38 dBm	[147]
Number of MSs per cell ( $U$ )	8, 16, 32, 64, 128	
Number of Monte Carlo runs	300	
Correlation threshold ( $P_{TH}$ )	0.75	
Central carrier frequency	1.90 GHz	[146]
Cellular pathloss model [dB]	$34.5 + 38 \log_{10}(d)$ , $d$ in meter	[146]
Shadowing std. dev. ( $\sigma_{sh}$ )	10 dB	[147]
Antenna configuration	SISO, omnidirectional	
D2D channel links	Two-state Markov channel	[149]
Probability of LOS conditions	Low: $P(B) = 0.8$	

The total number of tries to detect all neighbors considering 64 MSs per cell is presented in figure 4.4. As it can be seen the proposed method clearly outperforms the other two methods.

<sup>7</sup> A try is defined as an attempt to detect a neighbor; a successful try means that a neighbor was detected.

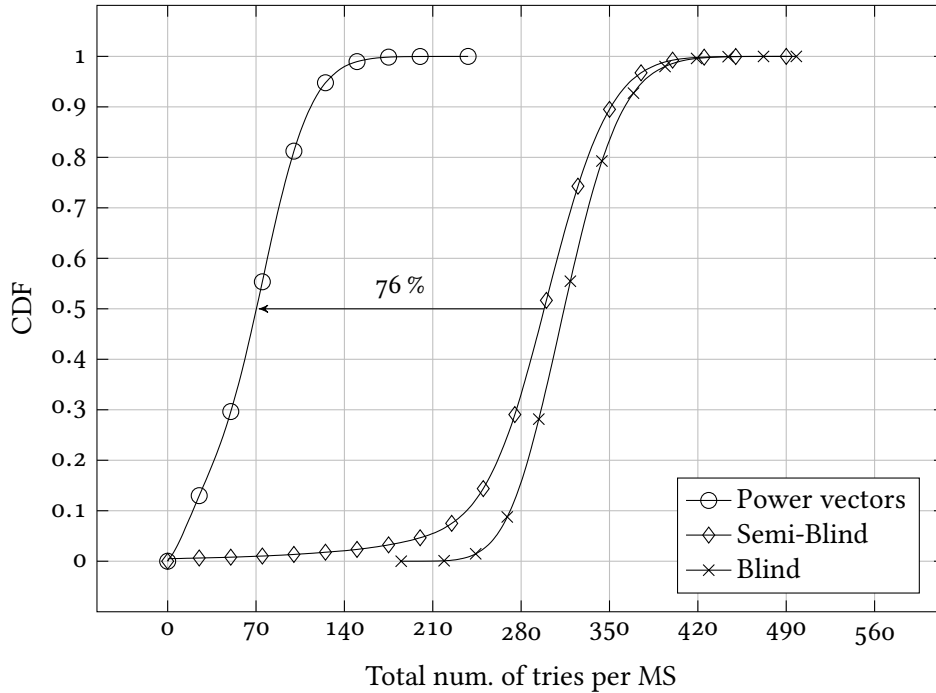

Figure 4.4: Total number of tries to detect all neighbors per MS with 64 MSs/cell.

Particularly, when compared with the semi-blind method in the 50th percentile, the number of tries are reduced about 76%. A summary for different percentiles is shown in table 4.2.

Table 4.2: Total number of tries to detect all neighbors per MS for different percentiles with 64 MSs/cell.

Method	Percentile		
	5 %	50 %	95 %
Power vectors	11	70	125
Semi-Blind	203	297	366
Blind	259	313	376

Furthermore, the complexity of the proposed method, measured by the number of tries required to detect all neighbors when the number of neighbors increases, is also significantly reduced, which is observable in the slopes of straight lines in figure 4.5. Notably, when there are around 28 neighbors per MS, less 473 tries are required to detect all neighbors in comparison with the semi-blind case.

It is worth to note that the correlation threshold influences the absolute values of the results regarding the number of tries to detect all neighbors per MS because it determines the number of potential neighbors and, along with that, the D2D links that is necessary to check to ensure that they are real neighbors (see section 4.2.3); but not the relative values when comparing the three methods because they are equally affected. Also, the D2D channel influences the number of tries to detect a single neighbor, but not relative values.

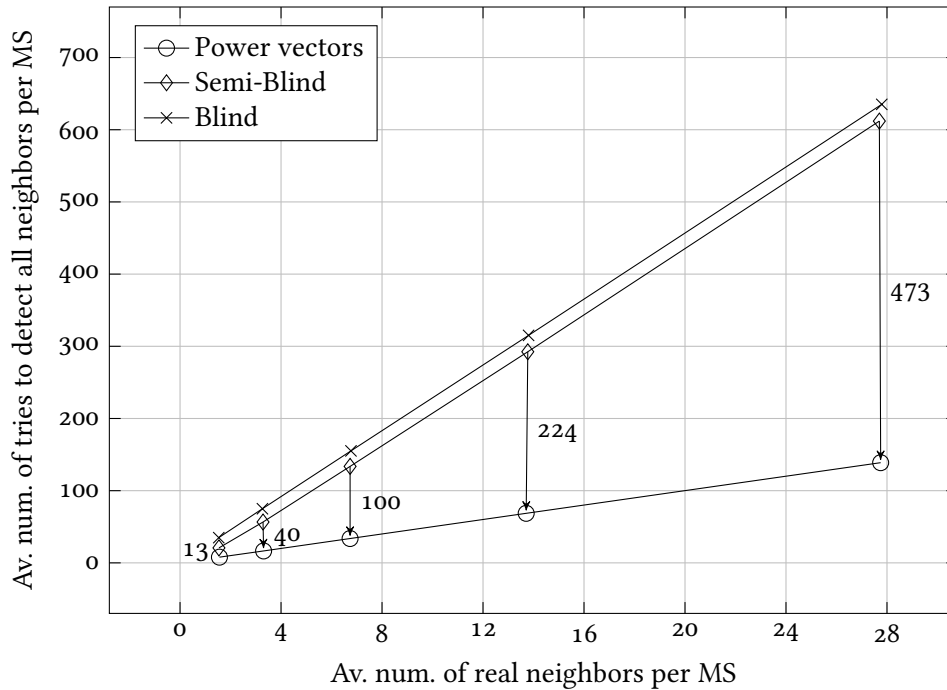

Figure 4.5: Comparison between the different methods considering the average number of tries to detect all neighbors.

## 4.5. Power Vectors and Neighborhood Matrix: Multi-Cell Scenario

In this section, the focus is given to the detailed explanation of power vectors and the construction of neighborhood matrix for the multi-cell scenario, which is a generalization of the single-cell case presented in section 4.2. For this, the explanation below is referred to figure 4.6 that presents a set of messages exchanged between BSs and D2D-capable MSs.

### 4.5.1. Scenario

Consider a certain region with  $B$  cells. Also, assume that each cell is a site and has a BS, so there exists  $B$  BSs over such area<sup>8</sup>. This corresponds to a multi-cell scenario (see figure 4.7), where all BSs are assumed to be connect though a dedicated link for data control, as the case of X2 interface in LTE family standards [108].

As previously explained, each BS knows its neighbor BSs (or cells), which are stored in a list, commonly described as NCL or monitored set. The existence of those lists is essential in any cellular network to ensure service continuity during handover or for cell-reselection procedures. Hence, each MSs is instructed to perform power measurements on the pilots of its serving BS and vicinity BSs (i.e., BSs within NCL) and report back those measurements in the UL to the serving BS<sup>9</sup>.

For illustration, suppose that a certain MS served by a BS performs a broadcast/multicast service request, e.g., sends a message that needs to reach all MSs in the neighborhood (phase 1 of figure 4.6). Also, assume that all MSs are D2D-capable and D2D communication mode is preferable over the traditional cellular mode [26], [27], [121]. In this scenario, the serving

<sup>8</sup> It may not be the case if, e.g., each site has three cells like in urban-macrocell environment [146].

<sup>9</sup> The serving BS of a MS is the BS that defines the cell coverage area where the MS is camped.

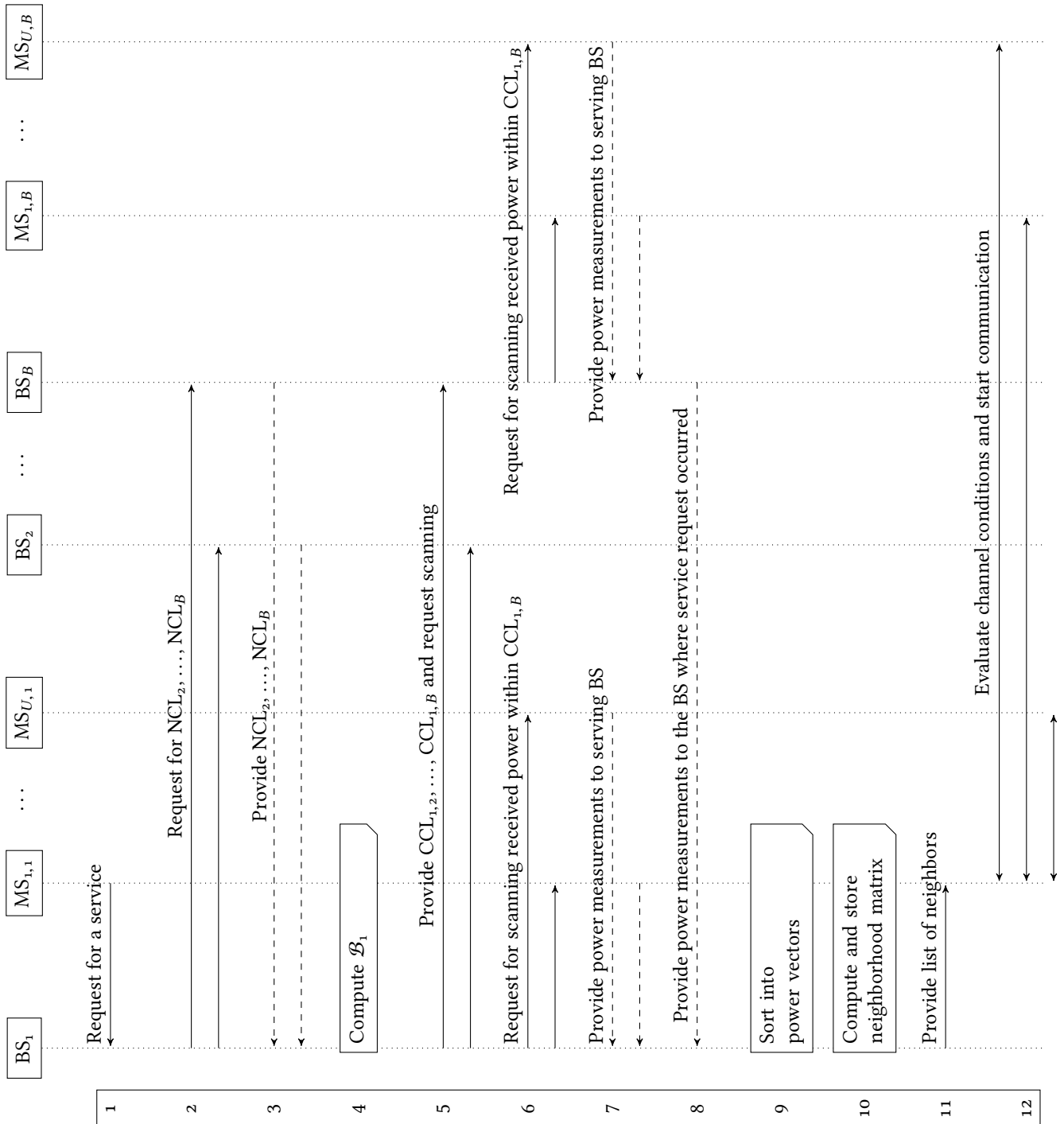

Figure 4.6: Messages exchange between BSs and D2D-capable MSs for a service request originated from MS<sub>1,1</sub>; in this particular example, it could be any other MS within the coverage area of BS<sub>1</sub>.



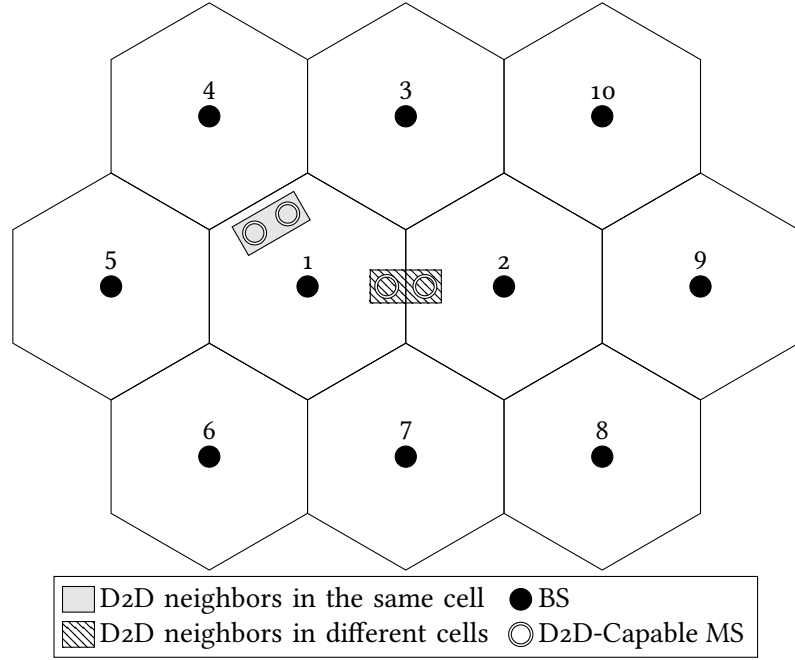

Figure 4.7: Multi-cell scenario, considering that BSs sharing borders with BS<sub>*j*</sub> belong to  $NCL_j, j \in \{1, 2, \dots, 10\}$ .

BS will compute and provide the list of candidate neighbors for the MS, so that the latter can more effectively evaluate the real channel conditions (e.g., through a simple beacon/acknowledge mechanism) with candidate neighbors ensuring they are real neighbors and start the communication.

#### 4.5.2. Preliminary Step: Building Common Cell Lists

In a multi-cell scenario, it is possible to have the representation

$$\mathbf{B} = \begin{bmatrix} b_{1,1} & b_{1,2} & \cdots & b_{1,B} \\ b_{2,1} & b_{2,2} & \cdots & b_{2,B} \\ \vdots & \vdots & \ddots & \vdots \\ b_{B,1} & b_{B,2} & \cdots & b_{B,B} \end{bmatrix}, \quad (4.6)$$

with

$$b_{i,j} = \begin{cases} 1, & \text{if } BS_i \in NCL_j \text{ and } i \neq j, \\ 0, & \text{otherwise,} \end{cases}$$

where  $\mathbf{B} \in \{0, 1\}^{B \times B}$  is a binary matrix establishing all neighborhood relations between BSs in the scenario, so that if  $b_{i,j}$  equals a logic one, then BSs  $i$  and  $j$  are neighbors and a logic zero otherwise,  $i \neq j \in \{1, 2, \dots, B\}$ ,  $BS_i$  is the  $i$ -th BS ( $i$ -th column of  $\mathbf{B}$ ), and  $NCL_j$  is the set of BSs that are neighbors of  $BS_j$  ( $j$ -th row of  $\mathbf{B}$ ). Additionally, for  $i \neq j$ ,  $BS_i \in NCL_j$  implies  $BS_j \in NCL_i$  or, in other words,  $b_{i,j} = b_{j,i}$  (phases 2 and 3 of figure 4.6).

Now, let us define Common Cell List (CCL) or intersected neighbor cell list as the set of BSs that commonly belong to (two) different NCLs; which is easy to determine using matrix  $\mathbf{B}$  from equation (4.6) because each row represents a different NCL. Thus, consider  $NCL_j$  and  $NCL_{j'}$

( $j$ -th and  $j'$ -th rows of  $\mathbf{B}$ ) from BSs  $j$  and  $j'$ , respectively. The CCL between them is given as

$$\text{CCL}_{j,j'} = \begin{cases} \text{NCL}_j \cap \text{NCL}_{j'}, & \text{if } \text{BS}_{j'} \in \text{NCL}_j, \\ \emptyset, & \text{otherwise,} \end{cases} \quad (4.7)$$

with  $j' \in \{1, 2, \dots, B\}$ . Each CCL has the following properties:

- As it is easy to see,  $\text{CCL}_{j,j'} = \text{CCL}_{j',j}$ ;
- The CCL of  $\text{BS}_j$  with itself is the  $\text{NCL}_j$ , i.e, if  $j' = j$ , then  $\text{CCL}_{j,j'} = \text{NCL}_j$ ;
- If the  $\text{CCL}_{j,j'}$  is an empty set, i.e.,  $\text{CCL}_{j,j'} = \emptyset$ , then no common pilots exist to be scanned, therefore no neighbor MSs exist between BSs  $j$  and  $j'$ .

Also, in a broadcast/multicast scenario the CCL concept can be easily extended to more than two BSs for the detection of multi-cell neighbor MSs. In this context,  $\mathcal{B}_j$  is the universe of CCLs with respect to  $\text{BS}_j$ , which for a generic  $\text{BS}_{j'} \in \text{NCL}_j$  is defined as the union of all possible CCLs (phases 4 and 5 of figure 4.6), i.e.,

$$\begin{aligned} \mathcal{B}_j &= \text{CCL}_{j,1} \cup \text{CCL}_{j,2} \cup \dots \cup \text{CCL}_{j,j} \cup \dots \cup \text{CCL}_{j,B} \\ &= (\text{NCL}_j \cap \text{NCL}_1) \cup (\text{NCL}_j \cap \text{NCL}_2) \cup \dots \cup \text{NCL}_j \\ &\quad \cup \dots \cup (\text{NCL}_j \cap \text{NCL}_B) \\ &= \bigcup_{j'=1}^B (\text{NCL}_j \cap \text{NCL}_{j'}). \end{aligned} \quad (4.8)$$

For example, the scenario in figure 4.7 has  $B = 10$  BSs. But, let us just look to BSs 1, 2, 9, and 10. Thus, matrix  $\mathbf{B}$  has the following aspect

$$\mathbf{B} = \begin{bmatrix} 0 & 1 & 1 & 1 & 1 & 1 & 1 & 0 & 0 & 0 \\ 1 & 0 & 1 & 0 & 0 & 0 & 1 & 1 & 1 & 1 \\ \vdots & \vdots & \vdots & \vdots & \vdots & \vdots & \vdots & \vdots & \vdots & \vdots \\ 0 & 1 & 0 & 0 & 0 & 0 & 0 & 1 & 0 & 1 \\ 0 & 1 & 1 & 0 & 0 & 0 & 0 & 0 & 1 & 0 \end{bmatrix},$$

or  $\text{NCL}_1 = \{2, 3, 4, 5, 6, 7\}$ ,  $\text{NCL}_2 = \{1, 3, 7, 8, 9, 10\}$ , ...,  $\text{NCL}_9 = \{2, 8, 10\}$ , and  $\text{NCL}_{10} = \{2, 3, 9\}$ . Also, assuming a service request has occurred within the coverage area of  $\text{BS}_1$ , the universe of CCLs  $\mathcal{B}_1$  is as follows

$$\begin{aligned} \mathcal{B}_1 &= \text{CCL}_{1,1} \cup \text{CCL}_{1,2} \cup \dots \cup \text{CCL}_{1,9} \cup \text{CCL}_{1,10} \\ &= \{2, 3, 4, 5, 6, 7\} \cup \{3, 7\} \cup \dots \cup \emptyset \cup \emptyset. \end{aligned}$$

#### 4.5.3. Collecting Power Measurements from Common Cell List

The  $\text{BS}_j$  where the service request had its origin then instructs its MSs and triggers a vicinity  $\text{BS}_{j'}$  to also instruct its MSs to scan the received power from the BSs within  $\text{CCL}_{j,j'}$  (phases 6, 7, and 8 of figure 4.6; where, as an example,  $\text{CCL}_{1,B}$  is the one to be scanned).

Let us denote  $\text{MS}_{u,j}$  as the MS  $u$  in the coverage area of  $\text{BS}_j$  and, for convenience, each BS serves  $U$  MSs<sup>10</sup>, i.e.,  $u \in \{1, 2, \dots, U\}$ . Therefore, the maximum number of possible neighbors is

<sup>10</sup> In fact the number of MSs per cell is less or equal to  $U$ , which implies that a certain  $\text{MS}_{u,j}$  may not even exist.

$BU - 1$ . Furthermore, the received power of each MS with respect to each BS in the scenario may be arranged as a power matrix  $\mathbf{P} \in \mathbb{R}^{(U \times B) \times B}$  like in equation (4.9), where each row represents a power vector  $\mathbf{p}_{u,j}$  (phase 9 of figure 4.6),

$$\mathbf{P} = \begin{bmatrix} \mathbf{P}_{1,1} \\ \mathbf{P}_{2,1} \\ \vdots \\ \mathbf{P}_{U,1} \\ \mathbf{P}_{1,2} \\ \mathbf{P}_{2,2} \\ \vdots \\ \mathbf{P}_{U,2} \\ \vdots \\ \mathbf{P}_{1,B} \\ \mathbf{P}_{2,B} \\ \vdots \\ \mathbf{P}_{U,B} \end{bmatrix} = \begin{bmatrix} p_{(1,1),1} & p_{(1,1),2} & \cdots & p_{(1,1),B} \\ p_{(2,1),1} & p_{(2,1),2} & \cdots & p_{(2,1),B} \\ \vdots & \vdots & \ddots & \vdots \\ p_{(U,1),1} & p_{(U,1),2} & \cdots & p_{(U,1),B} \\ p_{(1,2),1} & p_{(1,2),2} & \cdots & p_{(1,2),B} \\ p_{(2,2),1} & p_{(2,2),2} & \cdots & p_{(2,2),B} \\ \vdots & \vdots & \ddots & \vdots \\ p_{(U,2),1} & p_{(U,2),2} & \cdots & p_{(U,2),B} \\ \vdots & \vdots & \ddots & \vdots \\ p_{(1,B),1} & p_{(1,B),2} & \cdots & p_{(1,B),B} \\ p_{(2,B),1} & p_{(2,B),2} & \cdots & p_{(2,B),B} \\ \vdots & \vdots & \ddots & \vdots \\ p_{(U,B),1} & p_{(U,B),2} & \cdots & p_{(U,B),B} \end{bmatrix}, \quad (4.9)$$

and

$$p_{(u,j),b} = \begin{cases} p_{(u,j),b}, & \text{if MS}_{u,j} \text{ exists and BS}_b \in \text{CCL}_{j,j'}, \\ 0, & \text{otherwise,} \end{cases}$$

whither  $p_{(u,j),b}$  represents the received power of  $\text{MS}_{u,j}$  from  $\text{BS}_b$ ,  $b \in \{1, 2, \dots, B\}$ ; or using other words, for MSs served by  $\text{BS}_j$  or  $\text{BS}_{j'}$ , the received power from  $\text{BS}_b$  only has significance if  $\text{BS}_b$  belongs to  $\text{CCL}_{j,j'}$ . Moreover,  $\mathbf{P}_j \in \{\mathbf{P}_1, \mathbf{P}_2, \dots, \mathbf{P}_B\}$  represent the power sub-matrices in the coverage area of  $\text{BS}_1, \text{BS}_2, \dots, \text{BS}_B$ , i.e., the single-cell scenario, as in section 4.2.

Whenever the received power for a specific BS cannot be measured by a certain MS, due to any particular reason, a standard value can be used to fill the corresponding gap in the power vector so that the method is still applicable. Further, in order to not bias/polarize the results, the received power from the serving BS shall be nullified from the power vector of each MS because the order of magnitude of the received power is noticeable higher than the one received from vicinity BSs; with the previous formulation if  $b = j' = j$  then  $p_{(u,j),b} = 0$ .

The matrix  $\mathbf{P}$ , as presented before, can be seen as a distributed database (in each BS) and used as required. For example, older values may be ignored or replaced by new measurements and the exchanging of parts of  $\mathbf{P}$  between BSs can be done in accordance with the changes since last update, therefore reducing signaling. Also, in principle, the matrix  $\mathbf{P}$  is composed by sparse vectors (with lot of zeros, depending on the number of BSs to be scanned), which may be used to improve the correlation metric calculation, presented in section 4.5.4.

#### 4.5.4. Building the Neighborhood Matrix

The determination of neighbors between MSs served by  $\text{BS}_j$  and  $\text{BS}_{j'}$  (phase 10 of figure 4.6) is an iterative process as shown in figure 4.8.

However, some comments about the more important steps must be done:

- Steps 3 and 4: filtered means that only values measured from BSs within  $\text{CCL}_{j,j'}$  shall appear in sub-matrices  $\mathbf{P}_j$  and  $\mathbf{P}_{j'}$  and other values set to zero;

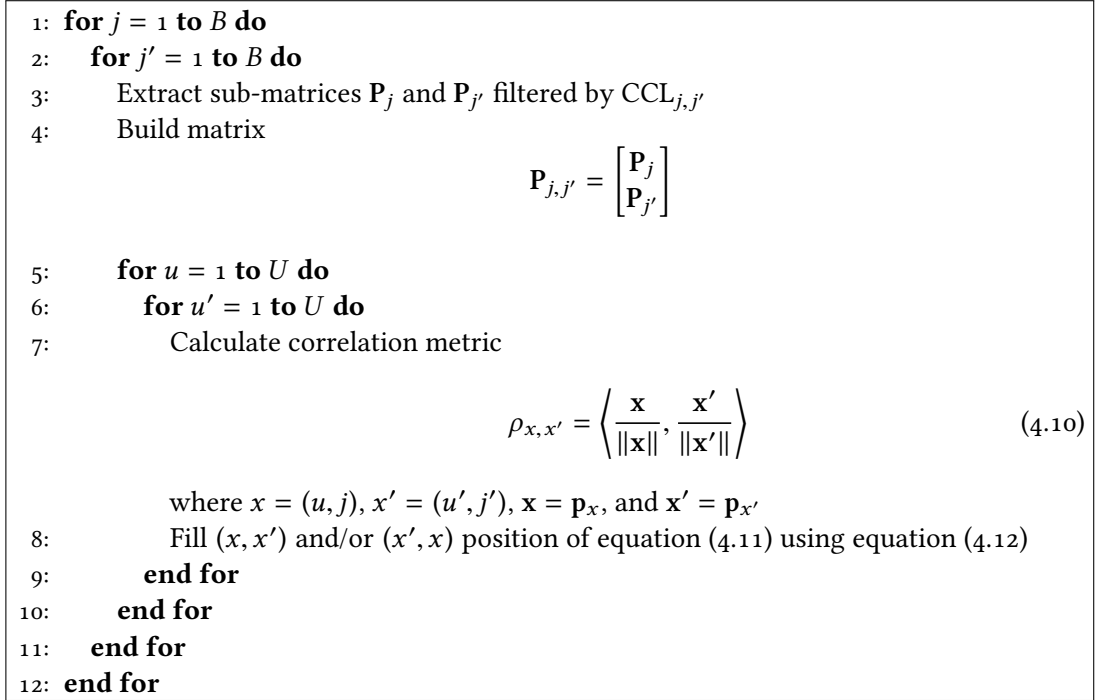

Figure 4.8: Iterative process for building the neighborhood matrix.

- Step 7: the correlation metric in equation (4.10), expressed as the normalized inner product ( $\langle \cdot, \cdot \rangle$  is the inner product and  $\|\cdot\|$  is the  $l_2$  norm), can be any other that measures the degree of similarity between two different power vectors. Additionally, since power vectors  $\mathbf{p}_{u,j}$  and  $\mathbf{p}_{u',j'}$  are composed by non-negative quantities,  $\rho_{(u,j),(u',j')}$  will range between zero (non-correlated) and one (very high correlated);
- Step 8: the neighborhood relations between all MSs in the scenario is the so-called neighborhood matrix  $\Omega \in [0, 1]^{(U \times B) \times (U \times B)}$  presented in equation (4.11). This is a symmetric matrix, i.e., values in  $((u, j), (u', j'))$  and  $((u', j'), (u, j))$  are equal, thus only the lower or upper triangles may be used, e.g., for saving storage space. Also, sub-matrix  $\Omega_{j,j'} = \Omega_{j',j}^T$  (where  $(\cdot)^T$  is the transpose operation) translates the neighborhood relation between the MSs served by  $\text{BS}_j$  and  $\text{BS}_{j'}$ .

$$\Omega = \begin{array}{c} \begin{array}{c} \Omega_{1,1} \\ \mathcal{W}_{(1,1),(1,1)} \quad \mathcal{W}_{(1,1),(2,1)} \quad \cdots \quad \mathcal{W}_{(1,1),(U,1)} \quad \cdots \quad \mathcal{W}_{(1,1),(1,B)} \quad \mathcal{W}_{(1,1),(2,B)} \quad \cdots \quad \mathcal{W}_{(1,1),(U,B)} \\ \mathcal{W}_{(2,1),(1,1)} \quad \mathcal{W}_{(2,1),(2,1)} \quad \cdots \quad \mathcal{W}_{(2,1),(U,1)} \quad \cdots \quad \mathcal{W}_{(2,1),(1,B)} \quad \mathcal{W}_{(2,1),(2,B)} \quad \cdots \quad \mathcal{W}_{(2,1),(U,B)} \\ \vdots \quad \vdots \quad \ddots \quad \vdots \quad \cdots \quad \vdots \quad \vdots \quad \ddots \quad \vdots \\ \mathcal{W}_{(U,1),(1,1)} \quad \mathcal{W}_{(U,1),(2,1)} \quad \cdots \quad \mathcal{W}_{(U,1),(U,1)} \quad \cdots \quad \mathcal{W}_{(U,1),(1,B)} \quad \mathcal{W}_{(U,1),(2,B)} \quad \cdots \quad \mathcal{W}_{(U,1),(U,B)} \\ \mathcal{W}_{(1,2),(1,1)} \quad \mathcal{W}_{(1,2),(2,1)} \quad \cdots \quad \mathcal{W}_{(1,2),(U,1)} \quad \cdots \quad \mathcal{W}_{(1,2),(1,B)} \quad \mathcal{W}_{(1,2),(2,B)} \quad \cdots \quad \mathcal{W}_{(1,2),(U,B)} \\ \mathcal{W}_{(2,2),(1,1)} \quad \mathcal{W}_{(2,2),(2,1)} \quad \cdots \quad \mathcal{W}_{(2,2),(U,1)} \quad \cdots \quad \mathcal{W}_{(2,2),(1,B)} \quad \mathcal{W}_{(2,2),(2,B)} \quad \cdots \quad \mathcal{W}_{(2,2),(U,B)} \\ \vdots \quad \vdots \quad \ddots \quad \vdots \quad \cdots \quad \vdots \quad \vdots \quad \ddots \quad \vdots \\ \mathcal{W}_{(U,2),(1,1)} \quad \mathcal{W}_{(U,2),(2,1)} \quad \cdots \quad \mathcal{W}_{(U,2),(U,1)} \quad \cdots \quad \mathcal{W}_{(U,2),(1,B)} \quad \mathcal{W}_{(U,2),(2,B)} \quad \cdots \quad \mathcal{W}_{(U,2),(U,B)} \\ \Omega_{B,1} \quad \vdots \quad \vdots \quad \vdots \quad \ddots \quad \Omega_{B,B} \quad \vdots \quad \vdots \quad \vdots \quad \vdots \\ \mathcal{W}_{(1,B),(1,1)} \quad \mathcal{W}_{(1,B),(2,1)} \quad \cdots \quad \mathcal{W}_{(1,B),(U,1)} \quad \cdots \quad \mathcal{W}_{(1,B),(1,B)} \quad \mathcal{W}_{(1,B),(2,B)} \quad \cdots \quad \mathcal{W}_{(1,B),(U,B)} \\ \mathcal{W}_{(2,B),(1,1)} \quad \mathcal{W}_{(2,B),(2,1)} \quad \cdots \quad \mathcal{W}_{(2,B),(U,1)} \quad \cdots \quad \mathcal{W}_{(2,B),(1,B)} \quad \mathcal{W}_{(2,B),(2,B)} \quad \cdots \quad \mathcal{W}_{(2,B),(U,B)} \\ \vdots \quad \vdots \quad \ddots \quad \vdots \quad \cdots \quad \vdots \quad \vdots \quad \ddots \quad \vdots \\ \mathcal{W}_{(U,B),(1,1)} \quad \mathcal{W}_{(U,B),(2,1)} \quad \cdots \quad \mathcal{W}_{(U,B),(U,1)} \quad \cdots \quad \mathcal{W}_{(U,B),(1,B)} \quad \mathcal{W}_{(U,B),(2,B)} \quad \cdots \quad \mathcal{W}_{(U,B),(U,B)} \end{array} \end{array}, \quad (4.11)$$

with

$$\mathcal{w}_{(u,j),(u',j')} = \begin{cases} \rho_{(u,j),(u',j')}, & \text{if } (u',j') \neq (u,j) \text{ and } \rho_{(u,j),(u',j')} > P_{\text{TH}}, \\ 0, & \text{otherwise.} \end{cases} \quad (4.12)$$

Now, looking exclusively to equation (4.12) and defining a correlation threshold,  $P_{\text{TH}}$  (between zero and one), two cases may happen:

- Correlation is high:  $\rho_{(u,j),(u',j')} > P_{\text{TH}}$ . As such,  $\text{MS}_{u,j}$  and  $\text{MS}_{u',j'}$ , i.e.,  $\text{MS}_u$  of  $\text{BS}_j$  and  $\text{MS}_{u'}$  of  $\text{BS}_{j'}$ , are considered neighbors because their set of measurements is very similar and, therefore, it is likely to happen that they are in physical proximity<sup>11</sup>;
- Correlation is low:  $\rho_{(u,j),(u',j')} \leq P_{\text{TH}}$ . Thus,  $\text{MS}_{u,j}$  and  $\text{MS}_{u',j'}$  are not considered as neighbors because their set of measurements is not similar and, therefore, it is likely to happen that they are far way from each other.

As said before, conventionally MSs are instructed to perform measurements within the NCL of their serving BS. In the formulation above, this concept is taken further and MSs should in principle measure the received power from all  $B$  BSs within the considered scenario, or at least in  $\mathcal{B} = \{\mathcal{B}_1 \cup \mathcal{B}_2 \cup \cdots \cup \mathcal{B}_B\}$ . Note that  $\#\mathcal{B} \leq B$ , where  $\#\{\cdot\}$  is the cardinality (number of elements) of a set  $\{\cdot\}$ .

However, a full scanning in the whole “universe”, that is time consuming and can completely drain MS’s battery, may not be required depending on the type of service request. In fact, it may be restricted to  $\mathcal{B}_j$  (of  $\text{BS}_j$ ) or even just few of its CCLs, as illustrated in figure 4.6, presuming that a service request was originated from  $\text{MS}_{1,1}$  (first MS of first cell) of figure 4.7.

#### 4.5.5. Storage and Exchange of Neighborhood Matrix

The neighborhood matrix that was constructed may be stored in each BS and provided to the MS upon request (phase 11 of figure 4.6), so that it can evaluate the D2D link before commencing a D2D communication (phase 12 of figure 4.6).

Moreover, regarding the running time for message exchange (excluding phase 1), it can be settled in the following basis:

<sup>11</sup> See footnote 5.

- Phases 2 to 8: may be done at every 200 ms to 1 s, or 200 to 1000 TTIs [143];
- Phases 9 to 12: may be done at each new service request or whenever the MS is scheduled.

## 4.6. Conclusion

In this chapter we proposed and explained a neighbor discovery process based on power vectors for network-assisted D2D communications. The method may be used in current wireless systems because it uses the already available measurements and does not add considerable network load on signaling. First the method was presented for a single-cell scenario and latter extended for the multi-cell case.

In the single-cell scenario, results show that with the network help, the time to detect all neighbors per MS is significantly reduced, letting more time for data transmission. For the multi-cell case results are not expected to change much. Nevertheless, the effort to compute the neighborhood matrix tends to increase as the number of BSs increases, which is likely to happen in a Fifth Generation (5G) scenario with network densification, especially the spatial densification [150]. On the other side, if the number of BSs (i.e., the cardinality of a CCL between two BSs) is low, the quality of the cross correlation metric can be compromised.

The proposed method is able to operate in Frequency Division Duplex (FDD) and Time Division Duplex (TDD) modes and is not dependent on the radio access technology. Moreover, and especially, it overcomes the problems presented in section 4.1.2, in the following manner:

- Time to discover and stopping criteria: given that a set of neighbors is built at the BS, the number of MS neighbors becomes known and, therefore, the time to discover is just the time to evaluate the real channel conditions for the D2D links of the candidate neighbors, as well as the stopping criteria, i.e., the criteria that sets when the discovery process shall stop, can be better defined/adjusted;
- Power management: the MS power that is consumed in the discovery process is lower because the main work is done at the BS, building the neighborhood relations, which for each MS is considered to be a small set. Thus, just before the session establishment, the MS just needs to ensure that D2D communication can be established through the direct channel, which can be done, e.g., by a single pair of beacon/acknowledgement packets;
- New protocol implementation: no new protocol is required to be implemented for the measurement process because signal quality measurements are already available/exchanged in the network and are mandatory for it to operate. Also, BSs are connected through a dedicated link for data control, so no new link is required. However, three new types of messages will be required: for exchanging the NCL lists between BSs; for the range of BSs to be scanned; and for each BS to inform the neighbor candidate list to each MS;
- *Hidden MS problem*: this problem will simply not exist. Building the neighborhood matrix is a centralized process and since the BS is aware of any D2D direct communication that is ongoing, if any candidate neighbor is potentially seen as “hidden”, it may be just removed from the neighborhood matrix, therefore avoiding the problem;
- The multi-cell cases, i.e., MSs that belong to different cells (served by different BSs) are able to discover each other, enabling the cross-cell border D2D communications;
- The NCL of each BS may be especially large, e.g., in crowded areas where the deployment is based on small cells. With the introduction of CCL concept, the number of BSs to

be scanned for each MS is limited, which reduces the power wasted in the scanning, therefore improving the MS' batteries lifetime.

Finally, future works on this topic may focus on:

- Simulate the discovery of MSs that belong to different cells (served by different BSs), which may happen close to cell boundaries;
- Implement a timeout for the discover to happen (detection window) and count the false/missed detections;
- Discover neighbors that do not fulfill the service request, which can be especially useful in social networks;
- Evaluate the proposed method based on power vectors in real cellular networks underlaid by D2D communications.

## CHAPTER 5

---

### Band Selection for D2D Communications

---

**F**or systems with reuse factor less than one, the co-channel interference can drastically reduce the gain of primary networks, which limits the whole system performance. This chapter exploits the selection of Downlink (DL) or Uplink (UL) band to be reused by a Device-to-Device (D2D) link. The band selected by the method is based on a radio distance metric, such as received power. Despite being a simple concept, results have shown that band selection can effectively mitigate the interference caused by D2D communications in a Long Term Evolution (LTE) network. Therefore, the coexistence of cellular and D2D communication modes becomes possible in time, frequency, and space.

#### 5.1. Introduction

As mentioned in chapter 1, D2D communication is a type of direct wireless communication between two or more network nodes, hereafter generally referred as User Equipments (UEs), similar to direct-mode operation in professional mobile radio systems or the bluetooth technology, that has attracted increasing attention of the scientific community in the last couple of years, mostly because of its flexibility [26]: D2D communications can be deployed in Industrial, Scientific and Medical (ISM) bands for the unlicensed spectrum use, such as Wireless Local Area Networks (WLANs), or in cellular networks for a licensed use [27].

D2D communications are particularly attractive considering the reuse gain obtained when D2D-capable UEs are allowed to directly transmit data by reusing either DL or UL radio resources from the cellular network [32]. However, operating in the in-band shared spectrum mode [44], secondary D2D communications pose new challenging interference situations, such as the co-channel interference, due to orthogonality loss [33], which can drastically reduce the performance of primary cellular communications [52].

Some of the already studied solutions to deal with this problem and improve the overall network throughput include, e.g., power control, spatial diversity, robust centralized/distributed resource allocation, mode selection and grouping, or network coding [32], [44] (recall figure 1.4). In this chapter we investigate the interference mitigation by using an intelligent selection of the transmission band, either DL or UL, for the D2D link when sharing spectrum resources with an LTE network. Nevertheless, the method is still valid for a time-based duplexing scheme and other types of wireless systems. Also, differently from most of state of the art publications that focus on interference mitigation, herein we consider a realistic multi-user/cell scenario, with wrap-around, and both communication directions.

The remaining sections of this chapter are organized as follows: in section 5.2 the principle behind band selection technique is presented and explained in detail, section 5.3 has the



description of system models used for simulations, in section 5.4 the principal results are shown and analyzed, lastly conclusions are drawn in section 5.5.

## 5.2. Band Selection

### 5.2.1. Overview

The main principle behind band selection for interference mitigation is to either select DL or UL band for the D2D link using a radio distance metric, like the received power,  $pr$ . The decision-taking procedure verifies if the received power from the serving Evolved Node B (eNB) of the transmitter within the D2D pair<sup>1</sup> is above a given threshold,  $Pr_{TH}$ , and if it yields true, the DL band is selected; otherwise, the UL band is used, as presented in figure 5.1.

The  $pr$  is measured from the serving eNB (eNB-UE link), not within the D2D pair (UE-UE link), and attempts to map the position of the interferer (D2D-capable UE that acts as transmitter) within the cell, since the real location is most of the times unavailable (see figure 5.2). The higher is the received power, the lower is the distance to eNB. Thus, above threshold means “near eNB”, while below the threshold translates “at cell-edge” position (see figure 5.3).

Furthermore, the method must be applied for all D2D pairs in each Transmission Time Interval (TTI) because of channel variations. Also, we refer as active pairs the ones with the same selected band as the current communication phase, i.e., reuse DL band in DL phase or reuse UL band in the UL phase.

For LTE networks, the band selection technique is performed per Physical Resource Block (PRB) and also includes the grouping of one active pair (selected randomly or by any other mean) with the primary scheduled cellular UE to either reuse the DL or UL PRBs (see figure 5.5). In this situation, system-specific measurements like Reference Signal Received Power (RSRP), Received Signal Strength Indicator (RSSI), or even Reference Signal Received Quality (RSRQ) may be used alone or combined to be the radio distance metric.

### 5.2.2. The Underlying Concept

Consider the picture in figure 5.2, where  $h$  and  $g$  denote the complex channel coefficients, respectively associated with desired and interfering gains. These channels are assumed to be asymmetric, i.e., DL and UL channels may have different gains. The simplified scenario represented therein also suffers outside interference from the surrounding cells that are using the same PRB. That interference channel can be generally designated as  $i_k$ , where  $k$  refers to the index of the interferer  $I_k$  (eNB or UE). Also, each receiver is subject to experience additive white Gaussian noise  $n_3, n_4 \sim \mathcal{CN}(0, \sigma^2)$ . Moreover, the transmitted data symbols are represented as  $x$ , and we assume that  $|x_1|^2 = |x_3|^2 = |x_4|^2 = |x_{I_k}|^2 = 1$ . Thereby, the received signals at

<sup>1</sup> A pair formed by two D2D-capable UEs (transmitter and receiver) that use the direct path to communicate.

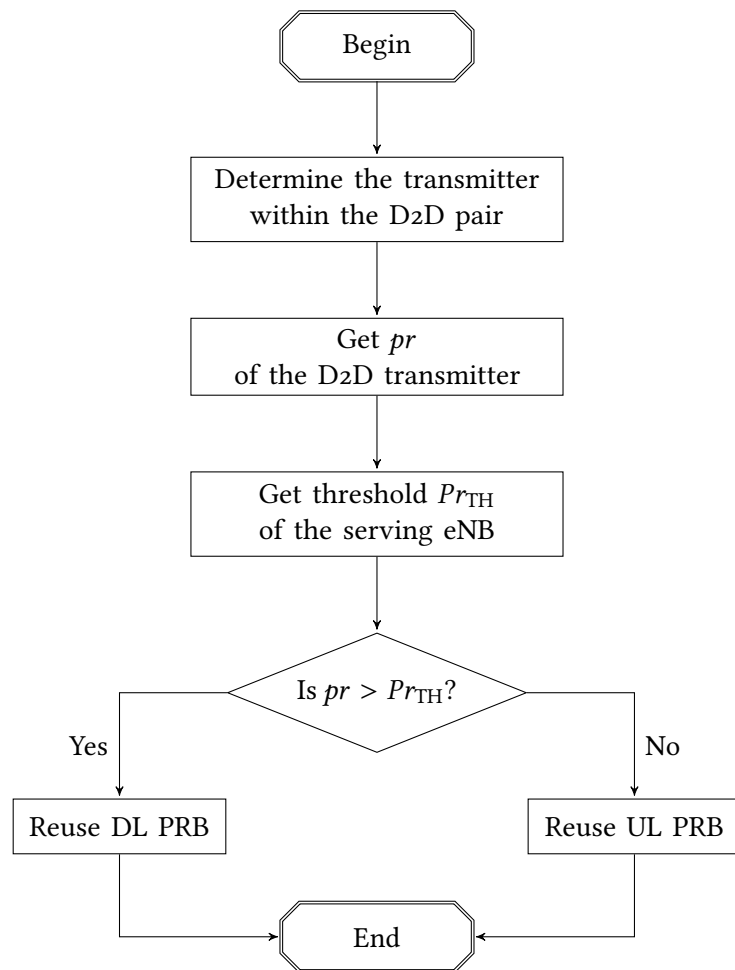

Figure 5.1: Band selection technique for LTE networks, that shall be performed by eNBs, for all D2D pairs.

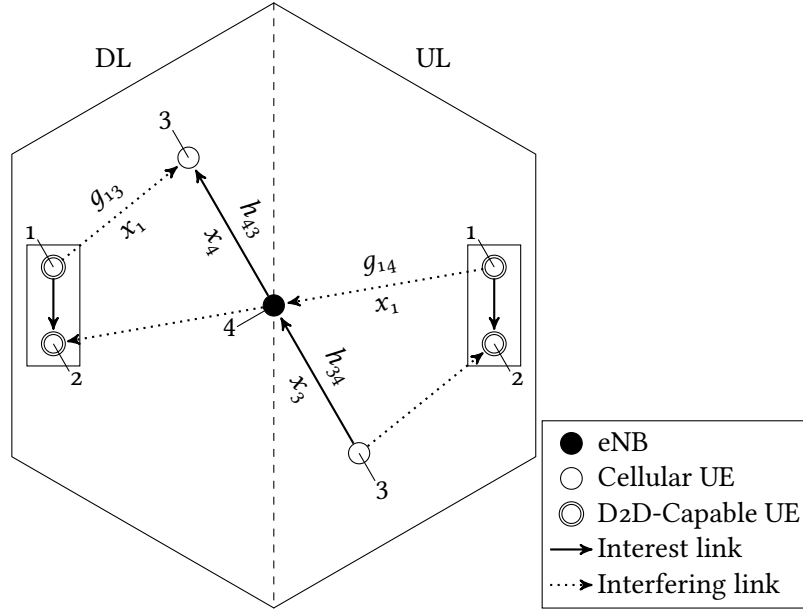

Figure 5.2: Simplified scenario illustrating the urban-microcell environment with hotspot for DL and UL communication directions: sources 1, 3, and 4 transmit signals  $x_1$ ,  $x_3$ , and  $x_4$  with power  $p_1$ ,  $p_3$ , and  $p_4$ , respectively;  $h_{34}$  and  $h_{43}$  represent the channel between sources 3 and 4 in both directions, while  $g_{13}$  and  $g_{14}$  represent the interfering channels because of D2D communication originated from source 1.

sources 3 and 4 are given as follows

$$y_3 = \underbrace{\sqrt{p_4}h_{43}x_4}_{\text{desired signal}} + \underbrace{\sum_k \sqrt{p_{I_k}}i_k x_{I_k}}_{\text{outside interf. signal}} + \underbrace{\sqrt{p_1}g_{13}x_1}_{\text{D2D interf. signal}} + n_3,$$

$$y_4 = \underbrace{\sqrt{p_3}h_{34}x_3}_{\text{desired signal}} + \underbrace{\sum_k \sqrt{p_{I_k}}i_k x_{I_k}}_{\text{outside interf. signal}} + \underbrace{\sqrt{p_1}g_{14}x_1}_{\text{D2D interf. signal}} + n_4.$$

Taking the power ratio of desired signal over the interference and noise, the Signal to Interference-plus-Noise Ratio (SINR) values at sources 3 and 4 are calculated as

$$\gamma_3 = \frac{p_4|h_{43}|^2}{\sum_k p_{I_k}|i_k|^2 + p_1|g_{13}|^2 + \sigma^2} = \frac{|h_{43}|^2}{\frac{\sum_k p_{I_k}|i_k|^2}{p_4} + \frac{p_1}{p_4}|g_{13}|^2 + \frac{\sigma^2}{p_4}}, \quad (5.1)$$

$$\gamma_4 = \frac{p_3|h_{34}|^2}{\sum_k p_{I_k}|i_k|^2 + p_1|g_{14}|^2 + \sigma^2} = \frac{|h_{34}|^2}{\frac{\sum_k p_{I_k}|i_k|^2}{p_3} + \frac{p_1}{p_3}|g_{14}|^2 + \frac{\sigma^2}{p_3}}. \quad (5.2)$$

Our goal is to reduce the interference that comes from D2D communications (the outside interference is hard to be avoided) so that the SINR is higher.

In DL all PRBs available within the cell,  $N_{\text{PRB}}$ , are used, and in UL the PRBs per UE depend on the scheduling policy. Hence,  $p_4 = P_{\text{eNB}}/N_{\text{PRB}}$  and  $P_{\text{UE}}/N_{\text{PRB}} \leq p_1, p_3 \leq P_{\text{UE}}$ , where  $P_{\text{eNB}}$  and

$P_{\text{UE}}$  are the total transmit power of eNB and UEs, respectively. In addition, normally  $p_3, p_4 \gg \sigma^2$ , which makes the system being interference limited, i.e.,  $\sigma^2/p_4 \approx 0$  and  $\sigma^2/p_3 \approx 0$ .

Now, let us assume the worst case scenario<sup>2</sup>, where: (a) The D2D transmitter is always close to the cellular receiver, either eNB in UL phase or cellular UE in DL phase, being the dominant interferer; (b) So interfering channel is always good, i.e.,  $|g_{13}|^2 \rightarrow 1^-$  and  $|g_{14}|^2 \rightarrow 1^-$  (or 0 dB).

Regarding the phases in communication, four situations may happen: we are in DL and the cellular UE is near eNB (ST1) or the cellular UE is at cell-edge (ST2); or we are in UL and the cellular UE is near eNB (ST3) or the cellular UE is at cell-edge (ST4). Without loss of generality, let us just focus on the urban-microcell scenario with a bandwidth of 5 MHz. Thus,  $P_{\text{eNB}} - P_{\text{UE}} = 14$  dB ( $P_{\text{eNB}}$  is around 25 times greater than  $P_{\text{UE}}$ ) and  $N_{\text{PRB}} = 25$  PRBs [147]. As such, the order of magnitude for desired signals and D2D-generated interference in equations (5.1) and (5.2) is heuristically compared as follows

ST1:	$ h_{43} ^2 \rightarrow 1^-$ ;	$0.04 \lesssim (p_1/p_4) g_{13} ^2 \lesssim 1$ ;	$\Rightarrow$ reuse DL
ST2:	$ h_{43} ^2 \rightarrow 0^+$ ;	$0.04 \lesssim (p_1/p_4) g_{13} ^2 \lesssim 1$ ;	$\Rightarrow$ reuse UL
ST3:	$ h_{34} ^2 \rightarrow 1^-$ ;	$0.04 \leq (p_1/p_3) g_{14} ^2 \leq 25$ ;	$\Rightarrow$ reuse DL
ST4:	$ h_{34} ^2 \rightarrow 0^+$ ;	$0.04 \leq (p_1/p_3) g_{14} ^2 \leq 25$ ;	$\Rightarrow$ reuse DL

Clearly, for the ST2, ST3, and ST4 situations, selecting an orthogonal band, i.e.,  $|g_{13}|^2 = |g_{14}|^2 = 0$ , shall represent a huge impact, reducing the overall interference suffered by the cellular receiver. For ST1, since the cellular (desired) channel is good and  $(p_1/p_4)|g_{13}|^2$  is most of the times less than the unity, there is no particular need to select an orthogonal band. As a summary, regardless the communication direction, the band selection principle does apply: if D2D communications happen close to eNB (ST1, ST3, and ST4) then the DL band is reused, otherwise the UL band is reused (ST2).

### 5.2.3. Setting the Threshold

The selection of any band is dependent on the established threshold for each eNB,  $P_{r_{\text{TH}}}$ . A possible approach, only considering large scale fading effects (path loss and shadowing), is to define a band factor  $\alpha \in [0, 1]$  which is multiplied by the cell radius (cell radius fraction). The received power at that new distance from eNB is the new threshold, as shown in figure 5.3 and detailed in algorithmic form in figure 5.4. In real networks, a campaign of field measures can be used instead, where by following the trial and error strategy described below, different best thresholds are set, depending on the place where D2D communications happen.

By turning on the band selection technique, the D2D-generated interference on cellular communications is reduced as they become protected. In such conditions, the cellular gain increases which inevitably is reflected in an increased cellular interference on D2D communications, reducing the D2D gain. Hence, a best threshold shall be selected so that the whole system benefits from both communication modes.

For that, the band factor  $\alpha$  is varied and thresholds are set for each eNB and all PRBs. Next, the band selection method is applied at every TTI, and the system performance results collected for both cellular and D2D communications in DL and UL. Let us denote  $\Psi$  as the system performance with D2D communications enabled but without band selection, and  $\Phi_j$  as the system performance with both D2D communications and band selection enabled for  $\alpha_j$

<sup>2</sup> It can be very restrictive, but while proved for the worst case scenario, it is proved for all other cases.

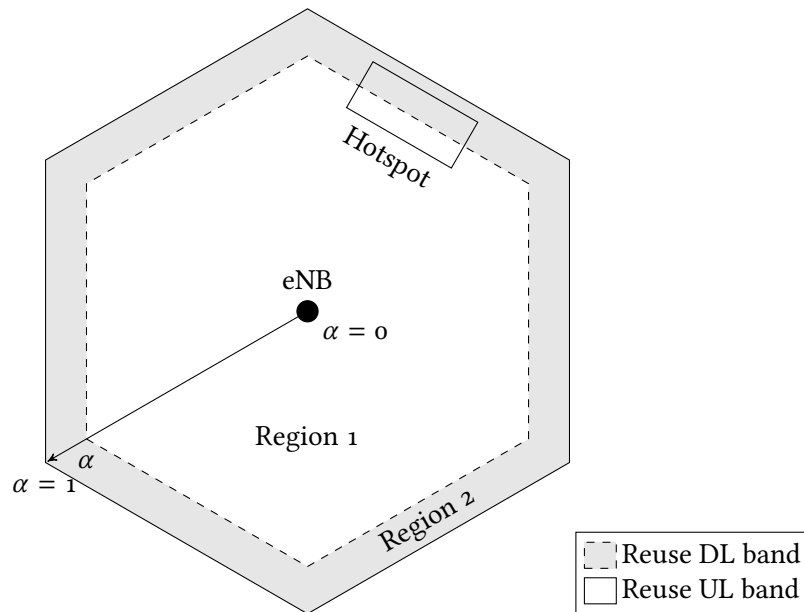

Figure 5.3: Variation of eNB threshold according the band factor  $\alpha$ : region 1 means “near eNB” thus DL band is reused, and region 2 translates in “at cell-edge” therefore UL band is reused.

```

1: for each cell do
2:   Get eNB index and cell radius
3:   Set band factor  $\alpha$ 
4:   Calculate new distance:  $\alpha$  (times) cell radius
5:   for each PRB do
6:     Get transmitted power
7:     Calculate received power at new distance, with the large scale fading effects
8:     Save received power in a (eNB index, PRB) matrix
9:   end for
10: end for

```

Figure 5.4: Set threshold for band selection based on received power.

(the communication direction and mode were omitted in the notation for simplicity). So the best band factor  $\alpha^*$  is obtained as follows

$$\alpha^* = \arg \max_j \left( \frac{C_j}{D_j} \right), \forall \alpha_j, \quad (5.3)$$

where, for  $\alpha_j$ ,

$$C_j = \max(|\Psi - \Phi_j|_{\text{DL}}, |\Psi - \Phi_j|_{\text{UL}})_{\text{cell}}, \quad (5.4)$$

$$D_j = \max(|\Psi - \Phi_j|_{\text{DL}}, |\Psi - \Phi_j|_{\text{UL}})_{\text{D2D}}, \quad (5.5)$$

and

$$A = \{0, 0.1, \dots, 1\} \text{ and } j = 1, 2, \dots, \#A \text{ and } \alpha_j \in A.$$

In the case of cellular communications we desire to maximize  $C_j$  (equation (5.4)), i.e., find  $(\Phi_j)_{\text{cell}} \gg \Psi_{\text{cell}}$ , because on such situation the gain provided by cellular communications is maximum in the presence of D2D communications. On the other hand, when band selection is not enabled, the gain of D2D communications is maximum, but they have strong impact on cellular communications; thus maximizing  $D_j$  (equation (5.5)), i.e., finding  $(\Phi_j)_{\text{D2D}} \ll \Psi_{\text{D2D}}$ , is the same as minimizing the D2D gain or the generated interference. The best trade-off between system performance and interference mitigation is then ensured by maximizing the ratio  $C_j/D_j$ , as presented in equation (5.3).

### 5.3. System Model and Simulation Framework

In previous sections a simplified signal model was used. In this one, realistic models that were employed to evaluate the system performance are described. Hence, consider an LTE-like network based on the urban-microcell propagation environment, where each eNB is placed in the center of a site (a single-cell) represented regular hexagon [146]. This scenario corresponds to a multi-cell network with  $N_{\text{cell}}$  cells regularly distributed over it and each cell serves  $N_{\text{UE}}$  UEs.

Also, there is a hotspot per cell where D2D communications happen. A percentage of the total number of UEs within the cell is clustered inside the hotspot zone while the remaining UEs are uniformly distributed over the cell area. Moreover, the D2D pairs are obtained by a simple random pairing of UEs inside the hotspot. However, in our model, UEs within the hotspot may be chosen by the scheduling policy at each TTI, therefore acting as cellular UEs. figure 5.2 exemplifies both cellular and D2D communications.

The modeling of complex channel coefficients follow a PRB basis, including the propagation effects on wireless channels, namely, pathloss, shadowing, and fast fading [146], [147], [151]. Additionally, we consider a number of  $N_{\text{PRB}}$  PRBs available in each link direction (determined by the system bandwidth) that can be fully reused by all cells. Furthermore, the channel response for each PRB is represented by the complex channel coefficient associated with its middle subcarrier and first Orthogonal Frequency Division Multiplexing (OFDM) symbol; and the channel coherence bandwidth is assumed to be larger than the bandwidth of a PRB, leading to a flat fading channel over each of them.

Due to practical reasons, subcarriers are grouped in blocks of 12 adjacent subcarriers spaced by 15 kHz, which gives a total bandwidth of 180 kHz per block. At each TTI or 1 ms, information

is conveyed on that bandwidth over 7 OFDM symbols (one slot that lasts for 0.50 ms) and is modeled for transmission. This frequency-time block is designated as PRB and is the minimum allocable unit that can be scheduled in LTE networks. However, and because of scheduling constraints, a scheduled UE takes 14 OFDM symbols, i.e., two slots or a subframe [115].

As presented in figure 5.5, after one cellular UE is selected by the Proportional Fair (PF) [53], [152] cellular scheduling policy, one D2D pair inside the hotspot is randomly grouped with the former UE to share the same PRB, in the predetermined DL or UL band. Moreover, after scheduling, the total transmit power of eNB in DL and cellular UE in UL, and D2D transmitter in both communication directions, is equally divided among the number of allocated PRBs, i.e., Equal Power Allocation (EPA). The main simulation parameters are summarized in table 5.1.

```
1: for each TTI, cell, and PRB do
2:   Select one cellular UE using the PF scheduling policy
3:   for each D2D pair do
4:     Determine the band (DL or UL) to be used in the D2D link
5:     Set pair as active if selected band equals the comm. direction
6:   end for
7:   Randomly group an active D2D pair with the cellular UE
8:   Perform the link adaptation of selected UEs
9: end for
```

Figure 5.5: RRM simulation procedure.

Furthermore, the link adaptation procedure selects the Modulation and Coding Scheme (MCS) that yields the maximum SINR threshold [115], [153], and packets are error-free received. The main simulation parameters are summarized in table 5.1.

Table 5.1: Simulation parameters.

Parameter	Value	Reference
Number of eNBs ( $N_{\text{cell}}$ )	7 (with wrap-around)	
Cellular environment	Urban-microcell	[146]
Inter-Site distance	500 m	[146]
Minimal UE-eNB link distance	20 m	
eNB transmit power	38 dBm	[147]
UE transmit power	24 dBm	[147]
Cellular pathloss model [dB]	$34.5 + 38 \log_{10}(d)$ , $d$ in meter	[146]
Shadowing std. dev. ( $\sigma_{\text{sh}}$ )	10 dB	[147]
Fast fading model	3GPP SCM	[146]
Average UE speed	3 km/h	[147]
Antenna gain	6 dBi	[147]
Antenna configuration	SISO, omnidirectional	
Hotspot size (width $\times$ height)	$120 \times 50$ m	
Number of UEs per cell ( $N_{\text{UE}}$ )	16	
Percentage of hotspot UEs	50 %	
D2D pathloss model [dB]	$37 + 30 \log_{10}(d)$ , $d$ in meter	[151]
Central carrier frequency	1.90 GHz	[146]
System bandwidth ( $N_{\text{PRB}}$ )	5 MHz DL/UL (25 PRBs each)	[114]
Noise power at eNB/UE	-116.40 dBm/-112.40 dBm	
Link adaptation	LTE (15 MCSs)	[115], [153]
Required cell-edge SNR	-6.20 dB	[153]
Power allocation	EPA	
Scheduling policy	PF	[53]
Traffic model	Full buffer	
Effective TTI duration	1 ms	
Number of TTIs	1000	
Number of Monte Carlo runs	150	



## 5.4. Results and Discussion

The system performance results in terms of spectral efficiency are presented in table 5.2, considering only cellular communications and both communication modes without and with band selection technique for different band factors. In addition, the hotspot is moved from challenging to more favorable conditions for D2D communications to happen: “hotspot near eNB” and “hotspot at cell-edge”, respectively.

Table 5.2: Average system spectral efficiency (bps/Hz/cell).

	Cellular comm.		D2D comm.		Total		
	DL	UL	DL	UL	DL	UL	Agg.
Hotspot near eNB <sup>†</sup>							
No D2D comm.	3.88	4.80	–	–	3.88	4.80	8.68
No band sel.	1.67	3.03	1.65	1.48	3.32	4.51	7.83
$\alpha = 0.0$	3.34	3.29	0.37	1.40	3.71	4.69	8.40
$\alpha = 0.2$	2.35	4.15	1.17	0.96	3.52	5.11	8.63
$\alpha = 0.4$	1.86	4.61	1.51	0.49	3.37	5.10	8.47
$\alpha = 0.6$	1.74	4.71	1.59	0.26	3.33	4.97	8.30
$\alpha = 0.8$	1.70	4.75	1.62	0.15	3.32	4.90	8.22
$\alpha = 1.0$	1.69	4.77	1.63	0.09	3.32	4.86	8.18
Hotspot at cell-edge <sup>†</sup>							
No D2D comm.	2.60	3.54	–	–	2.60	3.54	6.14
No band sel.	1.48	2.56	2.85	2.10	4.33	4.66	8.99
$\alpha = 0.0$	2.58	2.56	0.03	2.10	2.61	4.66	7.27
$\alpha = 0.2$	2.56	2.65	0.51	2.06	3.07	4.71	7.78
$\alpha = 0.4$	2.24	2.87	1.40	1.87	3.64	4.74	8.38
$\alpha = 0.6$	1.96	3.06	1.96	1.62	3.92	4.68	8.60
$\alpha = 0.8$	1.79	3.20	2.28	1.36	4.07	4.56	8.63
$\alpha = 1.0$	1.69	3.29	2.47	1.14	4.16	4.43	8.59

<sup>†</sup> Hotspot near eNB or at cell-edge means, respectively, that the hotspot center is 50 and 200 m from eNB.

Results show that when band selection is not being used, the D2D-generated interference has a strong impact on cellular communications, yet its relevance is higher when hotspot is positioned near the eNB, with 2.21 bps/Hz/cell (or 57 %) and 1.77 bps/Hz/cell (or 37 %) of loss considering, respectively, DL and UL cellular spectral efficiency.

Nevertheless, the aforementioned advantages of D2D communications, clearly justify their use. For that, compare the total aggregated spectral efficiency achieved with and without D2D communications when hotspot location is at cell-edge; the achieved gain is 2.85 bps/Hz/cell (or 46 %). But, when hotspot is placed too much close to eNB, the higher co-channel interference drastically limits the whole system performance, reducing it 0.85 bps/Hz/cell (or 10 %).

While enabling band selection and based on the approach that was described in section 5.2, the best trade-off between system performance and interference mitigation is achieved for  $\alpha^* = 0.2$  when the hotspot is near eNB, and for  $\alpha^* = 0.8$  when the hotspot is at cell-edge. In both cases, the losses in cellular communications are reduced: from 57 to 39 % in DL and from

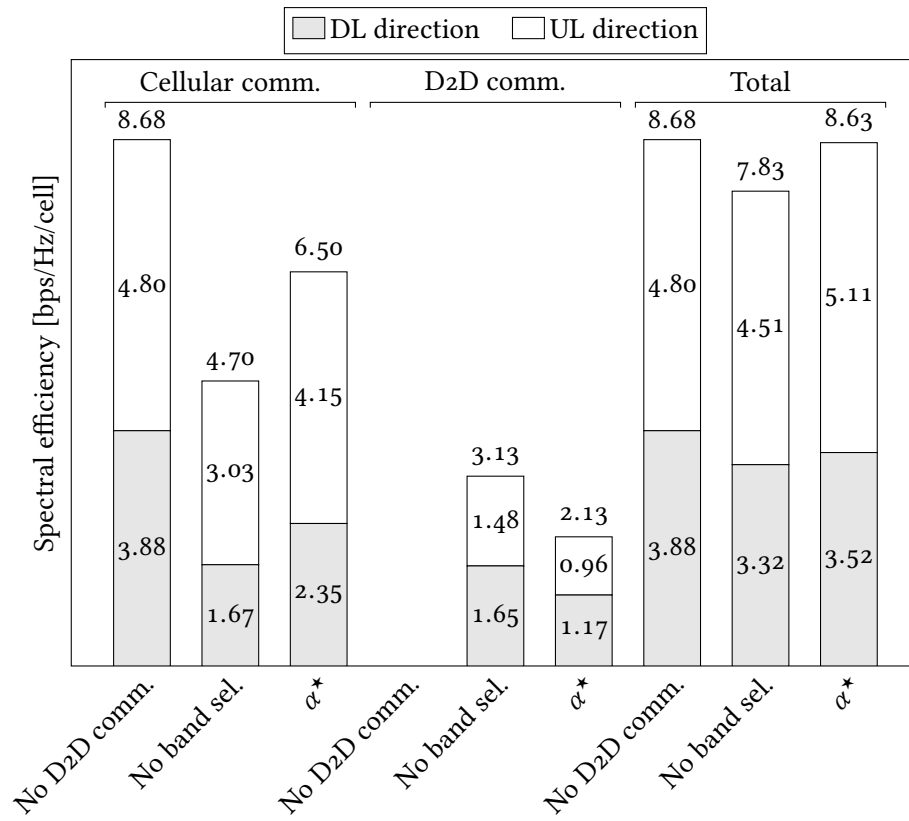

(a) Hotspot near eNB ( $\alpha^* = 0.2$ ).

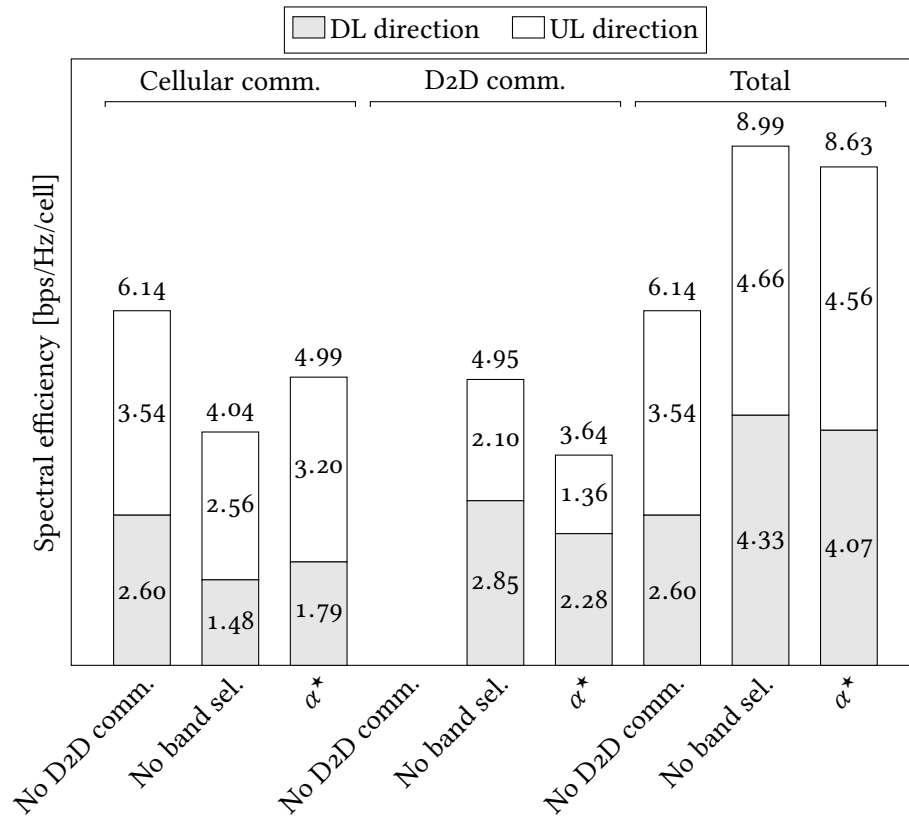

(b) Hotspot at cell-edge ( $\alpha^* = 0.8$ ).

Figure 5.6: Average system spectral efficiency.

37 to 14 % in UL for the former case; and from 43 to 31 % in DL and from 28 to 10 % in UL for the latter case. This result is better shown in figure 5.6, which visually complements table 5.2.

In general, band selection improves the gains of cellular communications and limits the gains of D2D communications both in DL and UL phases, regardless the hotspot position. This translates in an improvement of 10 % in the total aggregated spectral efficiency with hotspot near eNB and a tiny reduction of 4 % with hotspot at cell-edge.

In order to better understand how the band selection impacts on the whole system, let us look to the Cumulative Distribution Function (CDF) of SINR, which is presented in figure 5.7 for the hotspot near eNB, i.e., the most demanding conditions. Regardless the communication direction, the method improves the SINR curve of cellular communications making it tend to the one without D2D communications, compensating the slightly degrades in the SINR curve of D2D communications. When hotspot is at cell-edge (not shown here), the same conclusion applies as before. However, for that case the cellular interference on D2D communications, especially in DL, is reduced making the D2D gain higher.

Table 5.3: Average cellular outage probability (%).

	Hotspot near eNB		Hotspot at cell-edge	
	DL	UL	DL	UL
No D2D comm.	5.42	0.72	10.81	1.40
No band sel.	13.40	17.87	30.31	12.39
$\alpha^{\star\dagger}$	10.69	5.00	22.53	5.17

<sup>†</sup> For hotspot near eNB  $\alpha^{\star} = 0.2$  and at cell-edge  $\alpha^{\star} = 0.8$ .

The outage probability is a figure of merit for the system. It can be interpreted as the fraction of time in average that a UE stays out of service due to fading or, in other words, as the probability of UE's SINR falls below a given minimum, i.e.,  $P(\gamma \leq \Gamma_{min}) = \int_{-\infty}^{\Gamma_{min}} f_{\gamma}(t) dt = F_{\gamma}(\Gamma_{min})$ , where  $f_{\gamma}(\cdot)$  and  $F_{\gamma}(\cdot)$  are the Probability Density Function (PDF) and CDF of SINR, respectively. In LTE networks,  $\Gamma_{min}$  is the SINR threshold to ensure the lowest MCS. Thus, the outage probability may be measured as the number of UEs with zero throughput over the total UEs in the system.

As it can be observed in table 5.3 comparing the results without and with the use of band selection technique (rows four and five, respectively), the cellular outage probability is always reduced, which reveals the protection provided by the method against harmful interference. A better visual illustration of the same result can be seen in figure 5.8.

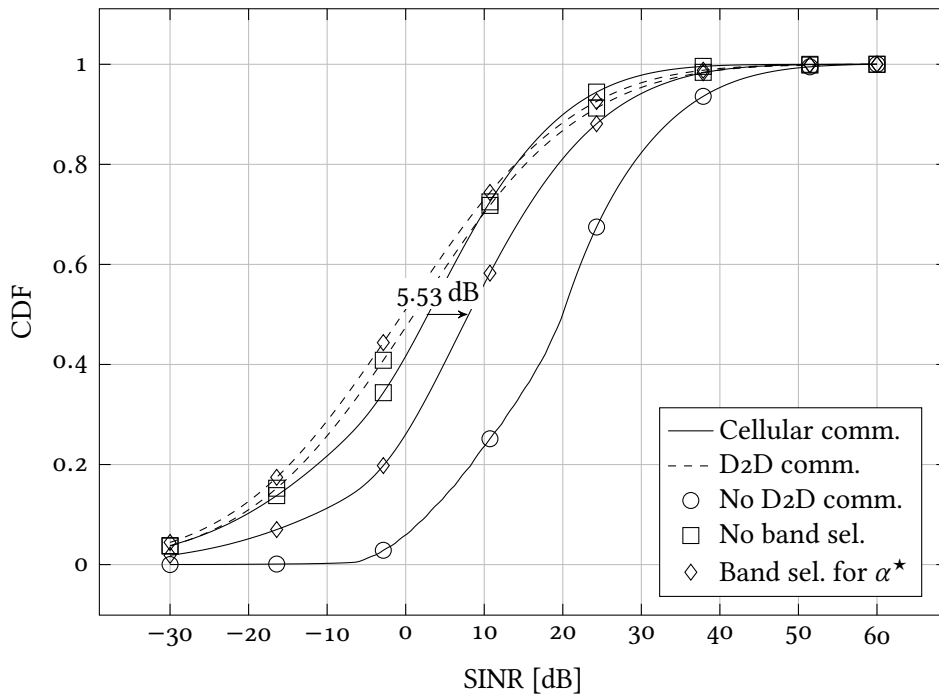

(a) DL direction.

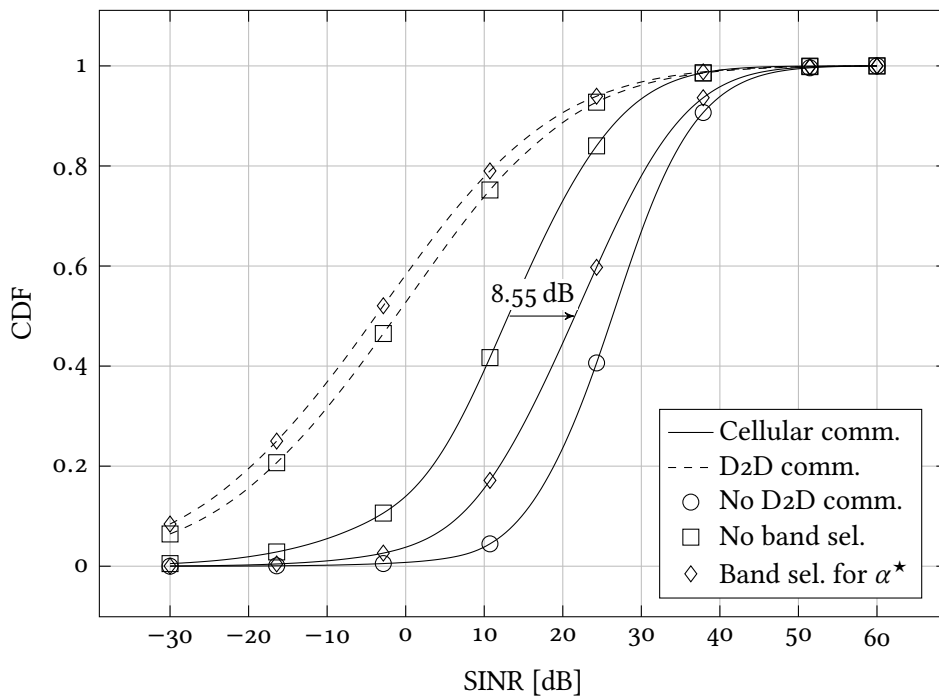

(b) UL direction.

Figure 5.7: SINR when hotspot is near eNB, where  $\alpha^* = 0.2$ : in the 50th percentile a gain of 5.53 and 8.55 dB is achieved for cellular communications in DL and UL directions, respectively.

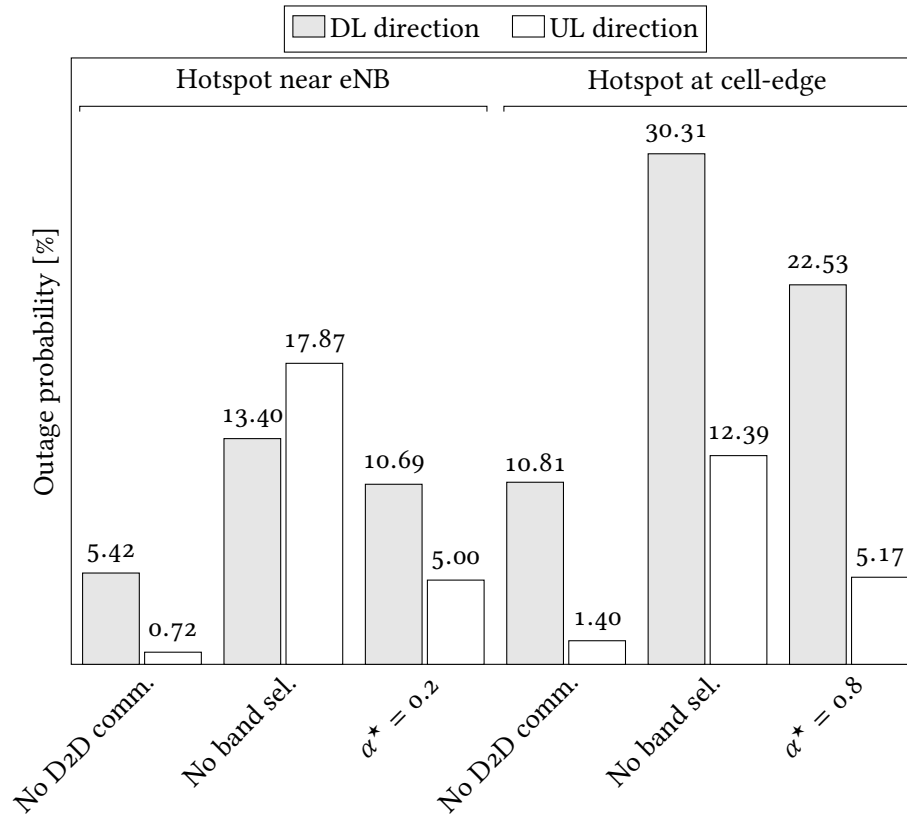

Figure 5.8: Average cellular outage probability.

## 5.5. Conclusion

In this chapter we investigated a novel interference mitigation technique that enables the coexistence of cellular and D2D communications in wireless systems that have in-band spectrum sharing (i.e., reuse factor less than one). Besides being simple formulated, the band selection technique has permitted gains in the DL and UL communication phases along with the protection of cellular network from excessive co-channel interference; which surely extends the recommendation of just reusing the UL band for D2D links [154].

The radio distance metric is prone to errors, especially if fast channel variations happen, since it represents in fact the link quality between the eNB and D2D transmitter rather than the real distance between them. In order to ensure a better location accuracy of D2D transmitter, reducing channel fluctuations, a time window filtering may be performed; and/or the radio distance metrics of its neighbors from discovery phase can be reported and combined in eNB; and/or use Global Positioning System (GPS).

Finally, future works may be related with:

- The combination of band selection and proper grouping techniques, e.g., minimum distance between D2D transmitter and receiver, instead of random grouping a cellular UE with a D2D pair to share the same radio resource [34] may provide further gains for the whole system;
- Also the use of Maximum Rate (MR) scheduler that always selects the cellular UE with the best instantaneous channel can provide better results, especially if the hotspot is located at cell-edge or for rural areas, which have a larger cell radius;

- In a daily use, the traffic generated in a network is asymmetric, i.e., the DL band is more used than the UL band. As such, the operator may limit the D2D-generated interference by selecting the less loaded band, especially in a time-based duplexing scheme, where the time window for DL can be bigger than the one for UL;
- Evaluate band selection algorithm in real cellular networks underlaid by D2D communications;
- An important step in the band selection algorithm is to correctly set the eNB threshold, which controls the amount of UEs that use either band. In this work a procedure has been proposed which establishes a trade-off between system performance and interference mitigation. Nevertheless, the best band factor may be based on any other goal, e.g., reduce the overall system outage probability;
- Also, optimization techniques can be employed to determine the best threshold.

## CHAPTER 6

---

### Thesis Conclusion

---

The thesis was devoted to the general topic of electromagnetic spectrum, especially contemporary spectrum reuse techniques: Television White Spaces (TVWS) and Device-to-Device (D2D) communications, which foresee in their basis a more flexible spectrum management, where primary (licensed or incumbent) and secondary (unlicensed or opportunistic) users coexist for an improved system capacity.

However, primary users, such as Television (TV) broadcasters or mobile operators, always feared (unpredictable) interference. Thence, they are mostly reluctant to a flexible spectrum use and do prefer the traditional allocation methods, where the interference from outside world is controlled or at least predictable. This thesis pretends to be a contribute to diminish that fear, making the spectrum a more democratic place, where all players/actors can afford it, being, therefore, a social catalyzer.

In the first part the theme of TVWS is explored. We start with a suitable Strengths, Weaknesses, Opportunities, and Threats (SWOT) analysis in chapter 2 in order to identify the main factors that sustain the reluctancy in their adoption. As a main conclusions, we state that:

- TVWS defenders shall focus on the promotion of a real-time secondary spectrum market, where through the correct implementation of policies for protection ratios in the spectrum broker and geo-location database, incumbents are protected against interference;
- Also important is to stimulate the development of innovative business models such that important TV stakeholders, like broadcasters, and mobile operators will make part of a valuable chain, thus encouraging regulators to develop supportive policies for the functioning of secondary spectrum markets.

To encourage the use of TVWS and promote a secondary market for the spectrum, we present a tecno-economic evaluation in chapter 3 for three different deployment scenarios: one with 2.60 GHz carrier frequency, a second with 700 MHz carrier frequency, and a third scenario with 2.60 GHz plus additional TVWS carrier. The first two are envisioned for a traditional market, while the latter is for the flexible secondary spectrum market. The principal conclusions are:

- While it is more profitable to deploy the network in a lower central carrier frequency (second scenario);
- The secondary market (third scenario) closely approaches the best result;
- On the other hand, the sensitivity analysis revealed that the network profitability is little sensitive to, e.g., the cost of spectrum, price of devices, or device subsidies, being moderately sensitive to clients base, and very sensitive to the Average Return Per User (ARPU);

- As such, the higher capacity due to the additional TVWS carrier, may allow mobile operators to increase the ARPU; and/or focus in attracting more clients by employing a strong marketing campaigns and/or promotions (increasing device subsidies and/or decreasing the price of devices), which would strongly impact in operator's profitability.

The second part of the thesis deals with D2D communications, especially the case when they underlay a cellular network. We start with the proposal for a novel neighbor discovery technique based on power vectors in chapter 4, which utilizes the already available network measurements, both for the single-cell and multi-cell scenarios. The relevant conclusions may be summarized in the following manner:

- Results show that with the network help, the time to detect neighbors per Mobile Station (MS) is significantly reduced, letting more time for the actual data transmission;
- The power of MS consumed during the discovery process is reduced because the main processing is done at the Base Station (BS), building the neighborhood relations, which for each MS is considered to be a small set. Thus, just before the session establishment, the MS needs to ensure that D2D communication can be established through the direct channel, e.g., by using a single pair of beacon/acknowledgement packets;
- With the proposed technique no new protocol implementation on signaling is required for the measurement process, because signal quality measurements are already available/exchanged in the network and are mandatory for it to operate. Also, BSs are connected through a dedicated link for data control, so no new link is required;
- The multi-cell cases, i.e., MSs that belong to different cells (served by different BSs) are able to discover each other, enabling the cross-cell border D2D communications.

Chapter 5 is the last technical chapter and it is devoted to the interference mitigation, where by employing the selection of transmission band (either Downlink (DL) or Uplink (UL)) for the D2D communication the interference caused in the cellular network is reduced, thus contributing for an enhanced overall system capacity. The main conclusions may be written as follows:

- Despite being a simple concept, in general, band selection improves the gains of cellular communications and limits the gains of D2D communications both in DL and UL phases, regardless the position within the cell where the D2D communications happen;
- Also, by using the band selection, the cellular outage probability is always reduced, which reveals the protection provided by the method against harmful interference.

## 6.1. Future Perspectives

Many works open the door for future improvements, presenting some possible research directions. This thesis is no exception. But what is future in the context of wireless systems? As stated in chapter 1, the future is the Fifth Generation (5G) of wireless systems, where the topics of spectrum sharing [10], Heterogeneous Networks (HetNets) [9], and Machine Type Communications (MTCs) [7], [8] are closely related with the contents of the thesis, see figure 6.1 (adapted from [4]).

As such, under the umbrella of 5G, future works/research directions, summing up what has already been written inside each chapter, may comprise the following:

- Chapter 2. SWOT Analysis for TVWS:



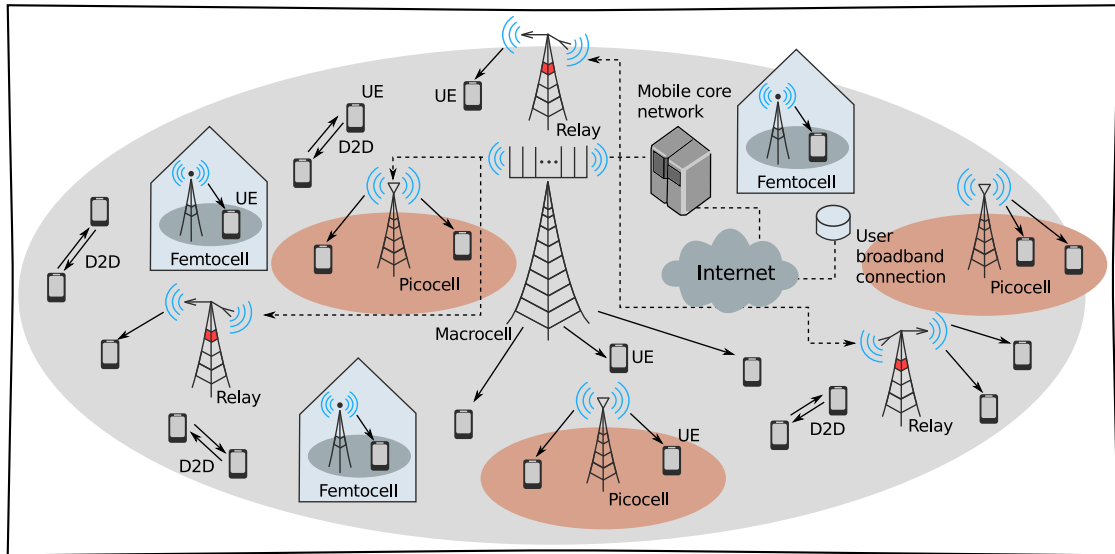

Figure 6.1: The 5G multi-tier network vision composed of macrocells, picocells, femtocells, relays, and D2D (MTC) links. Solid lines indicate wireless links, whereas dashed ones denote the backhaul connections.

- While always useful, the SWOT analysis is frequently not sufficient to explore the whole situation [98]. In other words, if we wish to analyze an industry and not just a product, other means shall be used, like, for instance, the Porter's Five Forces model [99], [100] or Analytic Hierarchy Process (AHP) [101], that can confirm its conclusions.
- Chapter 3. Techno-Economic Evaluation for TVWS:
  - The deployment of optimal strategies (with optimization problem formulation) to reduce the network costs while keeping the same coverage and capacity, and evaluate the use of TVWS in that context;
  - Also the use of Net Present Value (NPV) metric along with Monte Carlo runs [103], [120] to simulate uncertainties with a statistical characteristic (i.e., statistical distribution), is useful to model the risks associated with the flexible spectrum market and perform the sensitivity analysis.
- Chapter 4. Neighbor Discovery Using Power Vectors for D2D Communications:
  - Simulate the neighbor discovery for devices that belong to different cells (served by different BSs), which may happen close to cell boundaries;
  - Implement a timeout for the discover to happen (detection window) and count the false/missed detections;
  - Discover neighbors that do not fulfill the service request, which can be especially useful for social networks;
  - Evaluate the proposed power vectors method in real cellular networks underlaid by D2D communications.
- Chapter 5. Band Selection for D2D Communications:
  - The combination of band selection and proper grouping techniques, e.g., minimum distance between D2D transmitter and receiver, instead of random grouping

a cellular user with a D2D pair to share the same radio resource [34] may provide further gains for the whole system;

- Also the use of Maximum Rate (MR) scheduler that always selects the cellular device with the best instantaneous channel can provide better results, especially if the hotspot is located at cell-edge or for rural areas, which have a larger cell radius;
- In a daily use, the traffic generated in a network is asymmetric, i.e., the DL band is more used than the UL band. As such, the operator may limit the D2D-generated interference by selecting the less loaded band, especially in a time-based duplexing scheme, where the time window for DL can be bigger than the one for UL;
- Evaluate band selection algorithm in real cellular networks underlaid by D2D communications;
- Use other criteria to set the threshold in each cell, which controls the amount of devices that use either band. The best band factor may be based on, e.g., reducing the overall system outage probability;
- Also, optimization techniques can be used to determine the best threshold.

---

## References

---

- [1] Cisco, “Cisco visual networking index: Global mobile data traffic forecast update, 2014–2019”, White paper, Feb. 2015, pp. 1–42. [Online]. Available: [http://www.cisco.com/c/en/us/solutions/collateral/service-provider/visual-networking-index-vni/white\\_paper\\_c11-520862.pdf](http://www.cisco.com/c/en/us/solutions/collateral/service-provider/visual-networking-index-vni/white_paper_c11-520862.pdf) (visited on 10/2015).
- [2] Ericsson, *RWS-120003 LTE release 12 and beyond*, 3GPP Radio Access Network Workshop on Release 12 and Onwards, Ljubljana, Slovenia, Jun. 2012.
- [3] J. G. Andrews, S. Buzzi, W. Choi, S. V. Hanly, A. Lozano, A. C. K. Soong, and J. C. Zhang, “What will 5G be?”, *IEEE Journal on Selected Areas in Communications*, vol. 32, no. 6, pp. 1065–1082, Jun. 2014, ISSN: 0733-8716. DOI: 10.1109/JSAC.2014.2328098.
- [4] E. Hossain, M. Rasti, H. Tabassum, and A. Abdelnasser, “Evolution toward 5G multi-tier cellular wireless networks: An interference management perspective”, *IEEE Wireless Communications*, vol. 21, no. 3, pp. 118–127, Jun. 2014, ISSN: 1536-1284. DOI: 10.1109/MWC.2014.6845056.
- [5] E. G. Larsson, F. Tufvesson, O. Edfors, and T. L. Marzetta, “Massive MIMO for next generation wireless systems”, *IEEE Communications Magazine*, vol. 52, no. 2, pp. 186–195, Feb. 2014, ISSN: 0163-6804. DOI: 10.1109/MCOM.2014.6736761.
- [6] S. Rangan, T. S. Rappaport, and E. Erkip, “Millimeter wave cellular wireless networks: Potentials and challenges”, *Proceedings of the IEEE*, vol. 102, no. 3, pp. 366–385, Feb. 2014, ISSN: 0018-9219. DOI: 10.1109/JPROC.2014.2299397.
- [7] S. Mumtaz, K. M. S. Huq, and J. Rodriguez, “Direct mobile-to-mobile communication: Paradigm for 5G”, *IEEE Wireless Communications*, vol. 21, no. 5, pp. 14–23, Oct. 2014, ISSN: 1536-1284. DOI: 10.1109/MWC.2014.6940429.
- [8] L. Wei, R. Q. Hu, Y. Qian, and G. Wu, “Enable device-to-device communications underlying cellular networks: Challenges and research aspects”, *IEEE Communications Magazine*, vol. 52, no. 6, pp. 90–96, Jun. 2014, ISSN: 0163-6804. DOI: 10.1109/MCOM.2014.6829950.
- [9] J. G. Andrews, “Seven ways that hetnets are a cellular paradigm shift”, *IEEE Communications Magazine*, vol. 51, no. 3, pp. 136–144, Mar. 2013, ISSN: 0163-6804. DOI: 10.1109/MCOM.2013.6476878.
- [10] J. Mitola III *et al.*, “Accelerating 5G QoE via public-private spectrum sharing”, *IEEE Communications Magazine*, vol. 52, no. 5, pp. 77–85, May 2014, ISSN: 0163-6804. DOI: 10.1109/MCOM.2014.6815896.
- [11] T. M. Taher, R. B. Bacchus, K. J. Zdunek, and D. A. Roberson, “Long-term spectral occupancy findings in chicago”, in *2011 IEEE Symposium on Dynamic Spectrum Access Networks (DySPAN)*, May 2011, pp. 100–107. DOI: 10.1109/DYSPAN.2011.5936195.

- [12] A. Palaios, J. Riihijärvi, O. Holland, and P. Mähönen, “A week in London: Spectrum usage in metropolitan London”, in *IEEE 24th Annual International Symposium on Personal, Indoor, and Mobile Radio Communications (PIMRC)*, Sep. 2013, pp. 2532–2537. DOI: 10.1109/PIMRC.2013.6666571.
- [13] M. Prazy, “The profitability analysis of the multi-band spectrum broker”, in *IEEE 24th Annual International Symposium on Personal, Indoor, and Mobile Radio Communications (PIMRC)*, Sep. 2013, pp. 3454–3458. DOI: 10.1109/PIMRC.2013.6666742.
- [14] OFCOM, “Digital dividend review: Geographic interleaved awards 470–550 MHz and 630–790 MHz”, Consultation, Jun. 2008.
- [15] E. C. C. (ECC), “Technical considerations regarding harmonisation options for the digital dividend”, Compatibility issues between “cellular / low power transmitter” networks and “larger coverage / high power / tower” type of networks, European Conference of Postal and Telecommunications Administrations (CEPT), CEPT Report 21, Mar. 2007. [Online]. Available: [www.erodocdb.dk/docs/doc98/official/pdf/CEPTREP021.pdf](http://www.erodocdb.dk/docs/doc98/official/pdf/CEPTREP021.pdf) (visited on 10/2015).
- [16] —, “Technical considerations regarding harmonisation options for the digital dividend”, A preliminary assessment of the feasibility of fitting new/future applications/services into non-harmonised spectrum of the digital dividend (namely the so-called “white spaces” between allotments), European Conference of Postal and Telecommunications Administrations (CEPT), CEPT Report 24, Jun. 2008. [Online]. Available: <http://www.erodocdb.dk/docs/doc98/official/pdf/CEPTRep024.pdf> (visited on 10/2015).
- [17] COGEU, “European TV white spaces analysis and COGEU use-cases”, Deliverable 2.1, Mar. 2010, Version 1.0. [Online]. Available: <http://www.ict-cogeu.eu/deliverables.html> (visited on 10/2015).
- [18] OFCOM, “Implementing TV white spaces”, Statement, Feb. 2015. [Online]. Available: <http://stakeholders.ofcom.org.uk/binaries/consultations/white-space-coexistence/statement/tvws-statement.pdf> (visited on 10/2015).
- [19] FCC, “In the matter of unlicensed operation in the TV broadcast bands: Et docket no. 04-186”, Washington D.C., Order DA 11-131, Jan. 2011.
- [20] A. Yang, *Overview of FCC’s new rules for TV white space devices and database updates*, ITU-R SG 1/WP 1B Workshop: Spectrum Management Issues on the Use of White Spaces By Cognitive Radio Systems, Geneva, Switzerland, Jan. 2014. [Online]. Available: <http://www.itu.int/en/ITU-R/study-groups/workshops/RWP1B-SMWSCRS-14/Presentations/USA%20-%20Overview%20of%20FCC%E2%80%99s%20New%20Rules%20for%20TV%20White%20Space%20Devices%20and%20database%20updates.pdf> (visited on 10/2015).
- [21] FCC, *Et docket no. 04-186*, Washington D.C., Sep. 2014. [Online]. Available: [https://apps.fcc.gov/edocs\\_public/attachmatch/DA-14-1309A1.pdf](https://apps.fcc.gov/edocs_public/attachmatch/DA-14-1309A1.pdf) (visited on 10/2015).
- [22] C. A. A. Afonso, “New cognitive radio technologies, white spaces and the digital dividend in the brazilian context”, in *TV White Spaces: A Pragmatic Approach*, E. Pietrosemoli and M. Zennaro, Eds., 1st ed., The Abdus Salam International Centre for Theoretical Physics, Dec. 2013, pp. 43–50, ISBN: 978-9295003-50-7.

- [23] E. Obregon, K. W. Sung, and J. Zander, "On the sharing opportunities for ultra-dense networks in the radar bands", in *2014 IEEE International Symposium on Dynamic Spectrum Access Networks (DySPAN)*, Apr. 2014, pp. 215–223. DOI: 10.1109/DySPAN.2014.6817798.
- [24] H. Bogucka, M. Parzy, P. Marques, J. W. Mwangoka, and T. Forde, "Secondary spectrum trading in TV white spaces", *IEEE Communications Magazine*, vol. 50, no. 11, pp. 121–129, Nov. 2012. DOI: 10.1109/MCOM.2012.6353691.
- [25] "Terrestrial trunked radio (TETRA); voice plus data (V+D); part 2: Air interface (AI)", European Telecommunications Standards Institute (ETSI), ETSI TS 100 392-2, Oct. 2011, Version 3.5.1. [Online]. Available: [http://www.etsi.org/deliver/etsi\\_ts/100300\\_100399/10039202/03.05.01\\_60/ts\\_10039202v030501p.pdf](http://www.etsi.org/deliver/etsi_ts/100300_100399/10039202/03.05.01_60/ts_10039202v030501p.pdf) (visited on 08/2012).
- [26] G. Fodor, E. Dahlman, G. Mildh, S. Parkvall, N. Reider, G. Miklós, and Z. Turányi, "Design aspects of network assisted device-to-device communications", *IEEE Communications Magazine*, vol. 50, no. 3, pp. 170–176, Mar. 2012, ISSN: 0163-6804. DOI: 10.1109/MCOM.2012.6163598.
- [27] K. Doppler, M. Rinne, C. Wijting, C. B. Ribeiro, and K. Hugl, "Device-to-device communication as an underlay to LTE-advanced", *IEEE Communications Magazine*, vol. 47, no. 12, pp. 42–49, Dec. 2009, ISSN: 0163-6804. DOI: 10.1109/MCOM.2009.5350367.
- [28] M. S. Corson, R. Laroia, J. Li, V. Park, T. Richardson, and G. Tsirtsis, "Toward proximity-aware internetworking", *IEEE Wireless Communications*, vol. 17, no. 6, pp. 26–33, Dec. 2010, ISSN: 1536-1284. DOI: 10.1109/MWC.2010.5675775.
- [29] L. Lei, Z. Zhong, C. Lin, and X. Shen, "Operator controlled device-to-device communications in LTE-advanced networks", *IEEE Wireless Communications*, vol. 19, no. 3, pp. 96–104, Jun. 2012, ISSN: 1536-1284. DOI: 10.1109/MWC.2012.6231164.
- [30] J. M. B. da Silva Jr., G. Fodor, and T. F. Maciel, "Performance analysis of network-assisted two-hop D2D communications", in *IEEE Global Communications Conference Workshops (GC'14 Wkshps)*, Dec. 2014, pp. 1050–1056. DOI: 10.1109/GLOCOMW.2014.7063572.
- [31] 3GPP, "Feasibility study for proximity services (ProSe)", 3rd Generation Partnership Project (3GPP), TR 22.803, Jun. 2013. [Online]. Available: <http://www.3gpp.org/ftp/specs/html-info/22803.htm> (visited on 06/2014).
- [32] P. Phunchongharn, E. Hossain, and D. I. Kim, "Resource allocation for device-to-device communications underlaying LTE-advanced network", *IEEE Communications Magazine*, vol. 20, no. 4, pp. 91–100, Aug. 2013, ISSN: 1536-1284. DOI: 10.1109/MWC.2013.6590055.
- [33] G. Fodor, D. D. Penda, M. Belleschi, and M. Johansson, "A comparative study of power control approaches for device-to-device communications", in *IEEE International Conference on Communications (ICC'13)*, Budapest, Hungary: IEEE, Jun. 2013.
- [34] J. M. B. da Silva Jr., T. F. Maciel, R. L. Batista, C. F. M. e Silva, and F. R. P. Cavalcanti, "UE grouping and mode selection for D2D communications underlaying a multicellular wireless system", in *IEEE WCNC 2014 - Workshop on Device-to-Device and Public Safety Communications (WCNC'14 - WDPC Workshop)*, Istanbul, Turkey, Apr. 2014, pp. 230–235.

- [35] K. Doppler, C.-H. Yu, C. B. Ribeiro, and P. Jänis, “Mode selection for device-to-device communication underlying an LTE-advanced network”, in *IEEE Wireless Communications and Networking Conference (WCNC’10)*, Apr. 2010, pp. 1–6. DOI: 10.1109/WCNC.2010.5506248.
- [36] P. Jänis, V. Koivunen, C. B. Ribeiro, K. Doppler, and K. Hugl, “Interference-avoiding MIMO schemes for device-to-device radio underlying cellular networks”, in *IEEE 20th Personal, Indoor and Mobile Radio Communications Symposium (PIMRC’09)*, Sep. 2009, pp. 2385–2389, ISBN: 978-1-4244-5122-7. DOI: 10.1109/PIMRC.2009.5450284.
- [37] C.-H. Yu, O. Tirkkonen, K. Doppler, and C. B. Ribeiro, “Power optimization of device-to-device communication underlying cellular communication”, in *IEEE International Conference on Communications (ICC’09)*, Jun. 2009, pp. 1–5. DOI: 10.1109/ICC.2009.5199353.
- [38] Y. V. L. de Melo, R. L. Batista, C. F. M. e Silva, T. F. Maciel, J. M. B. da Silva Jr., and F. R. P. Cavalcanti, “Power control schemes for energy efficiency of cellular and device-and-device communications”, in *IEEE Wireless Communications and Networking Conference (WCNC’15)*, Mar. 2015, pp. 1690–1694. DOI: 10.1109/WCNC.2015.7127722.
- [39] ———, “Uplink power control with variable target SINR for D2D communications underlying cellular networks”, in *IEEE 81st Vehicular Technology Conference (VTC 2015-Spring)*, May 2015, pp. 1–5. DOI: 10.1109/VTCSpring.2015.7146150.
- [40] R. Tanbourgi, H. Jäkel, and F. K. Jondral, “Cooperative interference cancellation using device-to-device communications”, *IEEE Communications Magazine*, vol. 52, no. 6, pp. 118–124, Jun. 2014, ISSN: 0163-6804. DOI: 10.1109/MCOM.2014.6829953.
- [41] S. Xu and K. S. Kwak, “Effective interference coordination for D2D underlying LTE networks”, in *IEEE 79th Vehicular Technology Conference (VTC 2014-Spring)*, May 2014, pp. 1–5. DOI: 10.1109/VTCSpring.2014.7022897.
- [42] G. Fodor, A. Pradini, and A. Gattami, “On applying network coding in network assisted device-to-device communications”, in *Proceedings of 20th European Wireless (EW’14)*, Barcelona, Spain, May 2014.
- [43] C. F. M. Silva, J. M. B. Silva Jr., and T. F. Maciel, “Radio resource management for device-to-device communications in long term evolution networks”, in *Resource Allocation and MIMO for 4G and Beyond*, F. R. P. Cavalcanti, Ed., New York, USA: Springer Science+Business Media, 2014, pp. 105–156, ISBN: 978-1-4614-8056-3. DOI: 10.1007/978-1-4614-8057-0\_3.
- [44] A. Asadi, Q. Wang, and V. Mancuso, “A survey on device-to-device communication in cellular networks”, *IEEE Communications Surveys and Tutorials*, vol. 16, no. 4, pp. 1801–1819, Apr. 2014, ISSN: 1553-877X. DOI: 10.1109/COMST.2014.2319555.
- [45] C. F. Silva, H. Alves, and Á. Gomes, “Extension of LTE operational mode over TV white spaces”, in *Future Network and Mobile Summit 2011 Conference Proceedings*, Warsaw, Poland, Jun. 2011, pp. 1–13. [Online]. Available: [http://www.ict-cogeu.eu/pdf/publications/Y2/FUNEMS\\_2011\\_COGEU\\_paper\\_n2.pdf](http://www.ict-cogeu.eu/pdf/publications/Y2/FUNEMS_2011_COGEU_paper_n2.pdf) (visited on 10/2015).
- [46] C. Dosch, J. Kubasik, and C. F. M. Silva, “TVWS policies to enable efficient spectrum sharing”, in *22nd European Regional Conference of the International Telecommunications Society (ITS 2011)*, Budapest, Hungary, Sep. 2011, pp. 1–26. [Online]. Available: <http://hdl.handle.net/10419/52145> (visited on 10/2015).

- [47] C. F. M. Silva, F. R. P. Cavalcanti, and Á. Gomes, "SWOT analysis for TV white spaces", *Transactions on Emerging Telecommunications Technologies*, vol. 26, no. 6, pp. 957–974, Jun. 2015, Published online: Dec. 2013, ISSN: 2161-3915. DOI: 10.1002/ett.2770.
- [48] C. F. M. e Silva and R. L. Batista, "Methods, nodes and user equipments for finding neighboring user equipments with which a first user equipment may be able to communicate directly", P43774WO, Jul. 2014.
- [49] C. F. M. e Silva, T. F. Maciel, R. L. Batista, L. Elias, A. Robson, and F. R. P. Cavalcanti, "Network-assisted neighbor discovery based on power vectors for D2D communications", in *IEEE 81st Vehicular Technology Conference (VTC 2015-Spring)*, May 2015, pp. 1–5, ISBN: 978-1-4799-8088-8.
- [50] C. F. M. e Silva, R. L. Batista, J. M. B. Silva Jr., T. F. Maciel, and F. R. P. Cavalcanti, "Interference mitigation using band selection for network-assisted D2D communications", in *IEEE 81st Vehicular Technology Conference (VTC 2015-Spring)*, May 2015, pp. 1–5, ISBN: 978-1-4799-8088-8.
- [51] C. F. M. e Silva and G. Fodor, "Method and system of a wireless communication network for detecting neighbouring UEs, of a first UE", P47887WO, Nov. 2015.
- [52] R. L. Batista, C. F. M. e Silva, J. M. B. da Silva Jr., T. F. Maciel, and F. R. P. Cavalcanti, "Impact of device-to-device communications on cellular communications in a multi-cell scenario", in *XXXI Telecommunications Brazilian Symposium (SBrT2013)*, Fortaleza, Brazil, Sep. 2013. DOI: 10.14209/sbrt.2013.241.
- [53] R. L. Batista, C. F. M. e Silva, J. M. B. da Silva Jr., T. F. Maciel, and F. R. P. Cavalcanti, "What happens with a proportional fair cellular scheduling when D2D communications underlay a cellular network?", in *IEEE WCNC 2014 - Workshop on Device-to-Device and Public Safety Communications (WCNC'14 - WDPC Workshop)*, Istanbul, Turkey, Apr. 2014, pp. 260–265.
- [54] R. L. Batista, C. F. M. e Silva, T. F. Maciel, and F. R. P. Cavalcanti, "Method and radio network node for scheduling of wireless devices in a cellular network", P42550WO, Apr. 2014.
- [55] R. L. Batista, C. F. M. e Silva, J. M. B. da Silva Jr., T. F. Maciel, and F. R. P. Cavalcanti, "Power prediction prior to scheduling combined with equal power allocation for the OFDMA UL", in *Proceedings of 20th European Wireless (EW'14)*, Barcelona, Spain, May 2014.
- [56] R. L. Batista, C. F. M. e Silva, T. F. Maciel, J. M. B. da Silva Jr., and F. R. P. Cavalcanti, "Joint opportunistic scheduling of cellular and D2D communications", *IEEE Transactions on Vehicular Technology*, Submitted, ISSN: 0018-9545.
- [57] J. M. B. da Silva Jr., T. F. Maciel, C. F. M. e Silva, R. L. Batista, and Y. V. L. de Melo, "Spatial user grouping for D2D communications underlying a multi-cell wireless system", *EURASIP Journal on Wireless Communications and Networking*, Submitted, ISSN: 1687-1499.
- [58] Y. V. L. de Melo, R. L. Batista, T. F. Maciel, C. F. M. e Silva, J. M. B. da Silva Jr., and F. R. P. Cavalcanti, "Power control with variable target SINR for D2D communications underlying cellular networks", in *Proceedings of 20th European Wireless (EW'14)*, Barcelona, Spain, May 2014.

- [59] A. R. F. de Oliveira, L. Elias, C. F. M. e Silva, T. F. Maciel e F. R. P. Cavalcanti, «Descoberta de vizinhos baseada em vetores de potência para comunicações D2D [Neighbor discovery based on power vectors for D2D communications]», em *XXXIII Telecommunications Brazilian Symposium (SBrT2015)*, Original document in Portuguese, set. de 2015, pp. 1–2.
- [60] ETSI, “Reconfigurable radio systems (RRS); use cases for operation in white space frequency bands”, TR 102 907, Oct. 2011, Version 1.1.1.
- [61] J. Mitola III and G. Q. Maguire Jr., “Cognitive radio: Making software radios more personal”, *IEEE Personal Communications*, vol. 6, no. 4, pp. 13–18, Aug. 1999. DOI: 10.1109/98.788210.
- [62] J. Mitola III, “Cognitive radio: An integrated agent architecture for software defined radio”, PhD thesis, Royal Institute of Technology (KTH), Stockholm, Sweden, May 2000.
- [63] S. Mangold, L. Berlemann, and S. Nandagopalan, “Spectrum sharing with value-orientation for cognitive radio”, *European Transactions on Telecommunications*, vol. 17, no. 3, pp. 383–394, May 2006. DOI: 10.1002/ett.1120.
- [64] COGEU, “Initial architecture for TVWS spectrum sharing systems”, Deliverable 3.2, Jan. 2011, Version 3.0. [Online]. Available: <http://www.ict-cogeu.eu/deliverables.html> (visited on 10/2015).
- [65] L. Bicho e S. Baptista, *Modelo de porter e análise SWOT: Estratégias de negócio [porter’s model and SWOT analysis: Business strategies]*, Instituto Politécnico de Coimbra: Departamento de Engenharia Civil, Original document in Portuguese, dez. de 2006.
- [66] A. Chapman, *SWOT analysis: SWOT analysis method and examples, with free SWOT template*, 2005–2011. [Online]. Available: <http://www.businessballs.com/swotanalysisfreetemplate.htm> (visited on 07/2011).
- [67] J. M. Chapin and W. H. Lehr, “The path to market success for dynamic spectrum access technology”, *IEEE Communications Magazine*, vol. 45, no. 5, pp. 96–103, May 2007. DOI: 10.1109/MCOM.2007.358855.
- [68] E. C. Committee, “Technical and operational requirements for the possible operation of cognitive radio systems in the ‘white spaces’ of the frequency band 470–790 MHz”, Cardiff, ECC Report 159, Jan. 2011. [Online]. Available: <http://www.erodocdb.dk/docs/doc98/official/Pdf/ECCRep159.pdf> (visited on 12/2011).
- [69] M. Nekovee, “A survey of cognitive radio access to TV white spaces”, *International Journal of Digital Multimedia Broadcasting*, vol. 2010, pp. 1–12, 2010.
- [70] FCC, “In the matter of unlicensed operation in the TV broadcast bands: Et docket no. 04-186”, Washington D.C., Second Memorandum Opinion and Order FCC 10-174, Sep. 2010.
- [71] COGEU, “Policies to enable efficient spectrum sharing over TVWS at European level”, Deliverable 2.2, Mar. 2011, Version 1.0. [Online]. Available: <http://www.ict-cogeu.eu/deliverables.html> (visited on 10/2015).
- [72] M. Parzy and H. Bogucka, “Non-identical objects auction for spectrum sharing in TV white spaces—the perspective of service providers as secondary users”, in *2011 IEEE Symposium on Dynamic Spectrum Access Networks (DySPAN)*, May 2011, pp. 389–398. DOI: 10.1109/DYSPAN.2011.5936228.



- [73] ANACOM, «Projecto de decisão sobre a limitação do número de direitos de utilização de frequências nas faixas dos 450 MHz, 800 MHz, 900 MHz, 1800 MHz, 2.10 GHz e 2.60 GHz e definição do respectivo procedimento de atribuição [Decision project about the limitation in the number of utilization rights for the frequencies in bands of 450 MHz, 800 MHz, 900 MHz, 1800 MHz, 2.10 GHz and 2.60 GHz and definition of respective attribution procedure]», Deliberação 17.03.2011, mar. de 2011, Original document in Portuguese.
- [74] —, «Projecto de regulamento do leilão para a atribuição de direitos de utilização de frequências nas faixas dos 450 MHz, 800 MHz, 900 MHz, 1800 MHz, 2.10 GHz e 2.60 GHz [Regulation project for the attribution of usage rights of frequencies in the bands of 450 MHz, 800 MHz, 900 MHz, 1800 MHz, 2.10 GHz and 2.60 GHz]», Regulamento, mar. de 2011, Original document in Portuguese.
- [75] M. Cave, *Anti-competitive behaviour in spectrum markets*, Apr. 2009.
- [76] ERG-RSPG, “ERG-RSPG report on radio spectrum competition issues”, ERG (09) 22, Jun. 2009.
- [77] R. Murty, R. Chandra, T. Moscibroda, and P. Bahl, “Senseless: A database-driven white spaces network”, in *2011 IEEE Symposium on Dynamic Spectrum Access Networks (DySPAN)*, May 2011, pp. 10–21. DOI: 10.1109/DYSPAN.2011.5936197.
- [78] D. Makris, G. Gardikis, and A. Kourtis, “Quantifying TV white space capacity: A geolocation-based approach”, *IEEE Communications Magazine*, vol. 50, no. 9, pp. 145–152, Sep. 2012. DOI: 10.1109/MCOM.2012.6295725.
- [79] E. C. C. (ECC), “Technical considerations regarding harmonisation options for the digital dividend in the European Union”, Guideline on cross border coordination issues between mobile services in one country and broadcasting services in another country, European Conference of Postal and Telecommunications Administrations (CEPT), CEPT Report 29, Jun. 2009. [Online]. Available: [www.erodocdb.dk/docs/doc98/official/pdf/CEPTREP029.pdf](http://www.erodocdb.dk/docs/doc98/official/pdf/CEPTREP029.pdf) (visited on 10/2015).
- [80] GSMA, *Digital dividend for mobile: Bringing broadband to all*, Brochure, 2009. [Online]. Available: <http://www.gsma.com/spectrum/wp-content/uploads/2012/07/Spectrum-Digital-dividend-for-mobile-English.pdf> (visited on 10/2015).
- [81] COGEU, “Final architecture for TVWS spectrum sharing systems”, Deliverable 3.3, Sep. 2011, Version 1.0. [Online]. Available: <http://www.ict-cogeu.eu/deliverables.html> (visited on 10/2015).
- [82] E. Parliament and Council, *Multi-annual radio spectrum policy programme*, Feb. 2012.
- [83] OFCOM, “Simplifying spectrum trading—spectrum leasing and other market enhancements”, Final statement, Jun. 2011.
- [84] M. Baker, *LTE-advanced physical layer*, IMT-Advanced Evaluation Workshop, Beijing, Dec. 2009.
- [85] A. Solheim, *Choosing the backhaul for LTE*, Mar. 2009. [Online]. Available: <http://www.mobilitytechzone.com/topics/4g-wirelessevolution/articles/52237-choosing-backhaul-lte.htm> (visited on 08/2011).
- [86] Cisco, “Cisco visual networking index: Global mobile data traffic forecast update, 2011–2016”, White paper, Feb. 2012, pp. 1–29. [Online]. Available: [http://www.efocus.sk/images/uploads/cisco\\_data\\_traffic\\_2016.pdf](http://www.efocus.sk/images/uploads/cisco_data_traffic_2016.pdf) (visited on 10/2015).

- [87] M. Nekovee, “Current trends in regulation of secondary access to TV white spaces using cognitive radio”, in *IEEE GLOBECOM 2011*, Accepted, Houston, Dec. 2011.
- [88] S. Y. Tan, R. Karimi, A. Gowans, and D. Donachie, “Draft regulatory requirements for white space devices in the UHF TV band”, OFCOM, Discussion document, Feb. 2012, Draft.
- [89] G. Yuan, X. Zhang, W. Wang, and Y. Yang, “Carrier aggregation for LTE-advanced mobile communication systems”, *IEEE Communications Magazine*, vol. 48, no. 2, pp. 88–93, Feb. 2010.
- [90] M. Baker, “From LTE-advanced to the future”, *IEEE Communications Magazine*, vol. 50, no. 2, pp. 116–120, Feb. 2012. DOI: 10.1109/MCOM.2012.6146490.
- [91] ITU, *Resolution ITU-R 58, Studies on the implementation and use of cognitive radio systems*, Jan. 2012.
- [92] OFCOM, *Ofcom progresses plans for new wireless technology*, Nov. 2010. [Online]. Available: <http://media.ofcom.org.uk/2010/11/09/ofcom-progresses-plans-for-new-wireless-technology/> (visited on 08/2011).
- [93] E. Commission, “Promoting the shared use of radio spectrum resources in the internal market”, Communication from the Commission to the European Parliament, the Council, the European Economic and Social Committee and the Committee of Regions COM(2012) 478 final, Sep. 2012. [Online]. Available: <http://eur-lex.europa.eu/LexUriServ/LexUriServ.do?uri=COM:2012:0478:FIN:EN:PDF>.
- [94] OFCOM, “Implementing geolocation”, Consultation, Dec. 2011.
- [95] ITU and W. Bank, *Dispute resolution in the telecommunications sector: Current practices and future directions*, Oct. 2004.
- [96] H. Assef, *The meaning of reconciliation*, European Centre for Conflict Prevention, May 1999. [Online]. Available: [http://www.gppac.net/documents/pbp/part1/2\\_reconc.htm](http://www.gppac.net/documents/pbp/part1/2_reconc.htm) (visited on 08/2011).
- [97] P. Xavier, *Licensing of third generation (3G) mobile: Briefing paper*, ITU-International Telecommunication Union: 3G Licensing Workshop, Sep. 2001.
- [98] N. Pahl and A. Richter, *SWOT Analysis—Idea, Methodology And A Practical Approach*. GRIN Academic Publishing, 2007, ISBN: 978-3-640-30303-8.
- [99] H. de Swaan Arons and P. Waalewijn, *A knowledge base representing Porter’s five forces model*, Rotterdam: Erasmus University, 1999.
- [100] M. H. Evans, *Course 12: Competitive intelligence (part 2 of 2)*, Excellence in Financial Management, 2004.
- [101] T. L. Saaty, *Decision Making for Leaders: The Analytic Hierarchy Process for Decisions in a Complex World*, 3rd ed. Pittsburgh, USA: RWS Publications, 2012, ISBN: 0-9620317-8-X.
- [102] S. Bichler and J. Nitzan, *Systemic fear, modern finance and the future of capitalism*, Jerusalem and Montreal, Jul. 2010. [Online]. Available: [http://bnarchives.yorku.ca/289/03/20100700\\_bn\\_systemic\\_fear\\_modern\\_finance\\_future\\_of\\_capitalism.pdf](http://bnarchives.yorku.ca/289/03/20100700_bn_systemic_fear_modern_finance_future_of_capitalism.pdf) (visited on 10/2015).
- [103] S. C. Savvides, “Risk analysis in investment appraisal”, *Project Appraisal*, vol. 9, no. 1, pp. 3–18, Mar. 1994. [Online]. Available: [https://mpr.ub.uni-muenchen.de/10035/1/MPRA\\_paper\\_10035.pdf](https://mpr.ub.uni-muenchen.de/10035/1/MPRA_paper_10035.pdf) (visited on 10/2015).

- [104] V. Maroyi, “Capital budgeting practices: A South African perspective”, Master’s thesis, Wageningen University, Wageningen, Netherlands, Aug. 2011.
- [105] COGEU, “Spectrum-aware routing, transport protocols and negotiation protocols between players for secondary spectrum trading; system level simulation tool - initial specification”, Deliverable 6.2, Dec. 2011, Version 1.0. [Online]. Available: <http://www.ict-cogeu.eu/deliverables.html> (visited on 10/2015).
- [106] F. J. Gallego, *Mapping rural/urban areas from population density grids*, Ispra, Italy: Institute for Environment and Sustainability, JRC, 2004. [Online]. Available: <http://www.ec-gis.org/docs/F11116/RURAL%5C%20URBAN%5C%20%5C%20POPDENS.PDF> (visited on 10/2015).
- [107] L. Dijkstra and H. Poelman, European Commission, Working Papers 01/2014, May 2014. [Online]. Available: [http://ec.europa.eu/regional\\_policy/en/information/publications/working-papers/2014/a-harmonised-definition-of-cities-and-rural-areas-the-new-degree-of-urbanisation](http://ec.europa.eu/regional_policy/en/information/publications/working-papers/2014/a-harmonised-definition-of-cities-and-rural-areas-the-new-degree-of-urbanisation) (visited on 10/2015).
- [108] E. Dahlman, S. Parkvall, and J. Sköld, *4G: LTE/LTE-Advanced for Mobile Broadband*, 1st ed. Elsevier, Academic Press, 2011, ISBN: 978-0-12-385489-6.
- [109] V. Erceg, L. J. Greenstein, S. Y. Tjandra, S. R. Parkoff, A. Gupta, B. Kulic, A. A. Julius, and R. Bianchi, “An empirically based path loss model for wireless channels in suburban environments”, *IEEE Journal on Selected Areas in Communications*, vol. 17, no. 7, pp. 1205–1211, Jul. 1999, ISSN: 0733-8716. DOI: 10.1109/49.778178.
- [110] V. Erceg *et al.*, IEEE 802.16 Broadband Wireless Access Working Group, IEEE 802.16.3c-01/29r4, Jul. 2001. [Online]. Available: [http://www.ieee802.org/16/tg3/contrib/802163c-01\\_29r4.pdf](http://www.ieee802.org/16/tg3/contrib/802163c-01_29r4.pdf) (visited on 10/2015).
- [111] M. Hata, “Empirical formula for propagation loss in land mobile radio services”, *IEEE Transactions on Vehicular Technology*, vol. 29, no. 3, pp. 317–325, Aug. 1980, ISSN: 0018-9545. DOI: 10.1109/T-VT.1980.23859.
- [112] A. B. Syed, “Dimensioning of LTE network. Description of models and tools, coverage and capacity estimation of 3GPP long term evolution”, Master’s thesis, Helsinki University of Technology, Helsinki, Finland, Feb. 2009.
- [113] P. Vieira, P. Queluz, and A. Rodrigues, “LTE spectral efficiency using spatial multiplexing MIMO for macro-cells”, in *2nd International Conference on Signal Processing and Communication Systems (ICSPCS’08)*, Dec. 2008, pp. 1–6, ISBN: 978-1-4244-4243-0. DOI: 10.1109/ICSPCS.2008.4813660.
- [114] 3GPP, “Evolved universal terrestrial radio access (E-UTRA); base station (BS) radio transmission and reception”, 3rd Generation Partnership Project (3GPP), TS 36.104, Sep. 2012. [Online]. Available: <http://www.3gpp.org/ftp/Specs/html-info/36104.htm> (visited on 04/2014).
- [115] —, “Evolved universal terrestrial radio access (E-UTRA); physical layer procedures”, 3rd Generation Partnership Project (3GPP), TS 36.213, Mar. 2008. [Online]. Available: <http://www.3gpp.org/ftp/specs/html-info/36213.htm> (visited on 04/2014).
- [116] Motorola, *Motorola WBC 700 portfolio*, Jan. 2010.
- [117] D. Dababneh, “LTE traffic generation and evolved packet core (EPC) network planning”, Master’s thesis, Carleton University, Ottawa, Canada, Mar. 2013.

- [118] FUTON, “Architecture, business evaluation and deployment models: Final vision at the end of FUTON”, Deliverable 2.3, Sep. 2010, Version 1.2. [Online]. Available: <http://www.ict-futon.eu/private/docs/deliverables/d2.3.pdf> (visited on 10/2015).
- [119] C. F. Silva and V. S. Ribeiro, “Business evaluation for FUTON-like architectures”, in *IEEE International Conference on Computer as a Tool (EUROCON’11)*, Apr. 2011, pp. 1–4, ISBN: 978-1-4244-7486-8. DOI: 10.1109/EUROCON.2011.5929345.
- [120] M. v. Bredow and G. Reinhart, “Method to evaluate the profitability and risk structure of projects in the automotive industry”, in *IEEE International Conference on Industrial Engineering and Engineering Management (IEEM’09)*, Dec. 2009, pp. 1588–1592, ISBN: 978-1-4244-4869-2. DOI: 10.1109/IEEM.2009.5373105.
- [121] M. Belleschi, G. Fodor, and A. Abrardo, “Performance analysis of a distributed resource allocation scheme for D2D communications”, in *IEEE Global Communications Conference Workshops (GC’11 Wkshps)*, Dec. 2011, pp. 358–362, ISBN: 978-1-4673-0039-1. DOI: 10.1109/GLOCOMW.2011.6162471.
- [122] S. Vasudevan, J. Kurose, and D. Towsley, “On neighbor discovery in wireless networks with directional antennas”, in *24th Annual Joint Conference of the IEEE Computer and Communications Societies (INFOCOM’05)*, vol. 4, Mar. 2005, pp. 2502–2512. DOI: 10.1109/INFCOM.2005.1498535.
- [123] D. Angelosante, E. Biglieri, and M. Lops, “Neighbor discovery in wireless networks: A multiuser-detection approach”, *Physical Communication*, vol. 3, no. 1, pp. 28–36, 2010, ISSN: 1874-4907. DOI: 10.1016/j.phycom.2009.08.005.
- [124] K. Doppler, C. B. Ribeiro, and J. Knecht, “Advances in D2D communications: Energy efficient service and device discovery radio”, in *2nd International Conference on Wireless Communication, Vehicular Technology, Information Theory and Aerospace & Electronic Systems Technology (Wireless VITAE’11)*, Mar. 2011, pp. 1–6, ISBN: 978-1-4577-0787-2. DOI: 10.1109/WIRELESSVITAE.2011.5940857.
- [125] S. Vasudevan, D. Towsley, D. Goeckel, and R. Khalili, “Neighbor discovery in wireless networks and the coupon collector’s problem”, in *Proceedings of the 15th Annual International Conference on Mobile Computing and Networking (MobiCom’09)*, Sep. 2009, pp. 181–192, ISBN: 978-1-60558-702-8. DOI: 10.1145/1614320.1614341.
- [126] L. Zhang and D. Guo, “Neighbor discovery in wireless networks using compressed sensing with Reed-Muller codes”, in *International Symposium on Modeling and Optimization in Mobile, Ad Hoc, and Wireless Networks (WiOpt’11)*, May 2011, pp. 154–160, ISBN: 978-1-61284-824-2. DOI: 10.1109/WIOPT.2011.5930008.
- [127] L. You, Z. Yuan, P. Yang, and G. Chen, “ALOHA-like neighbor discovery in low-duty-cycle wireless sensor networks”, in *IEEE Wireless Communications and Networking Conference (WCNC’11)*, vol. 4, Mar. 2011, pp. 749–754. DOI: 10.1109/WCNC.2011.5779256.
- [128] G. Camarillo, “Peer-to-peer (P2P) architecture: Definition, taxonomies, examples, and applicability”, RFC Editor, RFC 5694, Nov. 2009, pp. 1–26. [Online]. Available: <http://www.rfc-editor.org/rfc/rfc5694.txt>.
- [129] D. Angelosante, E. Biglieri, and M. Lops, “A simple algorithm for neighbor discovery in wireless networks”, in *IEEE International Conference on Acoustics, Speech and Signal Processing (ICASSP’07)*, vol. 3, Apr. 2007, pp. III-169–III-172. DOI: 10.1109/ICASSP.2007.366499.

- [130] Z. Zhang and B. Li, "Neighbor discovery in mobile ad hoc self-configuring networks with directional antennas: Algorithms and comparisons", *IEEE Transactions on Wireless Communications*, vol. 7, no. 5, pp. 1540–1549, May 2008, ISSN: 1536-1276. DOI: 10.1109/TWC.2008.05908.
- [131] E. Felemban, R. Murawski, E. Ekici, S. Park, K. Lee, J. Park, and Z. Hameed, "Sand: Sectorized-antenna neighbor discovery protocol for wireless networks", in *7th Annual IEEE Communications Society Conference on Sensor, Mesh and Ad Hoc Communications and Networks (SECON'10)*, Jun. 2010, pp. 1–9, ISBN: 978-1-4244-7151-5. DOI: 10.1109/SECON.2010.5508291.
- [132] X. An and R. Hekmat, "Self-adaptive neighbor discovery in ad hoc networks with directional antennas", in *16th IST Mobile and Wireless Communications Summit, 2007*, Budapest, Hungary: IEEE, Jul. 2007, pp. 1–5, ISBN: 1-4244-1662-0. DOI: 10.1109/ISTMWC.2007.4299291.
- [133] D. D. Lin and T. J. Lim, "Subspace-based active user identification for a collision-free slotted ad hoc network", *IEEE Transactions on Communications*, vol. 52, no. 4, pp. 612–621, Apr. 2004, ISSN: 0090-6778. DOI: 10.1109/TCOMM.2004.826415.
- [134] L. G. Roberts, "ALOHA packet system with and without slots and capture", *Computer Communications Review*, vol. 5, no. 2, pp. 28–42, Apr. 1975, ISSN: 0146-4833. DOI: 10.1145/1024916.1024920.
- [135] A. P. Subramanian and S. R. Das, "Addressing deafness and hidden terminal problem in directional antenna based wireless multi-hop networks", in *2nd International Conference on Communication System Software and Middleware and Workshops (COMSWARE'07)*, Jan. 2007, ISBN: 1-4244-0614-5. DOI: 10.1109/COMSWA.2007.382626.
- [136] H. Gossain, C. Cordeiro, D. Cavalcanti, and D. P. Agrawal, "The deafness problems and solutions in wireless ad hoc networks using directional antennas", in *IEEE Global Communications Conference Workshops (GC'04 Wkshps)*, Nov. 2004, pp. 108–113. DOI: 10.1109/GLOCOMW.2004.1417558.
- [137] C.-X. Wang, X. Hong, X. Ge, X. Cheng, G. Zhang, and J. Thompson, "Cooperative MIMO channel models: A survey", *IEEE Communications Magazine*, vol. 48, no. 2, pp. 80–87, Feb. 2010, ISSN: 0163-6804. DOI: 10.1109/MCOM.2010.5402668.
- [138] J. L. S. Kneckt, K. F. Doppler, and M. P. O. Rinne, "Method and apparatus for device discovery through beaconing", WO/2011/121374, Jul. 2011. [Online]. Available: <http://patentscope.wipo.int/search/en/W02011121374>.
- [139] T. Deng, R. V. Pragada, G. S. Sternberg, B. Raghathan, Z. Deng, and K. K. Vanganuru, "Method and apparatus for performing neighbor discovery", WO/2012/170794, Dec. 2012. [Online]. Available: <http://patentscope.wipo.int/search/en/W02012170794>.
- [140] J. Hong, S. Park, H. Kim, S. Choi, and K. B. Lee, "Analysis of device-to-device discovery and link setup in LTE networks", in *IEEE 24th Annual International Symposium on Personal, Indoor, and Mobile Radio Communications (PIMRC'13)*, Sep. 2013, pp. 2856–2860. DOI: 10.1109/PIMRC.2013.6666634.
- [141] J. Du, E. Kranakis, and A. Nayak, "Cooperative neighbor discovery protocol for a wireless network using two antenna patterns", in *32nd IEEE International Conference on Distributed Computing Systems Workshops (ICDCSW'12)*, Jun. 2012, pp. 178–186. DOI: 10.1109/ICDCSW.2012.55.

- [142] K. J. Zou, M. Wang, K. W. Yang, J. Zhang, W. Sheng, Q. Chen, and X. You, "Proximity discovery for device-to-device communications over a cellular network", *IEEE Communications Magazine*, vol. 52, no. 6, pp. 98–107, Jun. 2014, ISSN: 0163-6804. DOI: 10.1109/MCOM.2014.6829951.
- [143] Z. Becvar, P. Mach, and M. Vondra, "Optimization of SINR-based neighbor cell list for networks with small cells", in *IEEE 24th Annual International Symposium on Personal, Indoor, and Mobile Radio Communications (PIMRC'13)*, Sep. 2013, pp. 2356–2361. DOI: 10.1109/PIMRC.2013.6666537.
- [144] 3GPP, "Evolved universal terrestrial radio access (E-UTRA); physical channels and modulation", 3rd Generation Partnership Project (3GPP), TS 36.211, Dec. 2009. [Online]. Available: <http://www.3gpp.org/ftp/specs/html-info/36211.htm> (visited on 09/2014).
- [145] S. R. Saunders and A. A. Zavala, *Antennas and Propagation for Wireless Communication Systems*, 2nd ed. John Wiley & Sons, Ltd., 2007, ISBN: 978-0-470-84879-1.
- [146] 3GPP, "Spatial channel model for multiple input multiple output (MIMO) simulations", 3rd Generation Partnership Project (3GPP), TR 25.996, Dec. 2009. [Online]. Available: <http://www.3gpp.org/ftp/specs/html-info/25996.htm> (visited on 04/2014).
- [147] —, "Physical layer aspect for evolved universal terrestrial radio access (UTRA)", 3rd Generation Partnership Project (3GPP), TR 25.814, Sep. 2006. [Online]. Available: <http://www.3gpp.org/ftp/specs/html-info/25814.htm> (visited on 04/2014).
- [148] D. A. Sánchez-Salas, J. L. Cuevas-Ruíz, and M. González-Mendoza, "Wireless channel model with Markov chains using matlab", in *MATLAB - A Fundamental Tool for Scientific Computing and Engineering Applications*, V. N. Katsikis, Ed., vol. 2, InTech, Sep. 2012, pp. 1–28, ISBN: 978-953-51-0751-4. DOI: 10.5772/3338.
- [149] E. Lutz, D. Cygan, M. Dippold, F. Dolainsky, and W. Papke, "The land mobile satellite communication channel-recording, statistics, and channel model", *IEEE Transactions on Vehicular Technology*, vol. 40, no. 2, pp. 375–386, May 1991, ISSN: 0018-9545. DOI: 10.1109/25.289418.
- [150] N. Bhushan, J. Li, D. Malladi, R. Gilmore, D. Brenner, A. Damnjanovic, R. T. Sukhavasi, C. Patel, and S. Geirhofer, "Network densification: The dominant theme for wireless evolution into 5G", *IEEE Communications Magazine*, vol. 52, no. 2, pp. 82–89, Feb. 2014, ISSN: 0163-6804. DOI: 10.1109/MCOM.2014.6736747.
- [151] 3GPP, "Evolved universal terrestrial radio access (E-UTRA); further advancements for E-UTRA physical layer aspects", 3rd Generation Partnership Project (3GPP), TR 36.814, Mar. 2010. [Online]. Available: <http://www.3gpp.org/ftp/Specs/html-info/36814.htm> (visited on 04/2014).
- [152] C. Wengerter, J. Ohlhorst, and A. G. E. von Elbwart, "Fairness and throughput analysis for generalized proportional fair frequency scheduling in OFDMA", in *IEEE 61st Vehicular Technology Conference (VTC 2005-Spring)*, vol. 3, 2005, pp. 1903–1907. DOI: 10.1109/VETECS.2005.1543653.
- [153] J. C. Ikuno, M. Wrulich, and M. Rupp, "System level simulation of LTE networks", in *IEEE 71st Vehicular Technology Conference (VTC 2010-Spring)*, May 2010, pp. 1–5. DOI: 10.1109/VETECS.2010.5494007.

- 
- [154] T. Peng, Q. Lu, H. Wang, S. Xu, and W. Wang, “Interference avoidance mechanisms in the hybrid cellular and device-to-device systems”, in *IEEE 20th Personal, Indoor and Mobile Radio Communications Symposium (PIMRC’09)*, Sep. 2009, pp. 617–621, ISBN: 978-1-4244-5122-7. DOI: [10.1109/PIMRC.2009.5449856](https://doi.org/10.1109/PIMRC.2009.5449856).